



Preface

We appreciate very much for your purchasing of Shihlin servo products. This manual will be a helpful instruction to install, wire, inspect, and operate your Shihlin servo drive and motor.

Before using the servo drive and motor, please read this user manual to prevent from electricshock, fire, and injury.

In this manual, the safety instruction levels are classified into "DANGER" and "CAUTION".

 <b style="font-size: 1.2em;">DANGER	It indicates that incorrect operation may cause hazardous conditions, resulting in death or injury.
 <b style="font-size: 1.2em;">CAUTION	It indicates that incorrect operation may cause hazards, resulting in injury to person or damage to the product.

Note that the CAUTION level may lead to a serious consequence by cases. Be sure to follow the instructions of both levels to keep personnel safety well.

What must not be done and what must be done are indicated by the following marks:

	: It indicates what must not be done.
	: It indicates what must be done.

In this manual, instructions at a lower level than the above, instructions for other functions, and so on are classified into "NOTE".

After reading this user manual , always keep it accessible to the operator.

1. To prevent electric shock, please confirm the following:

 <b style="font-size: 1.2em;">DANGER	<ul style="list-style-type: none"> • Operate the power switches with dry hand to prevent an electric shock. • Before wiring or inspection, switch power off and wait for more than 10 minutes. Then, confirm if the power indicator is off or the voltage is safe with voltage meter. Otherwise, you may get an electric shock. • Connect the servo drive and motor to ground. • Do not attempt to wire the servo drive and motor until they have been installed. Otherwise, you may get an electric shock. • The cables should not be damaged, stressed, loaded, or pinched. Otherwise, you may get an electric shock. • During power-on or operation, do not open the front cover of the servo drive. Otherwise, it may cause an electric shock. • Do not operate the servo drive with the front cover removed. High-voltage terminals and charging area are exposed and you may get an electric shock. • Except for wiring and periodic inspection, do not remove the front cover of the servo drive even if the power is off. The servo deive is charged and you may get an electric shock. • To prevent an electric shock, always connect the protective earth (PE) terminal (marked ⊕) of the servo drive to the protective earth (PE) of the cabinet. • To avoid an electric shock, insulate the connections of the power supply terminals.
---	--

2. To prevent fire, note the following:

 CAUTION
<ul style="list-style-type: none">• Install the servo drive, servo motor, and regenerative resistor on incombustible material. Installing them directly or close to combustibles will lead to smoke or a fire.• When the servo drive failure, please t shuts down the power supply on the side of the servo drive's power supply to avoid continuous flow of a large current which may cause smoke or a fire• When using the regenerative resistor, switch power off with the alarm signal. Otherwise, a regenerative transistor malfunction or the like may overheat the regenerative resistor, causing smoke or a fire.• Provide adequate protection to prevent screws and other conductive matter, oil and other combustible matter from entering the servo drivw and servo motor.• Always connect a molded-case circuit breaker, or a fuse to each servo drive between the power supply and the main circuit power supply of the servo drive.

3. To prevent injury, note the following:

 CAUTION
<ul style="list-style-type: none">• The proper voltage specified in this manual should be applied to each terminal, Otherwise,• a burst, damage, etc. may occur.• Connect the terminals correctly to prevent a burst, damage, etc.• Ensure that polarity (+ , -) is correct. Otherwise, a burst, damage, etc. may occur.• Don't touch the servo drive heat sink, regenerative resistor, servo motor, etc. which may be hot while power is on or for some time after power-off. Otherwise,a injury, damage, etc. may occur.

4. Additional instructions

The following instructions should also be fully noted. Incorrect handling may cause a fault, injury, electric shock, fire, etc.

(1) Transportation and installation

 CAUTION
<ul style="list-style-type: none">• Transport the products correctly according to their mass.• Stacking in excess of the specified number of product packages is not allowed.• Do not hold the motor's cable, shaft and encoder when transporting the servo motor.• Install the servo drive and the servo motor in a load-bearing place in accordance with the manual.• Do not get on or put heavy load on the equipment.• The equipment must be installed in the specified method.• Leave specified clearances between the servo drive and the cabinet walls or other equipment.• Do not install or operate the servo drive and servo motor which have been damaged or have any parts missing.• Do not block the intake and exhaust areas of the servo drive. Otherwise, it may cause a malfunction.• Do not drop or strike the servo drive and servo motor. Isolate them from all impact loads.• Please contact the service department of Shihlin When you want to keep for a long time.

(2) Wiring

 **CAUTION**

- Wire the servo drive correctly and firmly. Otherwise, the motor will run improperly.
- Do not install a power capacitor, surge absorber or noise filter between the servo motor and servo drive.
- To avoid a malfunction, connect the wires to the correct phase terminals (U, V, and W) of the servo drive and servo motor.
- Connect the servo drive power output (U, V, and W) to the servo motor power input (U, V, and W) directly. Do not let a magnetic contactor, etc. intervene. Otherwise, it may cause a malfunction.
- The surge absorbing diode installed to the DC relay for control output should be fitted in the specified direction. Otherwise, the emergency stop and other protective circuits may not operate.
- When the cable is not tightened enough to the terminal block, the cable or terminal block may generate heat because of the poor contact. Be sure to tighten the cable with specified torque.

(3) Test run and adjustment

 **CAUTION**

- Before operation, check the parameter settings. Improper settings may cause some machines to perform unexpected operation.
- Never adjust or change the parameter values extremely as it will make operation unstable.

(4) Usage

 **CAUTION**

- Provide an external emergency stop circuit to ensure that operation can be stopped and power switched off immediately.
- Do not disassemble, repair, or modify the equipment.
- Before resetting an alarm, make sure that the run signal of the servo drive is off in order to prevent a sudden restart. Otherwise, it may cause an accident.
- Use a noise filter, etc. to minimize the influence of electromagnetic interference. Electromagnetic interference may be given to the electronic equipment used near the servo drive.
- Burning or breaking a servo drive may cause a toxic gas. Do not burn or break it.
- Use the servo drive with the specified servo motor.
- The electromagnetic brake on the servo motor is designed to hold the motor shaft and should not be used for ordinary braking.

(5) Maintenance and inspection

 **CAUTION**

- Ensure that the power indicator is off before maintenance or inspection performed.
- Only personnel who have been trained should conduct maintenance and inspection.
- Do not try to disassemble the servo drive or motor which any fault occurred.
- As power is still applied, not to connect or break the UVW wire of servo drive and servo motor to prevent electrical shock.
- The electromagnetic brake on the servo motor is designed to hold the motor shaft and should not be used for ordinary braking.

NOTE : This manual may be revised without prior notice. Please consult our agent or download the most updated version at <http://www.seec.com.tw/en/> .

Index

1. Production inspection and model descriptions	1
1.1 Summary	1
1.2 Inspection	1
1.3 Servo drive appearance and panel descriptions	3
1.4 Overview of servo drive operation modes	5
1.5 Recommended specifications for circuit breaker and fuse	5
2. Installation	6
2.1 Cautions and storage methods	6
2.2 The environment conditions of installation	6
2.3 Installation direction and space	6
3. Wiring and signals	8
3.1 Connections between main power source and peripheral devices	8
3.1.1 Wiring diagram of peripheral devices(below 1KW)	8
3.1.2 Wiring diagram of peripheral devices(1.5KW~3KW)	9
3.1.3 Wiring diagram of peripheral devices(above 5KW)	10
3.1.4 Descriptions for drive's connectors and terminals	11
3.1.5 Wiring method of power source	11
3.1.6 Lead wire connector specifications of motor U,V,W terminals	12
3.1.7 Selection of wiring materials	13
3.2 Functional block diagram of Shihlin servo	14
3.3 CN1 I/O signal wires instruction	17
3.3.1 CN1 terminal layout	17
3.3.2 Signal description of CN1 terminal	19
3.3.3 Interface wiring diagram	28
3.3.4 User definition of DI/DO	32
3.4 CN2 Encoder signal wiring and description	33
3.4.1 Encoder signal wiring and description	33
3.5 CN2L Encoder	34
3.6 CN3 communication port signal wiring and description	35
3.7 CN4 USB communication port	35
3.8 Standard wiring method	35
3.8.1 Wiring diagram of position control(Pr Mode)	36
3.8.2 Wiring diagram of position control(Pt Mode)	37
3.8.3 Wiring diagram of speed control(S Mode)	38
3.8.4 Wiring diagram of torque control(T Mode)	39
3.8.5 Wiring diagram with 1PG	40
3.8.6 Wiring diagram with 10PG	41
3.8.7 Wiring diagram with 10GM	42
3.8.8 Wiring diagram with 20GM	43

3.8.9 Wiring diagram with FX3U	44
3.8.10 Wiring diagram with QD75	45
3.8.11 Wiring diagram with Gantry	46
4. Panel display and operation	47
4.1 Panel components	47
4.2 Display flowchart	47
4.3 Status display	48
4.4 Alarm display	51
4.5 Diagnostic display	52
4.5.1 Indication of external I/O signals	52
4.5.2 DO forced output	53
4.5.3 JOG test	54
4.5.4 Positioning test	55
4.5.5 Automatic offset of analog command input	56
4.5.6 Inertia estimation	57
4.6 Parameter display	57
4.6.1 16bit parameter setting method	57
4.6.2 32bit parameter setting method	58
5. Operation	62
5.1 Checklist before operation	62
5.2 Idle operation	62
5.2.1 Idle JOG test	62
5.2.2 Idle positioning test	63
5.3 Tuning process	64
5.3.1 Abstract	64
5.3.2 Auto-gain tuning mode	65
5.3.3 Manual gain tuning mode	68
5.4 Parameter setting and operation for position control mode	70
5.5 Parameter setting and operation for speed control mode	71
5.6 Parameter setting and operation for torque control mode	72
6. Control function	73
6.1 Control mode option	73
6.2 Torque control mode	73
6.2.1 Output proportion of maximum torque analog command	73
6.2.2 Torque analog command offset	74
6.2.3 Torque analog command smoothing	74
6.2.4 Torque limit of torque control mode	75
6.2.5 Speed limit of torque control mode	75
6.3 Speed control mode	76
6.3.1 Selection of speed command	76

6.3.2	Output speed of maximum speed analog command	77
6.3.3	Speed analog command smoothing	77
6.3.4	Torque limit of speed control mode	79
6.3.5	Adjustment of speed loop gain	80
6.3.6	Resonance suppression filter	81
6.3.7	Gain switch function	84
6.4	Position control mode	86
6.4.1	External pulse-train command(Pt mode)	87
6.4.2	Inner register command(Pr mode)	88
6.4.3	Position command smoothing	89
6.4.4	Electronic gear ratio	90
6.4.5	Torque limit of position control mode	91
6.4.6	Position loop gain	91
6.5	Hybrid control mode	92
6.5.1	Position/speed hybrid mode	93
6.5.2	Speed/torque hybrid mode	93
6.5.3	Torque/Position hybrid mode	94
6.6	Other functions	95
6.6.1	Selection of brake resistor	95
6.6.2	Analog monitor output	97
6.6.3	Operation of electromagnetic brake interlock	98
7.	PR (Procedure) Procedure control function description	100
7.1	Pr mode description	100
7.2	The difference of PR mode between SDH and SDA	100
7.3	DI/DO and timing of PR mode	100
7.4	Parameter setting of PR mode	101
7.5	The status of procedure connection	106
8.	Parameters	109
8.1	Parameter definition	109
8.2	Parameter list	110
8.3	Parameter details list	121
9.	Communication functions	152
9.1.	Communication interface and wiring	152
9.2	Relevant parameters of communication	154
9.3	Modbus protoco	154
A.	ASCII mode	154
B.	RTU mode	157
9.4.	Communication parameter write-in and read-out	161
10.	Inspection and Maintenance	166

10.1 Basic Inspection -----	166
10.2 Maintenance -----	166
10.3 Life of consumable components -----	166
11. Troubleshooting -----	167
11.1. Alarm list -----	167
11.2. Alarm cause and remedy -----	169
12. Specifications -----	178
12.1 Specifications of servo drives -----	178
12.2 Dimensions of servo drives -----	180
12.3 Specifications of low inertia motors SMH-L□□□R30□□□ series -----	182
12.4 Specifications of medium inertia motors SMH-M□□□R20□□□series -----	183
12.5 Dimensions of low inertia motor -----	184
12.6 Permissible shaft load of low inertia motor -----	185
12.7 Dimensions of medium inertia motors -----	185
12.8 Permissible shaft load of medium inertia motor -----	190
12.9 Precision of motor shaft -----	190
12.10 Electromagnetic compatible filter (EMC Filter) -----	190
12.11 Power Factor Improving DC Reactor -----	191
13. Motor characteristic -----	192
13.1 Speed-torque curves of low inertia motor -----	192
13.2 Speed-torque curves of medium inertia motor -----	192
13.3 Overload protection -----	193
14. Absolute servo system -----	195
14.1 Mitsubishi Absolute Position Detection System -----	197
14.1.1 Signal explanation -----	197
14.1.2 Startup procedure -----	197
14.1.3 Absolute position data transfer protocol -----	198
14.2 Delta Absolute Position Detection System -----	205
14.2.1 Signal explanation -----	205
14.2.2 Start procedure -----	205
14.2.3 Use Digital Inputs/Outputs to Initialize an Absolute System -----	206
14.2.4 Use Parameters to Initialize an Absolute System -----	206
14.2.5 Absolute position data communication protoco -----	207
Appendix A Accessories -----	209
Appendix B Parameters communication address -----	216
Appendix C Version information -----	218

1. Production inspection and model descriptions

1.1 Summary

The control modes for Shihlin multi-purpose AC servo could be classified into the single mode and hybrid mode. There are 4 control types for single mode: position control with terminals input, position control with inner registers, speed control, torque control. There are 5 types for hybrid mode: position control (terminals input)/speed control, position control (terminals input)/torque control, position control (inner registers)/speed control, position control (inner registers)/torque control and speed control/torque control.

Therefore, Shihlin servo is suitable for the general industry machinery that requires the high precision and smooth speed control, or machine tools, or tension control.

Shihlin servo is not only equipped with RS-232/RS-485 serial communication but also the most convenient equipment "USB" which is the most popular application. The PC with Shihlin communication software would help the user to adjust the parameters, to operate the servo for test and to monitor the status of the drive.

Shihlin servo is also equipped with the automatic tuning function. The control gain of the drive would be adjusted by the inner algorithm. The specification of Shihlin servo encoder is the 22-bit pulse/rev. It offers a high precision control.

1.2 Inspection

Please check the following items carefully to prevent the negligence of transport or human factors :

- Check if there are any loosened screws on the motor or the drive.
- Check the specification nameplate of motor/drive to confirm the consistency of your demand. Models can be found on the listed in the following table section.
- Check if there are any scratch and damage on the motor/drive.
- Manually turn the shaft of servo motor. A smooth turn indicates a normal motor. If the motor is with an electromagnetic brake, the motor will not be turned easily by hand.

Please contact your agent for solutions if any of above issues occurs.

A complete set of Shihlin servo should include:

1. A servo drive and a servo motor
2. One UVW motor power cable, one end is for plugging onto the drive, the other end onto the motor, with the green cable for grounding (Optional)
3. An encoder signal cable. One end is for the CN2 of drive, the other end for servo motor.
4. The RS232 cable. One end is for the CN3 of drive, the other end for USB PORT of PC. (Option)
5. The USB cable. One end is for the CN4 of drive, the other end for USB PORT of PC. (Option)
6. A 50- PIN connector of CN1.
7. The 5-pin (R/S/T/L1/L2) quick plug-in terminal which is applicable to 1KW drive or below.
8. The 3-pin (P/D/C) quick plug-in terminal which is applicable to 1KW drive or below.
9. The 5-pin (P/N/R/S/T) quick plug-in terminal which is applicable to 1.5KW drive or above.
10. The 5-pin (P/D/C/L1/L2) quick plug-in terminal which is applicable to 1.5KW drive or above.
11. The 3-pin (U/V/W) quick plug-in terminal.
12. An installation manual.
13. A user manual of Shihlin servo. (It could be downloaded from Shihlin website)

Reference for product type

Coding rule for Shihlin servo motor.

Coding method

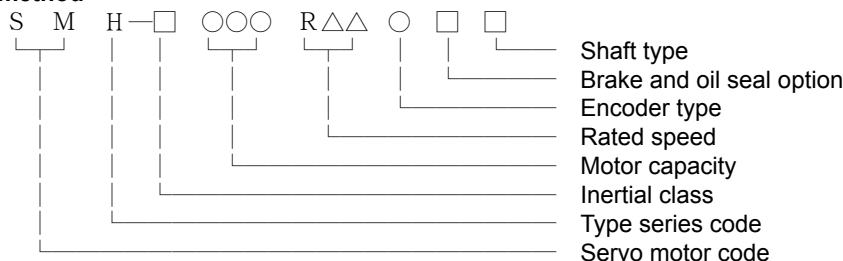

Description for coded items

1. Servo motor code: SM denotes servo motor.
2. Type series code: H series.
3. Inertia class: Code is classified by motor inertia and frame size as follows.

Code	Class
L	Low inertia
M	Medium inertia

4. Motor capacity: The motor output power. The first 2 digits are used to represent the motor's output multiplied by 1/10 and a default unit "KW". If the third digit is a "K", the capacity is the first 2 digits multiplied by 1KW. Here are some examples.
 020 denotes: $02 * (1/10) = 0.2KW = 200W$
 150 denotes: $15 * (1/10) = 1.5KW = 1500W$
 350 denotes: $35 * (1/10) = 3.5KW = 3500W$...and so on
5. Rated speed: **Rated speed of servo motor. It is denoted by 3 digits. First digit is represented by R, second 2 digits is represented by 20(2000rpm) or 30(3000rpm).**
 R20 represents the rated speed is 2000rpm.
 R30 represents the rated speed is 3000rpm.
6. Encode type: the type of Shihlin motor
 S represents a transition type (22bit)
 M represents the multi-back transition type (22bit/16bit)
7. Brake and oil seal: Motors with/without brake or oil seal are presented below.

Code	Item	A	B	C	D
	Brake	Without	With	Without	With
	Oil seal	Without	Without	With	With

8. Shaft type: It describes the shape of the motor shaft. K denotes the inclusion of a keyway.

Coding example

Example 1: If a 200W low inertia motor, 3000rpm rated speed, no brake, no oil seal, no keyway and a transition type, its name code should be: SMH-L020R30SA

Example 2: If a 1500W medium inertia motor, 2000rpm, with brake, no oil seal, with keyway and the multi-back transition type, its name code should be: SMH-M150R20MBK

Coding rule for Shihlin servo drive:

Coding method

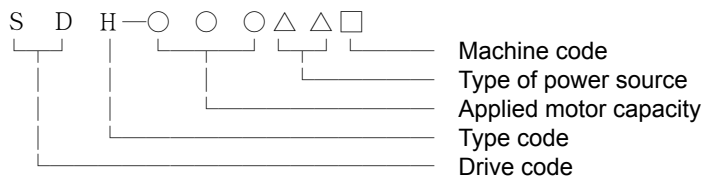

(2) Description for coded items

Drive code: SD denotes "servo drive".

Type code: H series.

Applied motor capacity: There are 3 digits to present the capacity of servo drive. The first 2 digits are used to present the drive's output multiplied by 1/10. If the third digit is a "K", the capacity is the first 2 digits multiplied by 1KW. Here are some coding examples.

020 denotes: $02 * (1/10) = 0.2KW = 200W$

150 denotes: $15 * (1/10) = 1.5KW = 1500$

350 denotes: $35 * (1/10) = 3.5KW = 3500W$...and so no.

Type of power source: Specification of input power.

A2: denotes the applied power is 220V

Machine code:

A: Open-loop

C: Closed-loop

(3) Coding example

Example:

If a 200W drive applied a 3-phase 220V power source and Open loop, its name code should be: SDH-202A2A

1.3 Servo drive appearance and panel description

1.3.1. Servo drive appearance and panel description Below 3.5KW

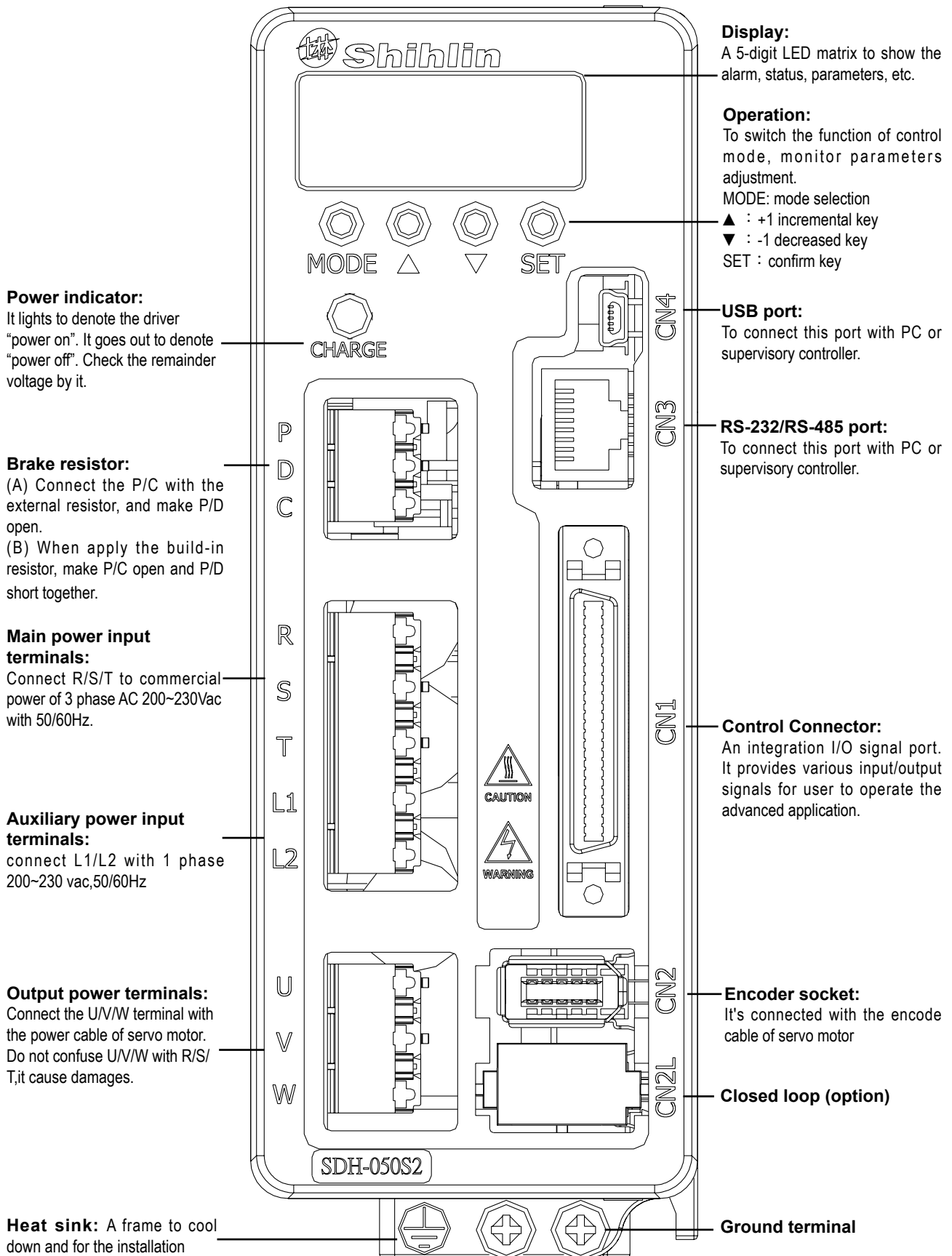

1.3.2. Servo drive appearance and panel description above 5KW

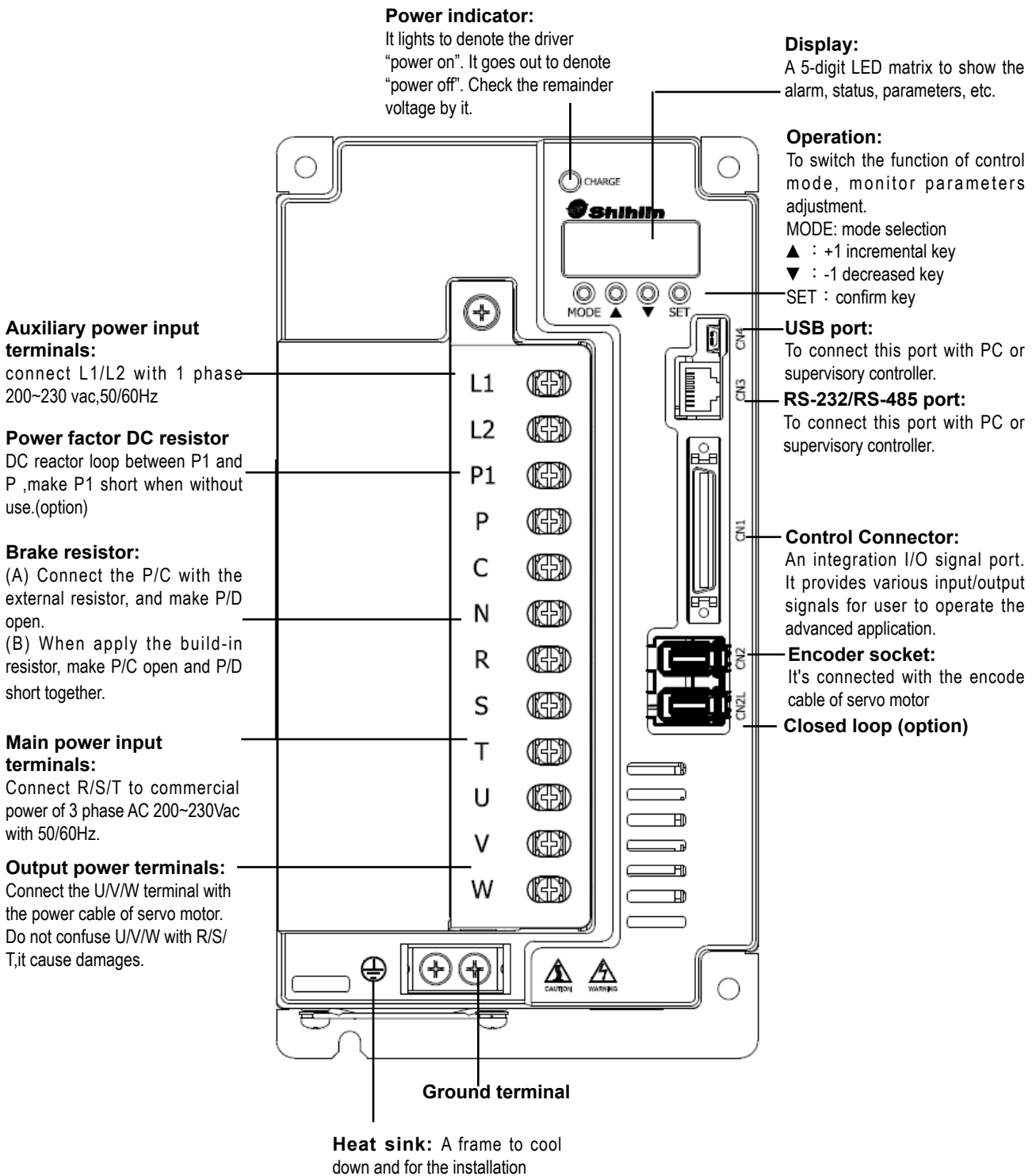

1.4 Overview of servo drive operation modes

Shihlin Servo Drives provide multiple operation modes for users to select.

Mode		Sign	Description
Single mode	Position control (terminal input)	Pt	Drive runs motor to reach the goal according to the external commands which are received through the CN1 and are in the form of pulse trains.
	Position control (inner register)	Pr	Drive runs motor to reach the goal according to the inner commands which are from inner 64 registers that could be switched by DI signals.
	Speed control	S	Drive runs motor to attain the target speed. The command type which is an analog voltage or the inner 7 registers could be switched by DI.
	Torque control	T	The drive receives the commands to run the motor to generate the demanded torque. The command source is the analog voltage.
Hybrid mode		Pt-S	Pt/S is switched mutually via the LOP signal of DI.
		Pt-T	Pt/T is switched mutually via the LOP signal of DI.
		Pr-S	Pr/S is switched mutually via the LOP signal of DI.
		Pr-T	Pr/T is switched mutually via the LOP signal of DI.
		S-T	S/T is switched mutually via the LOP signal of DI.

- ◆ Modify the PA01 value to define the application of mode switch. The PA01 modification works after the “Power on” restart.
- ◆ If the default value of PA01 is applied set the PA01 value as “1□□□”.

1.5 Recommended specifications for circuit breaker and fuse

Specification of circuit breaker and fuse are applicable to Shihlin Servo drives.

Drive type	Fuse capacity	Circuit breaker capacity
SDH-010A2	5A	5A
SDH-020A2	5A	5A
SDH-040A2	20A	10A
SDH-050A2	20A	10A
SDH-075A2	20A	10A
SDH-100A2	25A	15A
SDH-150A2	40A	20A
SDH-200A2	60A	30A
SDH-350A2	80A	30A
SDH-500A2	125A	50A
SDH-700A2	150A	100A

2. Installation

2.1 Caution and storage methods

- Do not install the products on the inflammable matters or close to the inflammable matters.
- Do not over tighten the wire between the drive and the motor.
- Do not place heavy objects on the top of the drive.
- Be sure to tight lock every screw when fixed the drive.
- Install the drive at a location where could bear the weight of the drive.
- Align the axle of the motor and the axle of the machinery device.
- Inflammable objects or conductive objects are not allowed inside the drive.
- Upgrade the diameter of the U/V/W wires and the encoder cable if the length between the drive and the motor is over 20m.
- Do not clog up the vent of the drive or breakdown may be occurred.
- Do not drop or clash the drive.
- Not try to run the drive which something has been damaged.
- Please refer to section 10.1 and 10.3 for drive and motor storage details.

2.2 The environment conditions of installation

The ambient temperature suitable for Shihlin drive is between 0°C and 55°C . If the ambient temperature is higher than 45 °C , the installation place with good ventilation or air conditioner is necessary. For a long-time operation, place the drive in an environment with temperature below 45 °C to ensure the reliability of the drive. If the product is installed in a distributor, make sure that its size and ventilation condition. To prevent from over-heat of the electronic components inside it. Make sure that mechanical vibration will not affect the electronic devices of the distributor. In addition, the use of Shihlin servo shall meet the following criteria:

- Locations with high-heating devices.
- Locations without floating dust and metal particles.
- Locations without corrosive, inflammable gas and liquid.
- Locations without water drops, steam, dust or oil dust
- Locations without electromagnetic interference.
- Select a solid, vibration-free location.

2.3 Installation direction and space

Attention:

Follow the instruction of installation direction avoid the breakdown of drive. To provide a good ventilation by keeping sufficient space between the drive and other objects to avoid breakdown. Do not seal the vent of the drive or make the drive upside down during the installation to avoid breakdown.

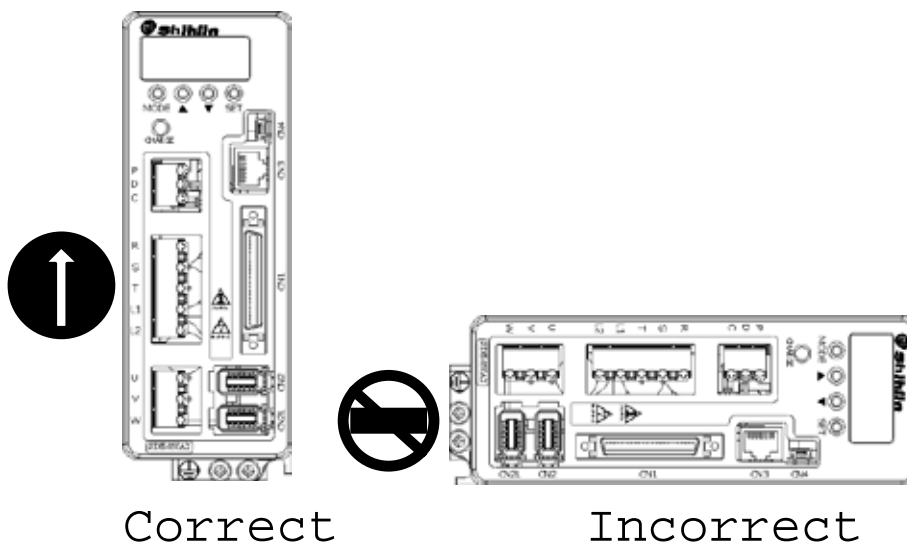

Installation diagram:

To achieve a lower wind resistance of the heat-dissipation fan for a more effective heat removal, follow the spacing recommendation for installing one or multiple AD drive Servo Drive. See the figure below.

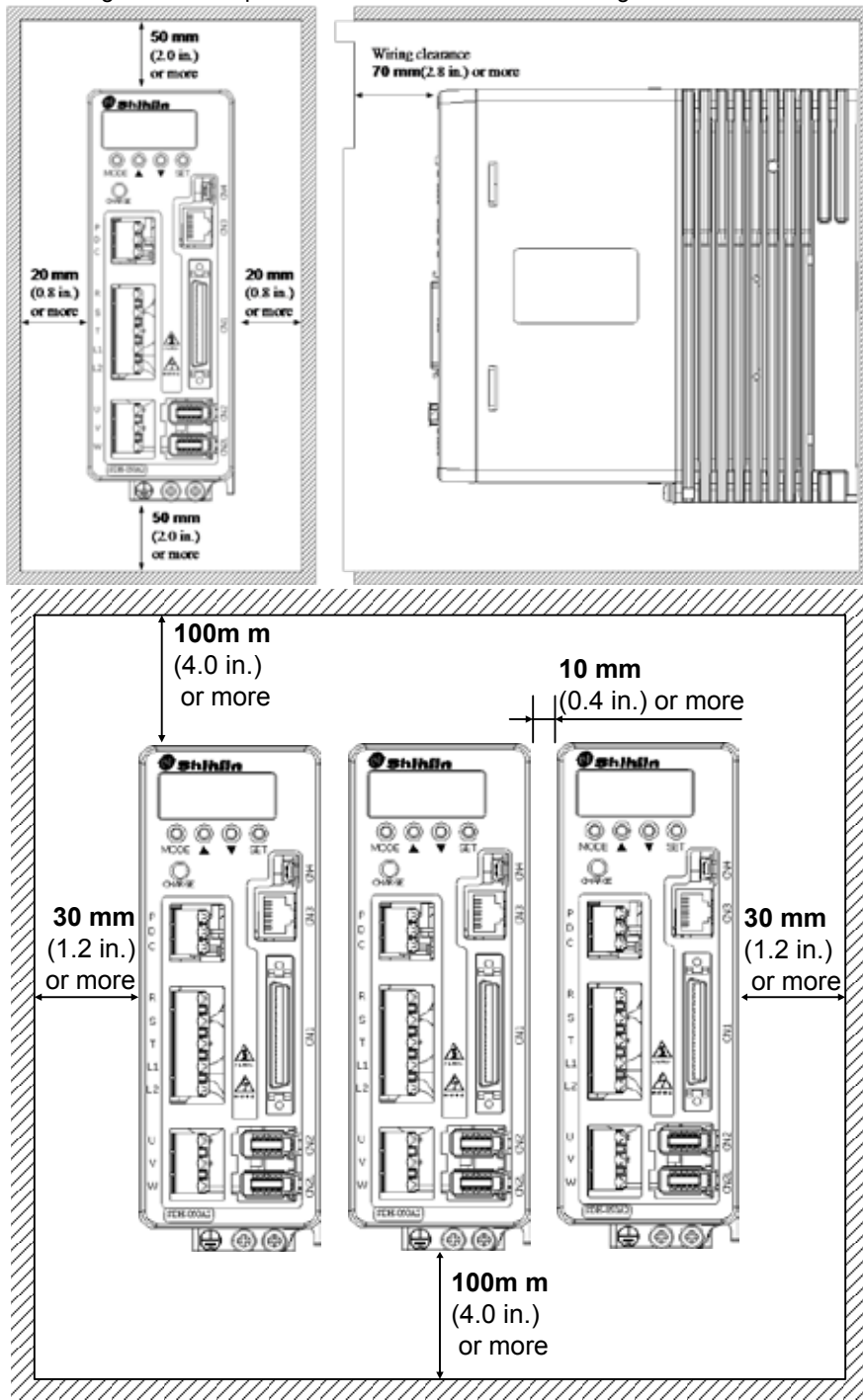

3. Wiring and signals

This chapter defines the wiring diagrams for operation and the signals of Shihlin servo drive.

3.1 Connections between main power source and peripheral devices

3.1.1. Wiring diagram of peripheral devices-Below 1KW

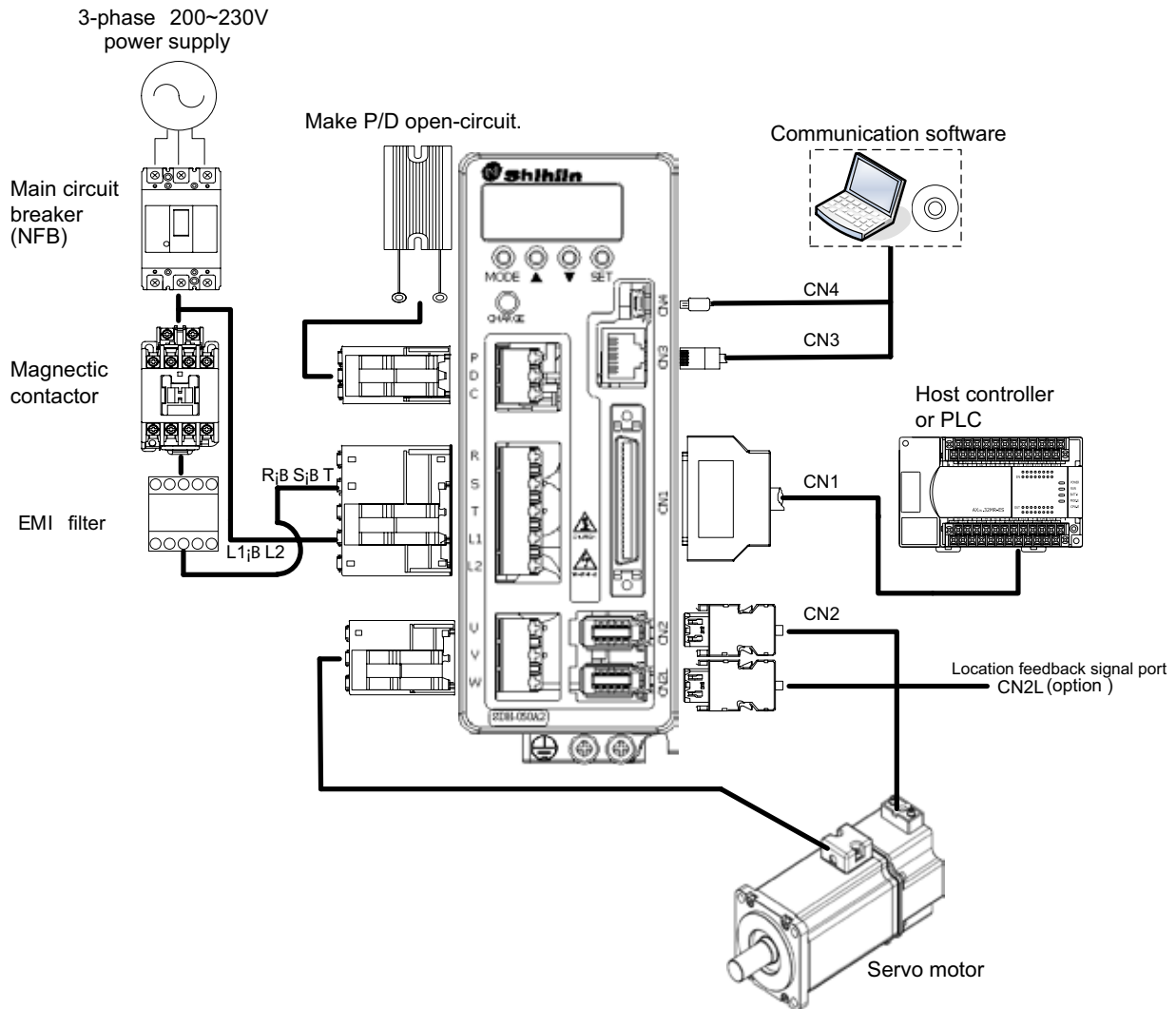

※ The details of EMI filter, please refer to Section 12.10(EMI Filter)

⚠ DANGER To prevent electric shock, be sure to protect the servo drive ground (PE) terminal (⊕ terminal tagged) connected to the protective earthing protection cabinet (PE) on.

3.1.2 Wiring diagram of peripheral devices-above 1.5KW~3KW

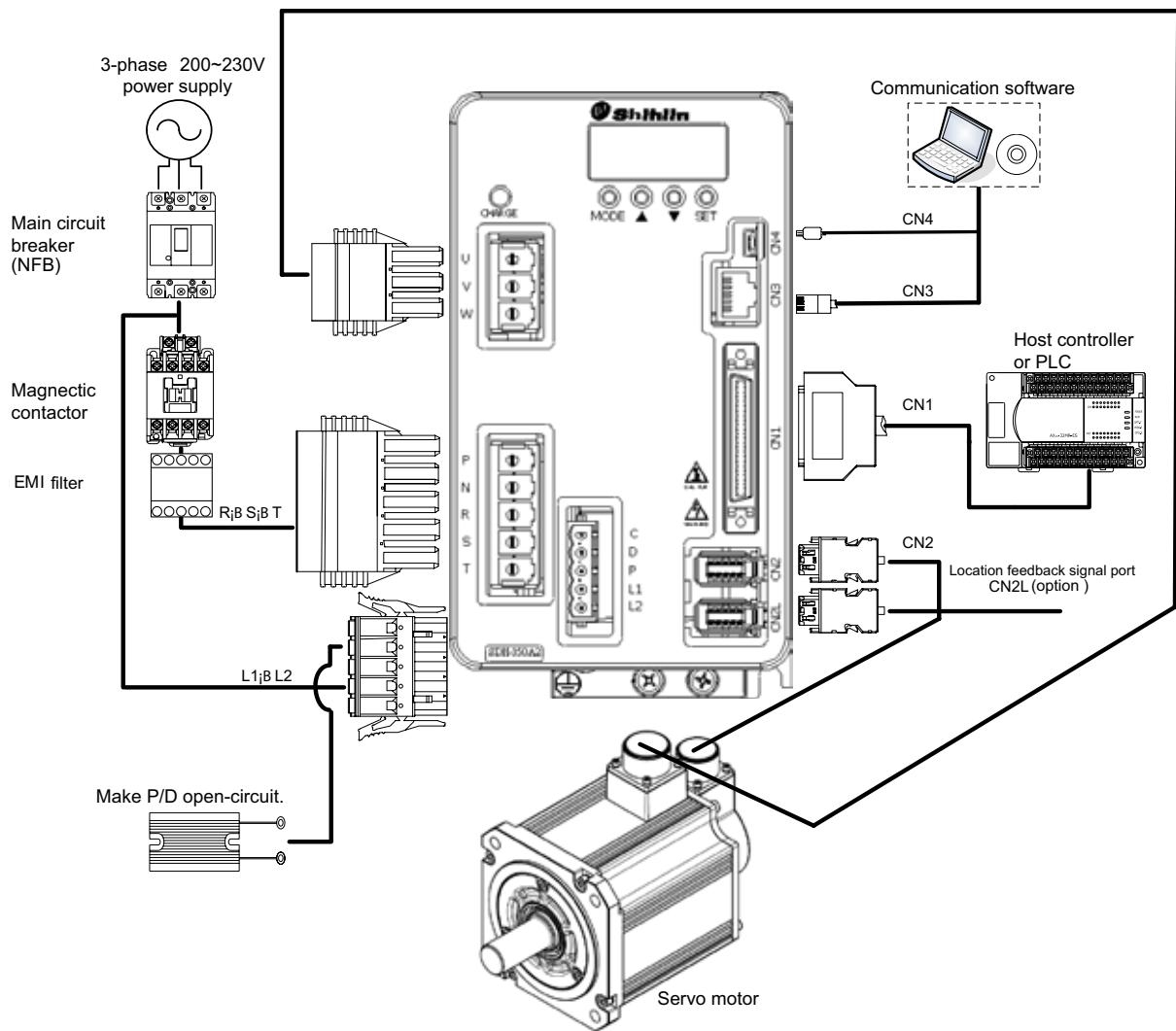

※ The details of EMI filter, please refer to Section 12.10 (EMI Filter)

⚠ DANGER To prevent electric shock, be sure to protect the servo drive ground (PE) terminal (⊕ terminal tagged) connected to the protective earthing protection cabinet (PE) on.

3.1.3 Wiring diagram of peripheral devices-above 5KW

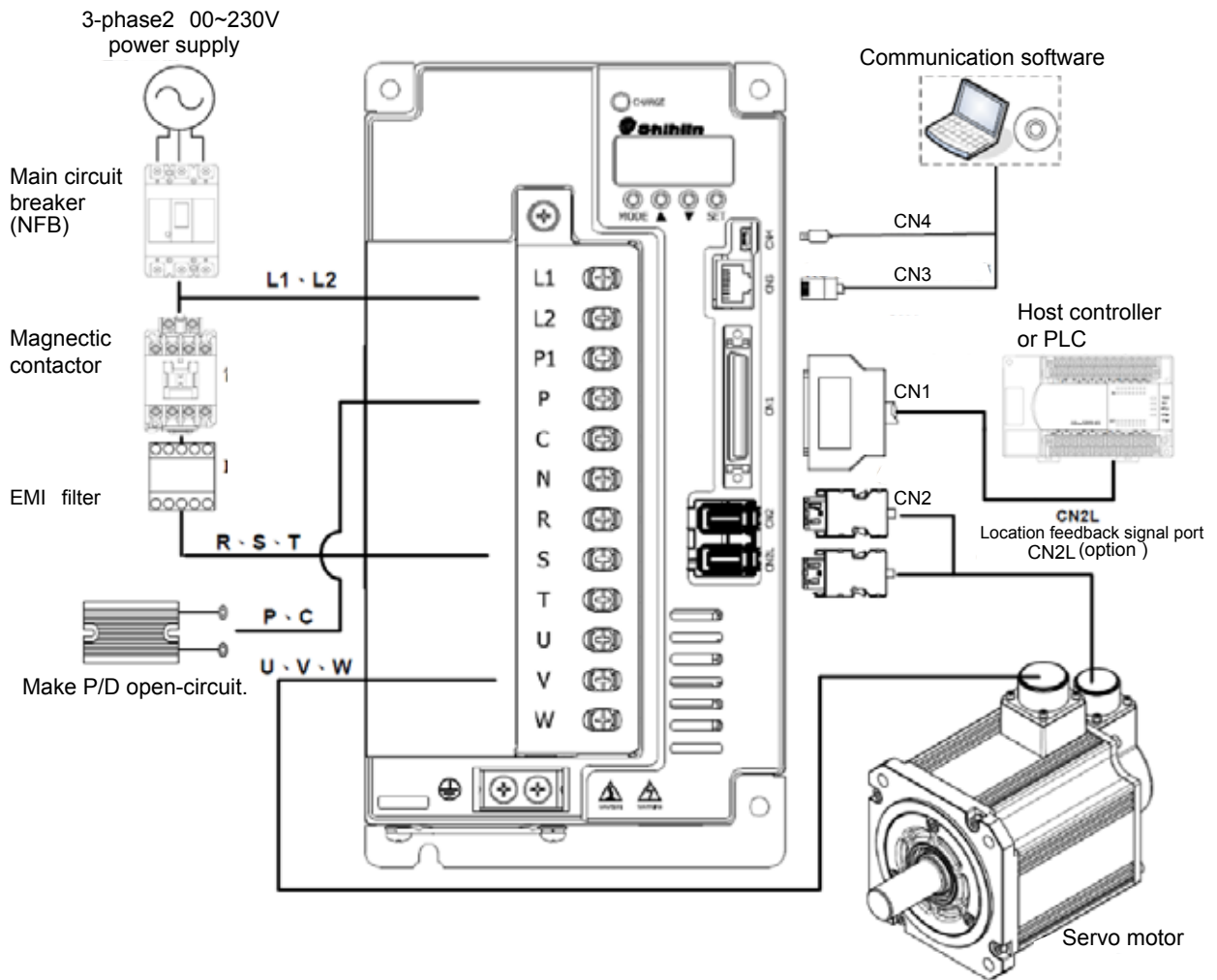

※ The details of EMI filter, please refer to Section 12.10 (EMI Filter)

DANGER To prevent electric shock, be sure to protect the servo drive ground (PE) terminal (⊕ terminal tagged) connected to the protective earthing protection cabinet (PE) on.

NOTE Installation instruction :

- Make sure the servo motor output terminals U/V/W are wired correctly.
- When external brake resistor is used, make P/D ends open and connect the P/C ends to the external brake resistor. If the built-in one applied, make P/D ends short and P/C ends open. Be sure that the brake resistor is connected with the drive in operation.
- Do not confuse R/S/T with L1/L2 or it causes the damage of servo.

3.1.4 Descriptions of drive's connectors and terminal

Name	Code	Description										
Main power input terminal	R · S · T	Connect to 3-phase AC power source										
Control power input terminal	L1 · L2	Connect to single phase AC power source										
Power output terminal for motor	U · V · W · PE	<table border="1"> <thead> <tr> <th>Terminal code</th> <th>Wire color</th> </tr> </thead> <tbody> <tr> <td>U</td> <td>Red</td> </tr> <tr> <td>V</td> <td>White</td> </tr> <tr> <td>W</td> <td>Black</td> </tr> <tr> <td>PE</td> <td>Green</td> </tr> </tbody> </table>	Terminal code	Wire color	U	Red	V	White	W	Black	PE	Green
		Terminal code	Wire color									
		U	Red									
		V	White									
		W	Black									
PE	Green											
Brake resistor terminal	P · D · C	External resistor P/C ends connected to resistor and P/D end open.										
		Built-in resistor P/D ends short together and P/C ends open										
Ground terminal	⊕	To connect the power ground with the motor ground.										
P : main circuit (+)terminal N : main circuit(-)terminal	P · N	When an active brake device is used for 1.5KW or above, please connect the (+) terminal of it to the drive's (P) terminal, the (-) terminal to the drive's (N) terminal. The active brake device is usually applied when the huge regenerative power produced by the servo motor in heavy duty.										
DC reactors	P · P1	AC current loop between P and P1. Please make it short without use this port.(This terminal is only for the type under 5kw)										
I/O Connector	CN1	Connect to the host controller										
Encoder socket	CN2	Connect to the encoder cable of servo motor										
Location feedback signal port	CN2L	Connect to encoder or close loop										
RS-232/RS-485 port	CN3	Connect to the COM PORT of PC.										
USB port	CN4	Connect to the USB port of PC.										

Confirm the items as follows when wiring:

- Keep the major power lines R/ST and U/V/W away from other signal lines at least 30cm.
- Do not touch the major power lines until the charge indicator goes out. When "power off", there is still a large amount of electric charge in the aluminum capacitors inside the servo drive.
- If a longer encoder cable is required, uses the twisted pairs cable and not to exceed 20m. Be sure to upgrade the diameter of wires to avoid signals attenuated when the wire's length greater than 20m.

⚠ DANGER Please insulate the connecting part of the power terminal to avoid electric shock.

⚠ WARNING Make sure the servo and motor output terminals U/V/W are wired correctly. Otherwise it may cause shock.
Make sure the servo motor output terminals is wired correctly.

3.1.5 Wiring method of power source

Shihlin servo drive is connected to a three-phase power source. In the figure below, Power ON is contact a and alarm processing is contact b. 1MC/a is the self-maintained power source, and 1MC is the electromagnetic contactor.

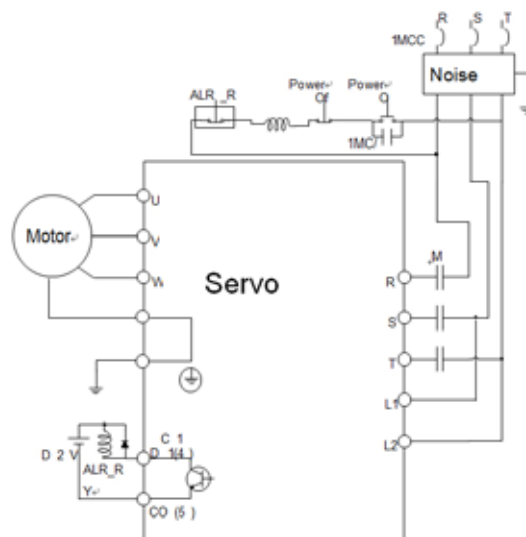

Note: The terminals P/N of servo drive 1.5KW above could not be connected to ground.

3.1.6 Lead wire connector specifications of motor U/V/W terminals

Connector specifications (female type) of U/V/W terminals of the low inertia Shihlin servo motor:

Drive capacity	Motor type	
100W	SMH-L010R30S□□	<p>With brake without brake</p>
200W	SMH-L020R30S□□	
400W	SMH-L040R30S□□	
750W	SMH-L075R30S□□	

The lead wire signs of low inertia motor, U/V/W terminal connector are listed as follows:

PIN	Sign	Wire color
1	U	Red
2	V	White
3	W	Black
4	PE	Green(background)/Yellow
5	NC	Black (with electromagnetic brake)
6	NC	Black (with electromagnetic brake)

Note: The aforesaid wires are connected to the connectors of the motor.

Connector specifications (male type) of U/V/W terminals of the medium inertia servo motor:

Drive capacity	Motor type	
500W	SMH-M050R20□□□	
1KW	SMH-M100R20□□□	
1.5KW	SMH-M150R20□□□	
2KW	SMH-M200R20□□□	
3.5KW	SMH-M350R20□□□	

The lead wire signs of medium inertia motor under 3.5KW, U/V/W terminal connector are listed as follows:

PIN	Sign
A	NC
B	U
C	V
D	W
E	PE
F	NC (with electromagnetic brake)
G	NC (with electromagnetic brake)
H	NC

Note: The aforesaid wire are connected to the connectors of the motor

Drive capacity	Motor type	
5KW	SMH-M500R20□□□	
7KW	SMH-M700R20□□□	
5KW brake connctor	SMH-M500R20□□□	
7KW brake connctor	SMH-M700R20□□□	

The lead wire signs of medium inertia motor above 5KW, U/V/W terminal connector are listed as follows:

PIN	Sign
A	U
B	V
C	W
D	Grounded

The lead wire signs of medium inertia motor above 5KW, brake connector are listed as follows:

PIN	Sign
A	NC
B	NC

Note: The detail wiring of brake connector please refer to section 6.6.3

3.1.7 Selection of wiring materials

Please follow the following recommendations and the use the proper specification.

Drive type	Cable(mm ²)				
	Specification for power wiring (AWG)				
	R · S · T	L1 · L2	U · V · W	P · D · C	B1 · B2
SDH-010A2	2(AWG14)	1.25(AWG12)	1.25(AWG16)	2(AWG14)	1.25(AWG16)
SDH-020A2					
SDH-040A2					
SDH-050A2					
SDH-075A2					
SDH-100A2			2(AWG14)		
SDH-150A2			3.5(AWG12)		
SDH-200A2	3.5(AWG12)	5.5(AWG10)			
SDH-350A2	5.5(AWG10)	5.5(AWG10)			
SDH-500A2	5.5(AWG10)	5.5(AWG10)			
SDH-700A2	8(AWG8)	8(AWG8)	3.5(AWG12)		

Drive type	Specification for encoder wiring (AWG)			
	Sire gauge	Length	Core number	Core gauge
SDH-010A2	UL1332	2m	10	AWG26
SDH-020A2	UL1332	2m	10	AWG26
SDH-040A2	UL1332	2m	10	AWG26
SDH-050A2	UL1332	2m	10	AWG26
SDH-075A2	UL1332	2m	10	AWG26
SDH-100A2	UL1332	2m	10	AWG26
SDH-150A2	UL1332	2m	10	AWG26
SDH-200A2	UL1332	2m	10	AWG26
SDH-350A2	UL1332	2m	10	AWG26
SDH-500A2	UL1332	2m	10	AWG26
SDH-700A2	UL1332	2m	10	AWG26

- Please follow the recommended list above or a larger specification to complete the wiring job.
- The SHIELD terminal of the shield cable has to be connected to the power ground.
- Use a shield twisted pair cable for the wiring of encoder to reduce noise interference.
- American Wire Gauge (AWG) is the standard wire diameter gauge of America.

3.2 Functional block diagram of Shihlin servo

100W~1kW:

Shihlin servo driver

Capacity: 100W~1KW
Power source: 200V~230V

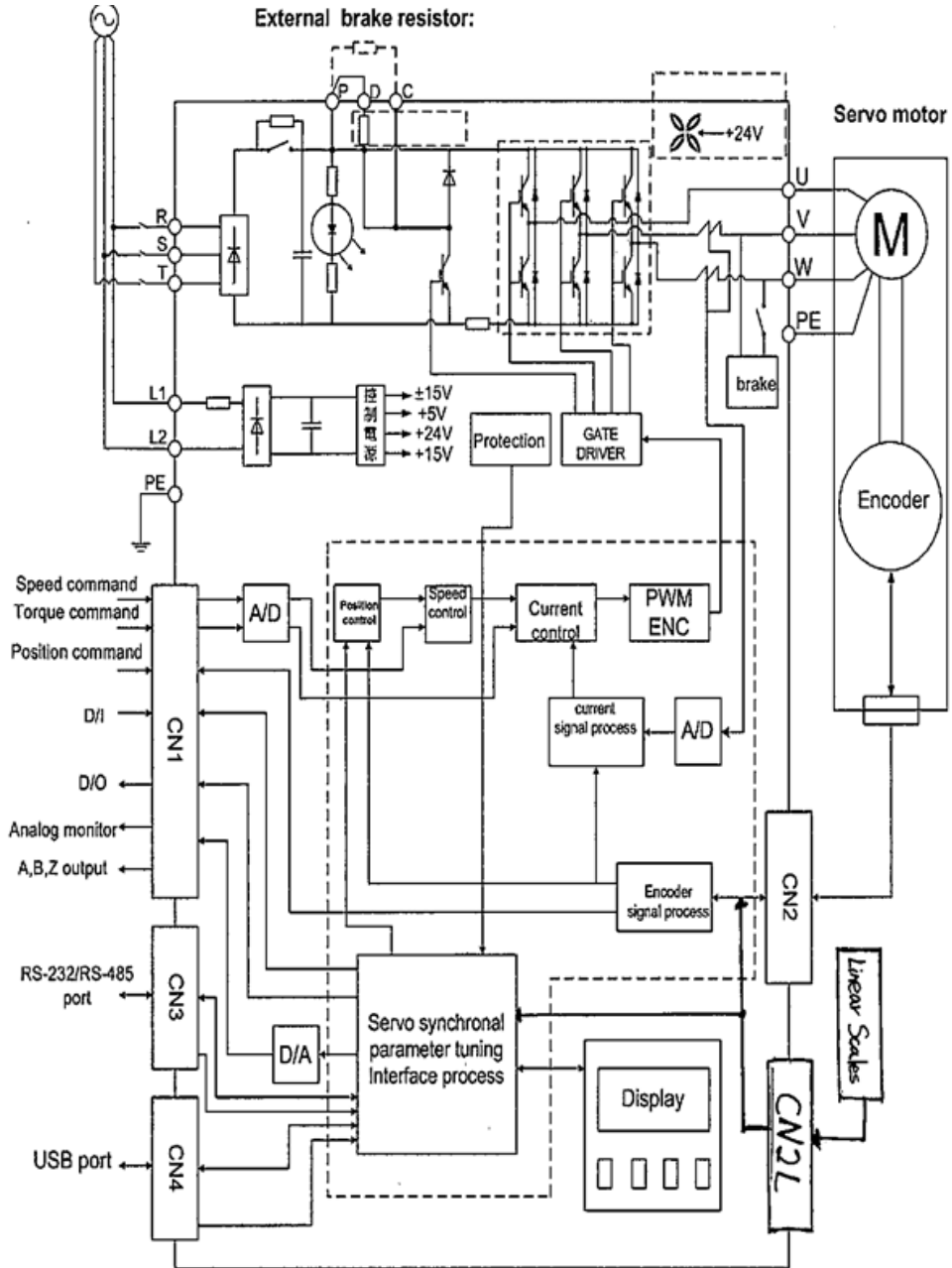

1.5KW~3.5KW:

Shihlin servo driver

Capacity: 1.5KW~3.5KW
 Power source: 200V~230V

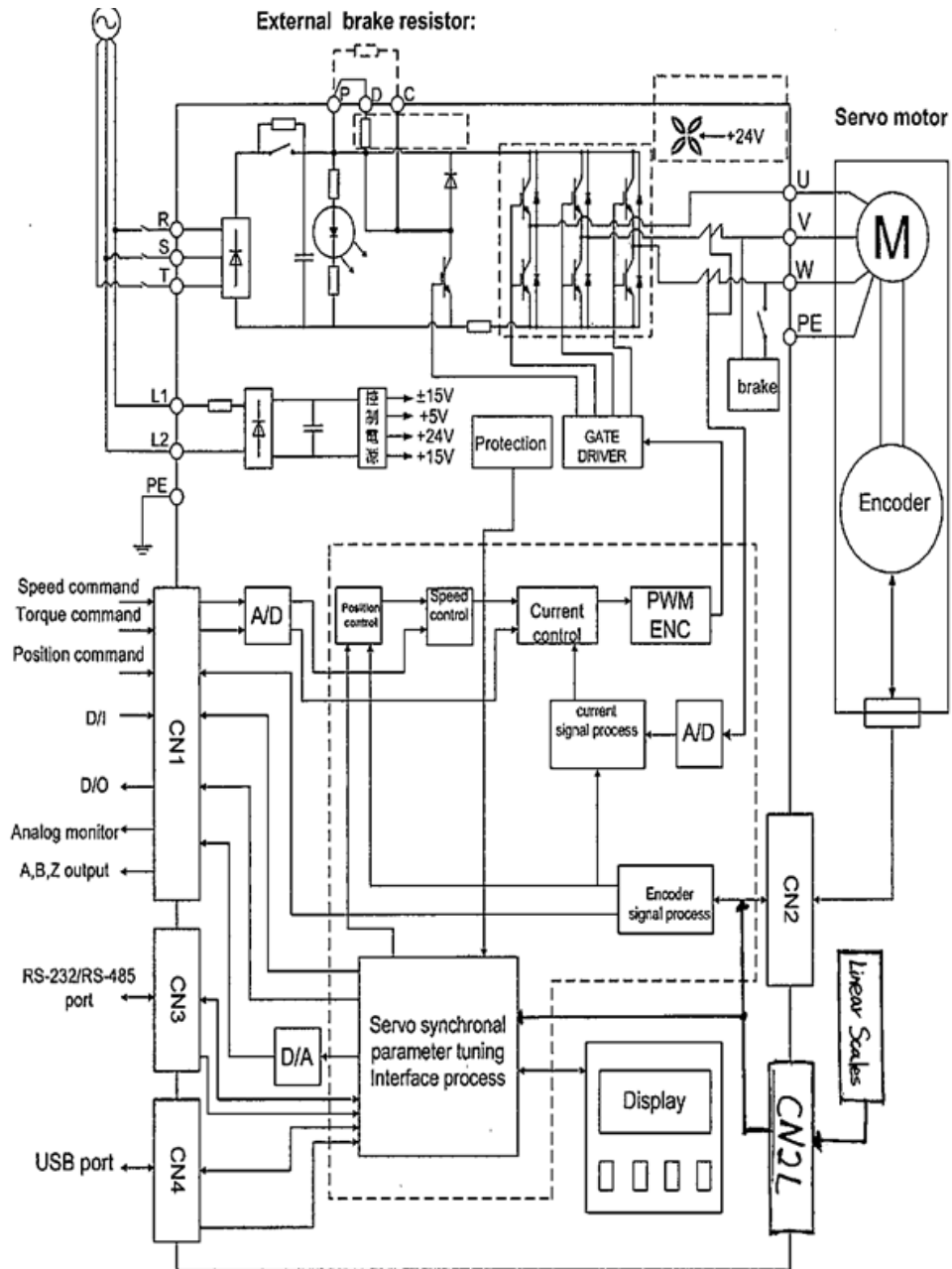

5KW~7KW:

Shihlin servo driver

Capacity: 5KW~7KW
 Power source: 200V~230V

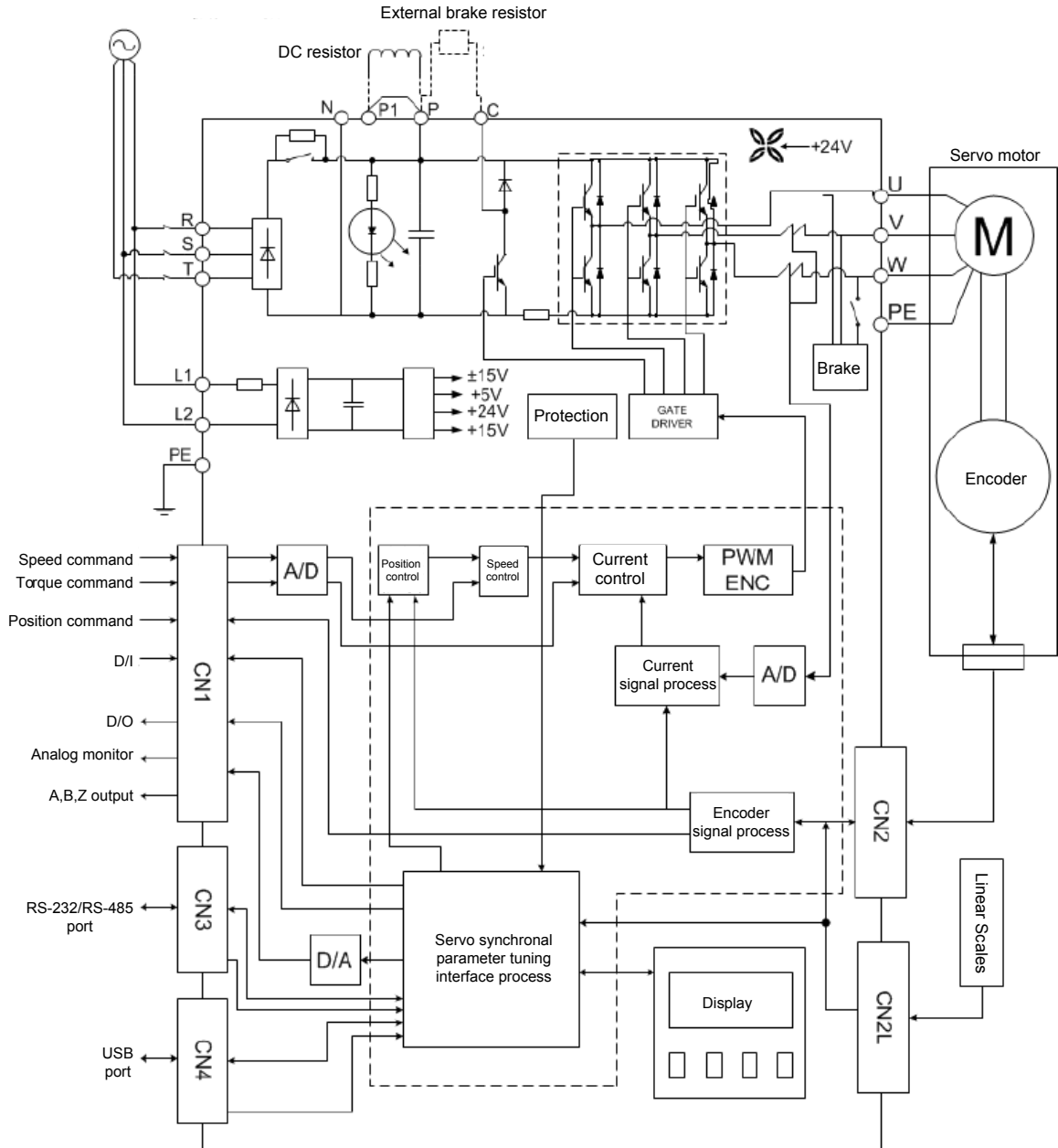

3.3 CN1 I/O Signal wires instruction

3.3.1 CN1 terminal layout

Shihlin servo drive provides 12 sets of DI inputs and 6 sets of DO outputs for users to program, which makes the application with the host controller more flexible. The 12 input DI parameters for users are PD02 to PD09, and PD21 to PD24. And the 6 output DO parameters are PD10 to PD14 and PD26. In addition, it affords encoders encoder differential output signals, A+/A-/B+/B-/Z+/Z-, torque analog command input, speed analog command input. The CN1 pin diagram is presented as follows:

(1) CN1 Connector (female)

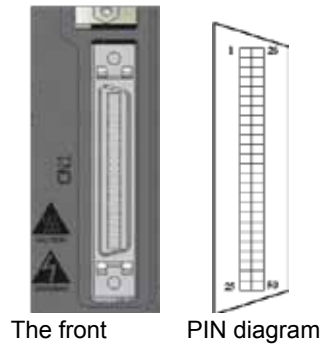

(2) CN1 Connector (male)

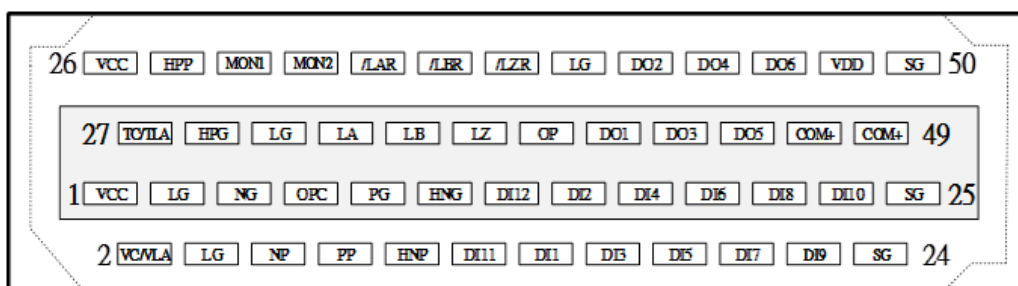
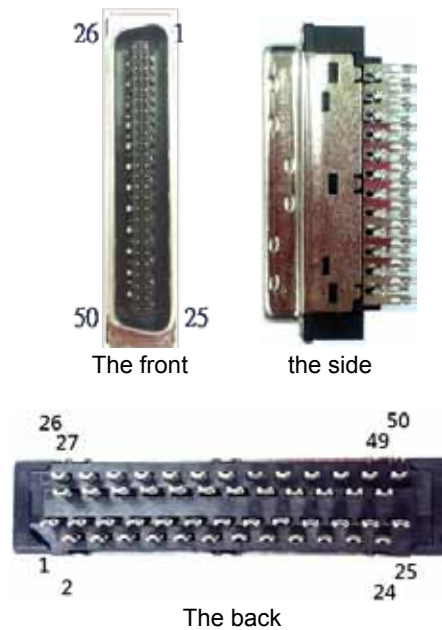

The wires of CN1 in the back of connector

N0	Pin name	Signal name	No	Pin name	Signal name
1	Vcc(15V)	+15power supply output(analog command)	26	Vcc(15V)	+15power supply output(analog command)
2	VC/VLA	Speed analog command/limit	27	TC/TLA	Torque analog command/limit
3	LG	Signal ground of analog input/output	28	HPP	High forward/revere rotation pulse train(4Mpps)
4	LG	Signal ground of analog input	29	HPG	High forward/revere rotation pulse train(4Mpps)
5	NG	Forward/reverse rotation pulse train	30	MON1	Analog monitor output 1
6	NP	Forward/reverse rotation pulse rain	31	LG	Signal ground of analog input/output
7	OPC	Open collector power	32	MON2	Analog monit or output 2
8	PP	Forward/reverse rotation pulse train	33	LA	Encoder A-phase pulse
9	PG	Forward/reverse rotation pulse train	34	LAR	Encoder A-phase pulse
10	HNP	High forward/revere rotation pulse train(4Mpps)	35	LB	Encoder B-phase pulse
11	HNG	High forward/revere rotation pulse train(4Mpps)	36	LBR	Encoder B-phase pulse
12	DI11	Digital input 11	37	LZ	Encoder Z-phase pulse
13	DI12	Digital input 12	38	LZR	Encoder Z-phase pulse
14	DI1	Digital input 1	39	OP	Encoder Z-phase pulse (open collector)
15	DI2	Digital input 2	40	LG	Signal ground of analog input/output
16	DI3	Digital input 3	41	DO1	Digital input 1
17	DI4	Digital input 4	42	DO2	Digital input 2
18	DI5	Digital input 5	43	DO3	Digital input 3
19	DI6	Digital input 6	44	DO4	Digital input 4
20	DI7	Digital input 7	45	DO5	Digital input 5
21	DI8	Digital input 8	46	DO6	Digital input 6
22	DI9	Digital input 9	47	COM+	Digital power source mid-way
23	DI10	Digital input 10	48	Vdd(24V)	24V built-in power
24	SG	Signal ground of digital I/O	49	COM+	Digital power source midway
25	SG	Signal ground digital I/O	50	SG	Signal ground of digital I/O

3.3.2 Signal description of CN1 terminal

Signals listed in aforesaid section will be described in detail in this section.

1. CN1 terminal signal description

There are 50 Pins on CN1 terminal. Every pin function would be described as below:

The abbreviation for the control modes in the table below are explained as below:

Pt : Position control mode (terminal input)

Pr : Position control mode (inner register)

S : Speed control mode

T : Torque control mode

Signal name	Sign	Pin NO	Function description	Control mode
+15power supply output	Vcc(15V)	CN1-1 CN1-26	DC 15V between+15Vcc and LC. It could be used as power source of TC, TC, TLA, VC and VLA.	ALL
Speed analog command/limit	VC/VLA	CN1-2	Apply a voltage in $\pm 10V$ range on VC-LG under the speed mode, the motor will rotate the proportional speed linearly of PC 12 value at $\pm 10V$ range. Apply a voltage in $\pm 10V$ range on VLC-LG under the torque mode; the motor will rotate the proportional speed linearly of PC 12 value at $\pm 10V$ range.	S、T
Signal ground of analog input/output	LG	CN1-3 CN1-4 CN1-31 CN1-40	The common ground of TLA, TC, VC, OP, MO1, MO2, VCC. Each pin inside the drive is connected together.	ALL
Torque analog command/limit	TC/TLA	CN1-27	Apply a voltage signal within $\pm 10V$ on TC-LG, the motor torque generated would be linear proportional of PC13. As TLA is valid, motor generated torque would be limited according to proportion of rated torque to applied voltage. The range of applied voltage on TLA-LG IS $0\pm 10V$	Pt、Pr、S
Forward/reverse rotation pulse train	NG	CN1-5	Speed command rotation pulse train Open collector type: (Max. frequency 200Kpps) To apply signals on PP-SG means "forward command" To apply signals on PP-SG means "reverse command" Signal in differential type. (Max. frequency 200Kpps) To apply signals on PP-SG means "forward command" To apply signals on PP-SG means "reverse command" Command rotation plus you can refer PA12 to modify	Pt
	NP	CN1-6		
	PP	CN1-8		
	PG	CN1-9		
	HNP	CN1-10	High speed command rotation pulse train Open collector type: (Max. frequency 4Mpps) To apply signals on HPG-HPP means "forward command" To apply signals on HNG-HNP means "forward command" Command rotation plus you can refer PA12 to modify	
	HNG	CN1-11		
	HPP	CN1-28		
	HPG	CN1-29		

Signal name	Sign	Pin NO	Function description	Control mode
Open collector power	OPC	CN1-7	As signals in open collector type; this pin provides DC24V is the ground	ALL
Signal ground of digital I/O	SG	CN1-24 CN1-25 CN1-50	The common ground of SON, EMG digital input. Each pin inside the drive is connected together but separated from LC.	ALL
Analog monitor output 1	MON1	CN1-30	The proportional voltage signal according to the value of PC 14outputs on MO1-LG.	ALL
Analog monitor output 2	MON2	CN1-32	The proportional voltage signal according to the value of PC 14outputs on MO1-LG.	ALL
Encoder A-phase pulse(differential line drive)	LA	CN1-33	The value of PA 14 decides how many pulses output in one turn. The output signals are in line drive type. There is a $\pi/2$ delay between phase A and B. The phase sequence of rotation and phase difference between phase A and B could be defined by the change of PA 39 value.	ALL
	LAR	CN1-34		ALL
Encoder B-phase pulse(differential line drive)	LB	CN1-35		ALL
	LBR	CN1-36		ALL
Encoder Z-phase pulse(differential line drive)	LZ	CN1-37	The drive transforms the OP Signals into line drive.	ALL
	LZR	CN1-38		ALL
Phase Z pulse of encoder(open collector)	OP	CN1-39	The origin signal of encoder output. One pulse is output as the completion of one revolution for the servo motor.	ALL
Digital power source midway	COM+	CN1-47 CN1-49	When +24 built –in power is applied as the source of input signals, this pin should be connected to DC24V	ALL
+24Vbuilt-in power	VDD (24V)	CN1-48	There is a +24V±10% power source on +24VDD-SG.	ALL

Below are D/I and D/O signal descriptions.

2. I/O signal description of CN1 terminal

Some signals and their abbreviation reference table for the I/O signals of CN1 are presented below:

Abbr.	Signal name	Abbr.	Signal name
SON	Servo ON	CTRG	Trigger of the position command
LSP	Limit of forward rotation route	TLC	Torque limiting control
LSN	Limit of reverse rotation route	VLC	Speed limiting control
CR	Clear	RD	Ready
SP1	Speed option 1	ZSP	Zero speed detection
SP2	Speed option 2	INP	In-position ready
PC	Proportion control	SA	Speed attained
ST1	Forward rotation activated	ALM	Alarm signal output
ST2	Reverse rotation activated	OP	Encoder output pulse(Open collector)
TL	Torque limit option	LZ	Encoder Z-phase pulsed(differential line drive)
RES	Reset	LZR	
EMG	External emergency stop	LA	Encoder A-phase pulsed(differential line drive)
LOP	Control mode switch	LAR	
VC	Speed analog command	LB	Encoder B-phase pulsed(differential line drive)
VLA	Speed analog limit	LBR	
TLA	Torque analog limit	VCC	15V power supply output
TC	Torque analog command	VDD	24V built-in power
RS1	Forward rotation option	COM +	24V Digital power source midway
RS2	Reverse rotation option	SG	24Vsignal ground of digital I/O
PP	Forward/reverse rotation pulse train	OPC	Open collector power
NP		LG	15V Signal ground of analog I/O
PG		MON1	Analog monitor output 1
NG		MON2	Analog monitor output 2
HPP		SD	Shield
HNP	High speed command rotation pulse train	POS1	Position command (option1)
HPG		POS2	Position command (option2)
HNG		POS3	Position command (option3)

3. DI and DO signal description

Input DI

There are 39 signal functions could be assigned to the particular DI pin by the modification of parameter. As the below sheet:

Signal function	Sign	Factions/Applications description	Control mode																																																										
Servo ON	SON	Power on the drive and make SON short-circuit to ready (the shaft is locked). Make SON open-circuit to release (The shaft is rotatable). A virtual "Servo ON" could be achieved by the PD01.	ALL																																																										
Reset	RES	A short-circuit duration over 50Ms on RES would recover from an abnormal alarm status. Some abnormal cases would not be recovered (refer to section 11.1). Set the PD20 as PD20as XXX1, the function of reset would not work.	ALL																																																										
Proportion control	PC	A short-circuit on PC would switch the proportion-integral controller to the proportion controller (speed control). When motor in static, it outputs torque to resist the external disturbance which even only 1 pulse revolution. Once the position is done, to prevent from unnecessary jitter of motor shaft, please switch to the proportion controller.	Pt, Pr, S																																																										
Torque limit option	TL	Turn TL-SG on to make analog torque limit (TLA) valid. For details, refer to section TL1.	Pt, Pr, S																																																										
Inner torque limit option	TL1	Turn TL1- SG on to make inner torque limit 2 valid.	ALL																																																										
		<table border="1"> <thead> <tr> <th colspan="2">I/S</th> <th rowspan="2">Effect torque limit value</th> </tr> <tr> <th>TL1</th> <th>TL</th> </tr> </thead> <tbody> <tr> <td>0</td> <td>0</td> <td>Parameter PA05</td> </tr> <tr> <td>0</td> <td>1</td> <td>TLA > Parameter PA05 => Parameter PA05 TLA < Parameter PA05 => TLA</td> </tr> <tr> <td>1</td> <td>0</td> <td>Parameter PC25> Parameter PA05 => Parameter PA05 Parameter PC25< Parameter PA05 => Parameter PC25</td> </tr> <tr> <td>1</td> <td>1</td> <td>TLA > Parameter PC25 => Parameter PC25 TLA < Parameter PC25 =>TLA</td> </tr> </tbody> </table>		I/S		Effect torque limit value	TL1	TL	0	0	Parameter PA05	0	1	TLA > Parameter PA05 => Parameter PA05 TLA < Parameter PA05 => TLA	1	0	Parameter PC25> Parameter PA05 => Parameter PA05 Parameter PC25< Parameter PA05 => Parameter PC25	1	1	TLA > Parameter PC25 => Parameter PC25 TLA < Parameter PC25 =>TLA																																									
		I/S		Effect torque limit value																																																									
		TL1			TL																																																								
		0		0	Parameter PA05																																																								
0	1	TLA > Parameter PA05 => Parameter PA05 TLA < Parameter PA05 => TLA																																																											
1	0	Parameter PC25> Parameter PA05 => Parameter PA05 Parameter PC25< Parameter PA05 => Parameter PC25																																																											
1	1	TLA > Parameter PC25 => Parameter PC25 TLA < Parameter PC25 =>TLA																																																											
<p>Speed control mode. Used to select the speed command. When using SP3, make it usable by making the setting.</p> <table border="1"> <thead> <tr> <th rowspan="2">Setting</th> <th colspan="3">Input signals</th> <th rowspan="2">Speed command</th> </tr> <tr> <th>SP3</th> <th>SP2</th> <th>SP1</th> </tr> </thead> <tbody> <tr> <td rowspan="4">When speed option(SP3) is not used. (initial status)</td> <td>0</td> <td>0</td> <td>0</td> <td>Speed analog command(VC)</td> </tr> <tr> <td>0</td> <td>0</td> <td>1</td> <td>Inner speed command 1</td> </tr> <tr> <td>0</td> <td>1</td> <td>0</td> <td>Inner speed command 2</td> </tr> <tr> <td>0</td> <td>1</td> <td>1</td> <td>Inner speed command 3</td> </tr> <tr> <td rowspan="7">When speed option (SP3 is made valid.</td> <td>0</td> <td>0</td> <td>0</td> <td>Speed analog command (VC)</td> </tr> <tr> <td>0</td> <td>0</td> <td>1</td> <td>Inner speed command 1</td> </tr> <tr> <td>0</td> <td>1</td> <td>0</td> <td>Inner speed command 2</td> </tr> <tr> <td>0</td> <td>1</td> <td>1</td> <td>Inner speed command 3</td> </tr> <tr> <td>1</td> <td>0</td> <td>0</td> <td>Inner speed command 4</td> </tr> <tr> <td>1</td> <td>0</td> <td>1</td> <td>Inner speed command 5</td> </tr> <tr> <td>1</td> <td>1</td> <td>0</td> <td>Inner speed command 6</td> </tr> <tr> <td>1</td> <td>1</td> <td>1</td> <td>Inner speed command 7</td> </tr> </tbody> </table>			Setting	Input signals			Speed command	SP3	SP2	SP1	When speed option(SP3) is not used. (initial status)	0	0	0	Speed analog command(VC)	0	0	1	Inner speed command 1	0	1	0	Inner speed command 2	0	1	1	Inner speed command 3	When speed option (SP3 is made valid.	0	0	0	Speed analog command (VC)	0	0	1	Inner speed command 1	0	1	0	Inner speed command 2	0	1	1	Inner speed command 3	1	0	0	Inner speed command 4	1	0	1	Inner speed command 5	1	1	0	Inner speed command 6	1	1	1	Inner speed command 7	S,T
Setting	Input signals			Speed command																																																									
	SP3	SP2	SP1																																																										
When speed option(SP3) is not used. (initial status)	0	0	0	Speed analog command(VC)																																																									
	0	0	1	Inner speed command 1																																																									
	0	1	0	Inner speed command 2																																																									
	0	1	1	Inner speed command 3																																																									
When speed option (SP3 is made valid.	0	0	0	Speed analog command (VC)																																																									
	0	0	1	Inner speed command 1																																																									
	0	1	0	Inner speed command 2																																																									
	0	1	1	Inner speed command 3																																																									
	1	0	0	Inner speed command 4																																																									
	1	0	1	Inner speed command 5																																																									
	1	1	0	Inner speed command 6																																																									
1	1	1	Inner speed command 7																																																										
<p>Torque control mode. Used to select the limit speed for operation.</p> <table border="1"> <thead> <tr> <th rowspan="2">Setting</th> <th colspan="3">Input signals</th> <th rowspan="2">Speed command</th> </tr> <tr> <th>SP3</th> <th>SP2</th> <th>SP1</th> </tr> </thead> <tbody> <tr> <td rowspan="4">When speed option(SP3) is not used. (initial status)</td> <td>0</td> <td>0</td> <td>0</td> <td>Speed analog command(VC)</td> </tr> <tr> <td>0</td> <td>0</td> <td>1</td> <td>Inner speed command 1</td> </tr> <tr> <td>0</td> <td>1</td> <td>0</td> <td>Inner speed command 2</td> </tr> <tr> <td>0</td> <td>1</td> <td>1</td> <td>Inner speed command 3</td> </tr> <tr> <td rowspan="7">When speed option(SP3 is made valid</td> <td>0</td> <td>0</td> <td>0</td> <td>Speed analog command (VC)</td> </tr> <tr> <td>0</td> <td>0</td> <td>1</td> <td>Inner speed command 1</td> </tr> <tr> <td>0</td> <td>1</td> <td>0</td> <td>Inner speed command 2</td> </tr> <tr> <td>0</td> <td>1</td> <td>1</td> <td>Inner speed command 3</td> </tr> <tr> <td>1</td> <td>0</td> <td>0</td> <td>Inner speed command 4</td> </tr> <tr> <td>1</td> <td>0</td> <td>1</td> <td>Inner speed command 5</td> </tr> <tr> <td>1</td> <td>1</td> <td>0</td> <td>Inner speed command 6</td> </tr> <tr> <td>1</td> <td>1</td> <td>1</td> <td>Inner speed command 7</td> </tr> </tbody> </table>			Setting	Input signals			Speed command	SP3	SP2	SP1	When speed option(SP3) is not used. (initial status)	0	0	0	Speed analog command(VC)	0	0	1	Inner speed command 1	0	1	0	Inner speed command 2	0	1	1	Inner speed command 3	When speed option(SP3 is made valid	0	0	0	Speed analog command (VC)	0	0	1	Inner speed command 1	0	1	0	Inner speed command 2	0	1	1	Inner speed command 3	1	0	0	Inner speed command 4	1	0	1	Inner speed command 5	1	1	0	Inner speed command 6	1	1	1	Inner speed command 7	
Setting	Input signals			Speed command																																																									
	SP3	SP2	SP1																																																										
When speed option(SP3) is not used. (initial status)	0	0	0	Speed analog command(VC)																																																									
	0	0	1	Inner speed command 1																																																									
	0	1	0	Inner speed command 2																																																									
	0	1	1	Inner speed command 3																																																									
When speed option(SP3 is made valid	0	0	0	Speed analog command (VC)																																																									
	0	0	1	Inner speed command 1																																																									
	0	1	0	Inner speed command 2																																																									
	0	1	1	Inner speed command 3																																																									
	1	0	0	Inner speed command 4																																																									
	1	0	1	Inner speed command 5																																																									
	1	1	0	Inner speed command 6																																																									
1	1	1	Inner speed command 7																																																										
Speed option 1	SP1																																																												
Speed option 2	SP2																																																												
Speed option 3	SP3																																																												

Forward rotation activated	ST1	Used to start the servo motor in the following directions:		S																		
Reverse rotation activated	ST2	Input signal			Servo motor starting direction																	
		ST2	ST1																			
		0	0			Stop(servo lock)																
		0	1			CCW																
1	0	CW																				
1	1	Stop(servo lock)																				
If both ST1 and ST2 are switched ON or OFF during operation, the servo will be decelerated to a stop according to the value of PC18 and the motor will be locked. The activation of analog speed commands (VC) at 0V will not servo lock.																						
Forward rotation option	RS1	Used to select any of the following servo motor torque generation directions:		T																		
Reverse rotation option	RS2	Input signals Torque generation direction			Torque generation direction																	
		RS2	RS1																			
		0	0			Torque is not generated																
		0	1			Forward rotation torque, reverse rotation regeneration																
1	0	Reverse rotation torque, forward rotation regeneration																				
1	1	Torque is not generated.																				
Origin position	ORGP	In position control with inner registers, this signal activated would assign current position to the origin. When is in SHOM ON, go back origin position.		Pr																		
Start Home moving	SHOM	As the signal activated, drive runs motor to return the origin.		Pr																		
Electronic gear option1	CM1	When using CM1 and CM2, make them usable by the setting. The combination of CM1 and CM2 give you a choice of 4 numerators. CM1 and CM2 cannot be used in the absolute position detection system.		Pt,Pr																		
Electronic gear option2	CM2	<table border="1"> <thead> <tr> <th colspan="2">Input signal</th> <th rowspan="2">Electronic gear molecule</th> </tr> <tr> <th>CM2</th> <th>CM1</th> </tr> </thead> <tbody> <tr> <td>0</td> <td>0</td> <td>PA06 (CMX)</td> </tr> <tr> <td>0</td> <td>1</td> <td>PC32 (CMX2)</td> </tr> <tr> <td>1</td> <td>0</td> <td>PC33 (CMX3)</td> </tr> <tr> <td>1</td> <td>1</td> <td>PC34 (CMX4)</td> </tr> </tbody> </table>		Input signal		Electronic gear molecule	CM2	CM1	0	0	PA06 (CMX)	0	1	PC32 (CMX2)	1	0	PC33 (CMX3)	1	1	PC34 (CMX4)		
Input signal		Electronic gear molecule																				
CM2	CM1																					
0	0	PA06 (CMX)																				
0	1	PC32 (CMX2)																				
1	0	PC33 (CMX3)																				
1	1	PC34 (CMX4)																				
Clear	CR	Turn CR-SG on to clear the position control counter droop pulses on its leading edge. The pulse width should be 10ms or longer. When the PD18 setting is xxx1 (The pulse are always cleared while is CR ON)		Pt,Pr																		
Gain switch option	CDP	When using this signal, make it usable by the setting. Turn CDP-SG on to change the gain values into the multiplier of parameter.		ALL																		
Control mode switch	LOP	<p>Position/Speed control switch mode. Used to select the control mode in the position/speed control switch mode.</p> <table border="1"> <thead> <tr> <th>LOP</th> <th>Control mode</th> </tr> </thead> <tbody> <tr> <td>0</td> <td>Position</td> </tr> <tr> <td>1</td> <td>Speed</td> </tr> </tbody> </table> <p>Speed/Torque control switch mode. Used to select the control mode in the Speed/Torque control switch mode.</p> <table border="1"> <thead> <tr> <th>LOP</th> <th>Control mode</th> </tr> </thead> <tbody> <tr> <td>0</td> <td>Speed</td> </tr> <tr> <td>1</td> <td>Torque</td> </tr> </tbody> </table> <p>Torque/Position control switch mode. Used to select the control mode in the Torque/Position control switch mode.</p> <table border="1"> <thead> <tr> <th>LOP</th> <th>Control mode</th> </tr> </thead> <tbody> <tr> <td>0</td> <td>Torque</td> </tr> <tr> <td>1</td> <td>Position</td> </tr> </tbody> </table>		LOP	Control mode	0	Position	1	Speed	LOP	Control mode	0	Speed	1	Torque	LOP	Control mode	0	Torque	1	Position	Refer to Functions/ Application
LOP	Control mode																					
0	Position																					
1	Speed																					
LOP	Control mode																					
0	Speed																					
1	Torque																					
LOP	Control mode																					
0	Torque																					
1	Position																					
External emergency stop	EMG	In which the electromagnetic brake is on turn EMG ON, turn EMG OFF to bring the motor to an emergency stop state. To set the value of PD01 as 1 □□□, this signal would be normal ON.		ALL																		

Position command option1	POS1	<table border="1"> <thead> <tr> <th>Position command</th> <th>POS6</th> <th>POS5</th> <th>POS4</th> <th>POS3</th> <th>POS2</th> <th>POS1</th> <th>CTRG</th> </tr> </thead> <tbody> <tr> <td>PO</td> <td>0</td> <td>0</td> <td>0</td> <td>0</td> <td>0</td> <td>0</td> <td>↑</td> </tr> <tr> <td>P1</td> <td>0</td> <td>0</td> <td>0</td> <td>0</td> <td>0</td> <td>1</td> <td>↑</td> </tr> <tr> <td>~</td> <td></td> <td></td> <td></td> <td></td> <td></td> <td></td> <td></td> </tr> <tr> <td>P50</td> <td>1</td> <td>1</td> <td>0</td> <td>0</td> <td>0</td> <td>1</td> <td>↑</td> </tr> <tr> <td>P51</td> <td>1</td> <td>1</td> <td>0</td> <td>0</td> <td>1</td> <td>1</td> <td>↑</td> </tr> <tr> <td>~</td> <td></td> <td></td> <td></td> <td></td> <td></td> <td></td> <td></td> </tr> <tr> <td>P63</td> <td>1</td> <td>1</td> <td>1</td> <td>1</td> <td>1</td> <td>1</td> <td>↑</td> </tr> </tbody> </table>	Position command	POS6	POS5	POS4	POS3	POS2	POS1	CTRG	PO	0	0	0	0	0	0	↑	P1	0	0	0	0	0	1	↑	~								P50	1	1	0	0	0	1	↑	P51	1	1	0	0	1	1	↑	~								P63	1	1	1	1	1	1	↑	Pr
Position command	POS6		POS5	POS4	POS3	POS2	POS1	CTRG																																																											
PO	0		0	0	0	0	0	↑																																																											
P1	0		0	0	0	0	1	↑																																																											
~																																																																			
P50	1		1	0	0	0	1	↑																																																											
P51	1		1	0	0	1	1	↑																																																											
~																																																																			
P63	1	1	1	1	1	1	↑																																																												
Position command option2	POS2																																																																		
Position command option3	POS3																																																																		
Position command option4	POS4																																																																		
Position command option5	POS5																																																																		
Position command option6	POS6																																																																		
Position command trigger	CTRG	In position control with inner 6 registers (Pr mode), the combination of POS1 to POS6 gives you a choice of 6 position commands when the CTRG ON is activated.	Pr																																																																
Inner position command halt	HOLD	In position control with inner, the motor would stop running as this signal activated.	Pr																																																																
Forward rotation limit switch	LSP	Forward rotation limit switch, motor can proceed with forward command when LSP is ON	Pt、Pr、S																																																																
Reverse rotation limit switch	LSN	Reverse rotation limit switch, motor can proceed with reverse command when LSN is ON.	Pt、Pr、S																																																																
Pulse input forbidden	INHP	For bit pulse input, under the position mode, when this signal is ON, input pulse command from external source will be ignored.	Pt																																																																
Trigger command PR #1	EV1	Trigger command PR 1~4, DI: depends on the condition of EV1~EV4 Set by parameter PF83 Set by parameter PF84 Situation: connected to sensor, procedure with triggering of sensor.	Pr																																																																
Trigger command PR#2	EV2																																																																		
Trigger command PR#3	EV3																																																																		
Trigger command PR#4	EV4																																																																		
DELTA ABS com. mode	ABSE	ABSE ON to enter ABS mode, activates ABSQ, ABSR, ABSD, and ABSC. When ABSE is ON: DI4, DO2, DO3 will lose their function programmed by parameter; DI4 becomes ASDQ, DO2 becomes ABSR, DO3 becomes ABSD, ABSC can define DI connection by parameters.	ALL																																																																
Mitsubishi ABS com. mode	ABSM	ABSM ON to enter ABS mode, activates ABSR, ABST, ABSB0, ABSB1, and ABSC. When ABSE is ON: DI4, DO2, DO3, DO4 will lose their function programmed by parameter; DI4 becomes ABSR, DO2 becomes ABST, DO3 becomes ABSB0, DO4 becomes ABSB1, ABSC can define DI connection by parameters.	ALL																																																																
DELTA/ Mitsubishi ABS home setting	ABSC	ABSC ON will clear the loop information stored within the absolute encoder. When ABSE or ABSM is ON, the input will be effective.	ALL																																																																
Motor stop operation signal in Pr Mode	STOP	When STOP signal is on in Pr mode, motor will stop operation.	Pr																																																																

NOTE:

1. When setting the parameter PA01 in speed mode or torque mode, the function ST1/RS2 and ST2/RS1 would be defined mutually because of the same values.
2. To use the custom definition of input signal, the value of PA01 should be as 0''''.
3. If the values of PA01 are 1''''', the DI/DO function definition of signals should be a default.

Output DO

Every DO pin is programmable. There are 14 output function could be assigned to the particular DO pin by the modification as the function described below:

Signal function	Sign	Function	Control mode
Ready	RD	It is ON as power is turned on a drive is ready to operate.	ALL
Alarm signal output	ALM	ALM-SG is isolated as power off or protection activated to cut off the main circuit. Without alarm occurring, ALM-SG would turn on after power on 1 second latter.	ALL
In-position ready	INP	INP turns ON when the number of droop pulses is in the preset in-position range. The in-position range could be change using parameter. When the in-position range is increased, INP may be kept conductive during low-speed rotation.	Pr, Pt
Speed attained	SA	SA turns ON when the speed has nearly reached the preset command. When the preset command is 50r/min or less, SA always turns ON.	S
Home moving completion	HOME	It turns ON after the completion of HOME moving.	Pr
Torque limiting control	TLC	TLG-SG is ON as motor generated torque reaches inner torque limit or torque analog limit. TLC-SG is OFF when SON signal is turn OFF.	Pr, Pt, S
Speed limiting control	VLC	In torque mode, inner speed commanded 1 to 7 OR VLA-SG is on as motor speed reaches inner speed limit or speed analog limit. VLC-SG is OFF when SON signal is turn OFF.	T
Electromagnetic brake interlock	MBR	When using this signal, make it usable by setting parameter PA01as□1□□. MBR is OFF as the power is turned off or any alarm occurred.	ALL
Warming	WNG	WNG ON is conductive as any warming occurred. Without warming occurring, WNG OFF is isolated.	ALL
Zero speed detection	ZSP	When the speed is under the preset of zero speed (50r/min), ZSP ON keeps conductive. The zero speed range could be changed.	ALL
Inner position command output completed	CMDOK	CMDOK ON is conductive as the inner position command is completed or stopped.	Pr
Reached overloading level	OLW	Over loading the setting is output is ON.	ALL
Reached internal position	MC_OK	When DO : CMD_OK and INP are both ON, Output ON, or else OFF	Pr
Position command overflow	OVF	When position command overflow, output ON	Pr
Foreword rotation soft limit reached	SWPL	When motor returned pulse bigger than (PF86), Output ON, or else OFF	Pr
Reversed rotation soft limit reached	SWNL	When motor returned pulse smaller than (PF87), Output ON, or else OFF	Pr
Alarm output for absolute system (DELTA)	ABSW	DELTA absolute system alarm output.	ALL
Absolute position lost (Mitsubishi)	ABSV	When absolute position loss with Mitsubishi absolute system, ABSV is ON.	ALL

DI value	Sign	Function	Pt	Pr	S	T	Pt-S	Pt-T	Pr-S	Pr-T	S-T
0x01	SON	Servo ON	DI1	DI1	DI1	DI1	DI1	DI1	DI1	DI1	DI1
0x02	RES	Reset	DI5	DI5	DI5	DI5	DI5	DI5	DI5	DI5	DI5
0x03	PC	Proportion control	DI3								
0x04	TL	Torque limit option	DI4		DI11	DI11	DI11	DI11			DI11
0x05	TL1	Inner torque limit option	DI11								
0x06	SP1	Speed option 1			DI6	DI6	DI2	DI2	DI11	DI11	DI6
0x07	SP2	Speed option 2			DI2	DI2					DI2
0x08	SP3	Speed option 3									
0x09	ST1	Forward rotation activated			DI3		DI3		DI3		
0x0A	ST2	Reverse rotation activated.			DI4		DI4		DI6		
0x0A	RS1	Forward rotation activated.				DI4		DI4		DI6	DI4
0x09	RS2	Reverse rotation activated				DI3		DI3		DI3	DI3
0x0B	ORGP	Origin positioned									
0x0C	SHOM	Star Home moving									
0x0D	CM1	Electronic gear option1	DI2								
0x0E	CM2	Electronic gear option2									
0x0F	CR	Clear	DI6	DI6			DI6	DI6			
0x10	CDP	Gain switch option	DI12		DI12	DI12	DI12	DI12			DI12
0x11	LOP	Control mode switch	DI8		DI8	DI8	DI8	DI8	DI8	DI8	DI8
0x12	EMG	External emergency stop	DI7	DI7	DI7	DI7	DI7	DI7	DI7	DI7	DI7
0x13	POS1	Position command option1		DI2					DI2	DI2	
0x14	POS2	Position command option 2		DI3					DI12	DI12	
0x15	POS3	Position command option 3		DI8							
0x16	CTRG	Position command trigger		DI4					DI4	DI4	
0x17	HOLD	Inner position command halt									
0x18	LSP	Foreword rotation stroke limit	DI9	DI9	DI9	DI9	DI9	DI9	DI9	DI9	DI9

NOTE:

1. When setting the parameter PA01 in speed mode or torque mode, the function INP and SA would be defined mutually because of the same values.
2. When setting the parameter PA01 in speed mode or torque mode, the function TLC AND VLC would be defined mutually because of the same values.

There are 12 DI (PD 02~PD 09 and PD21~PD24) and 6DO (PD 10 to PD 14 and PD26) in CN1.They afford user a flexible application. See as follows sheet.

DI input function with command values.

DI Value	Sign	Function	Pt	Pr	S	T	Pt-S	Pt-T	Pr-S	Pr-T	S-T
0x19	LSN	Reverse rotation stroke limit	DI10	DI10	DI10	DI10	DI10	DI10	DI10	DI10	DI10
0x1A	POS4	Position command option 4		DI11							
0x1B	POS5	Position command option 5		DI12							
0x1C	POS6	Position command option 6									
0x1D	INHP	Pulse input OFF									
0x1E	EV1	Trigger command Pr #1									
0x1F	EV2	Trigger command Pr #2									
0x20	EV3	Trigger command Pr #3									
0x21	EV4	Trigger command Pr #4									
0x22	ABSE	DELTA absolute system enabler									
0x22	ABSM	Mitsubishi absolute system enabler									
0x23	ABSC	Absolute system home setting									
0x24	STOP	PR mode motor stopping signal									

DO output function with commanded values

Value	Sign	Function	Pt	Pr	S	T	Pt-S	Pt-T	Pr-S	Pr-T	S-T
0x01	RD	Ready	DO5	DO5	DO5	DO5	DO5	DO5	DO5	DO5	DO5
0x02	ALM	Trouble	DO6	DO6	DO6	DO6	DO6	DO6	DO6	DO6	DO6
0x03	INP	In-position ready	DO1	DO1			DO1	DO1	DO1	DO1	
0x03	SA	Speed attained			DO1		DO1		DO1		DO1
0x04	HOME	Home return									
0x05	TLC	Torque limiting control	DO4	DO4	DO4		DO4	DO4	DO4	DO4	DO4
0x05	VLC	Speed limiting control				DO4		DO4		DO4	DO4
0X06	MBR	Electromagnetic brake interlock			DO3	DO3					DO3
0x07	WNG	Warning	DO3			DO1	DO3	DO3			
0x08	ZSP	Zero speed detection	DO2	DO2	DO2	DO2	DO2	DO2	DO2	DO2	DO2
0x09	CMDOK	Inner position command output completed		DO3					DO3	DO3	
0x0A	OLW	Reached over loading level									
0x0B	MC_OK	CMDOK and INP reached level									
0x0C	OVF	Position command overflow									
0x0D	SWPL	Output for forward position reached soft limit									
0x0E	SWNL	Output for reverse position reached soft limit									
0x0F	ABSW	Alarm output for absolute system (DELTA)									
0x10	ABSV	Absolute position lost (Mitsubishi)									

3.3.3 Interface wiring diagram

(1) Digital input interface DI

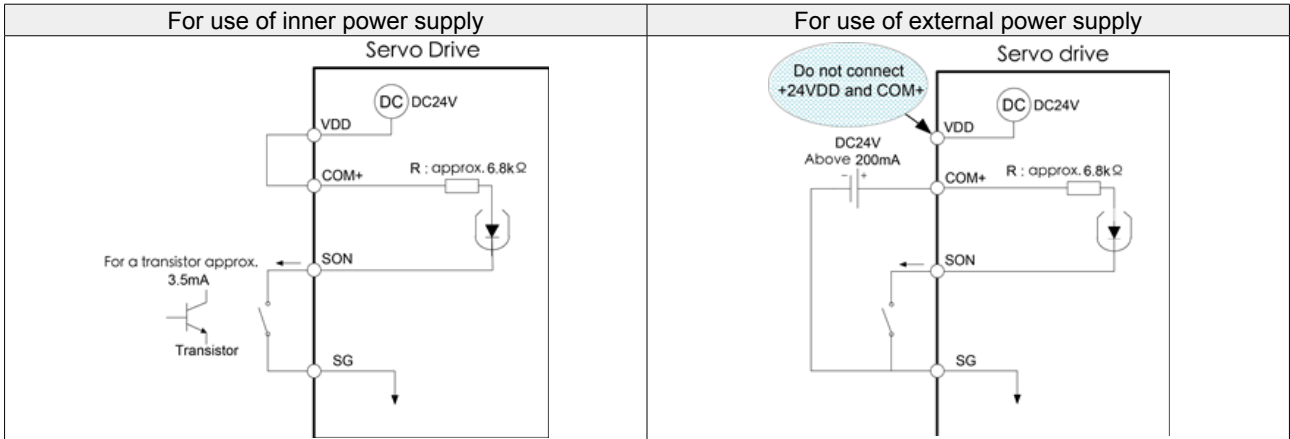

(2) Source input interface

When using the input interface of source type, all DI input signals are of source type. Source output could not be provided.

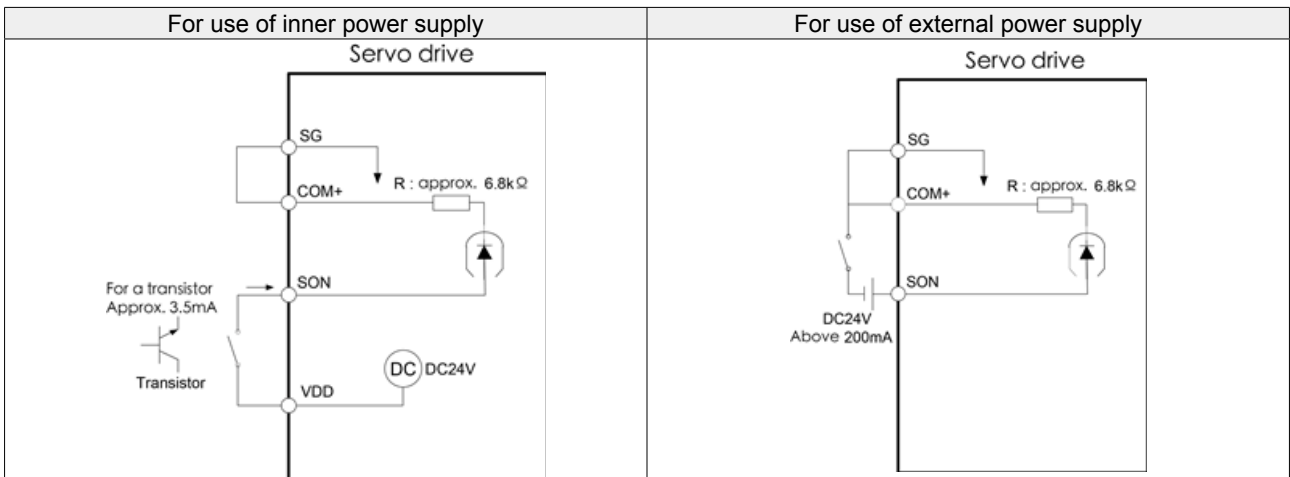

(3) Digital output interface DO

Lamp, Relay or photo coupler could be driven. A diode for relay load or a suppressing resistor for lamp load is necessary. (Permissible current: 40mA or less, inrush current: 100mA or less)

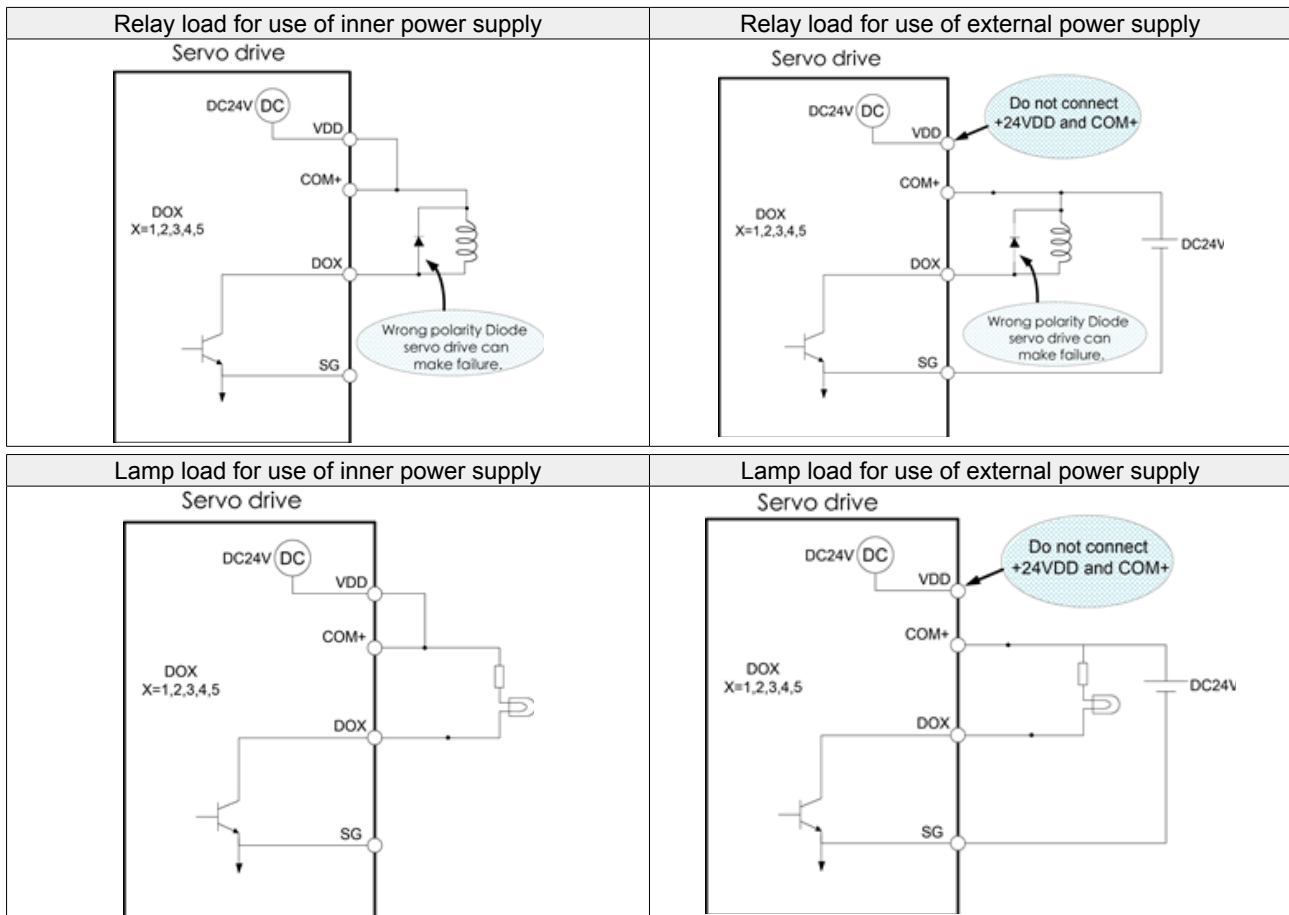

(4) Speed analog command, torque analog command and MON1, MON2 analog output.

Input impedance 10K Ω ~12K Ω /Output voltage \pm 10V.

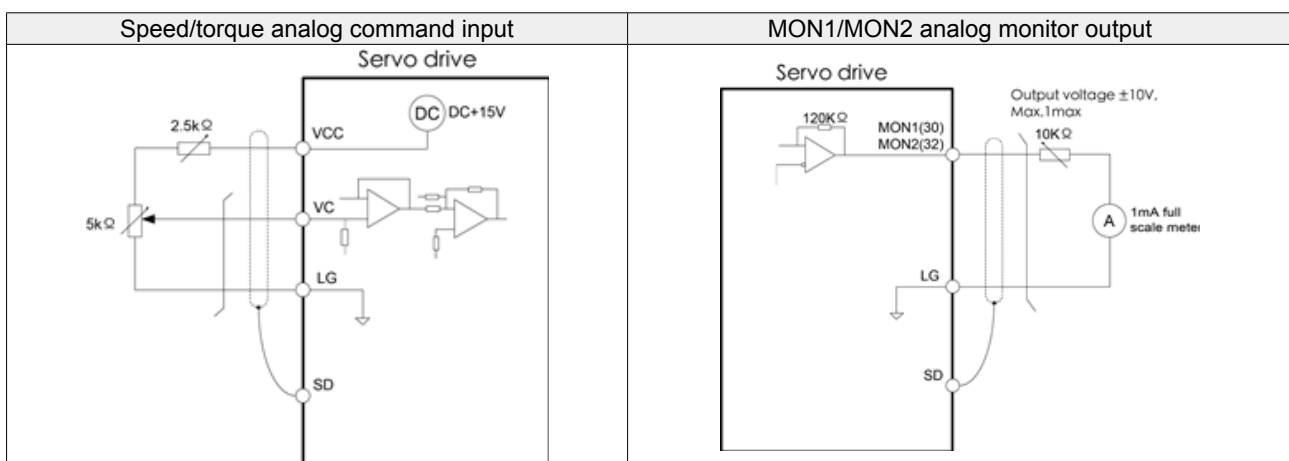

Note: VC/TC input voltage higher than 10V would damage the inner transistors of servo drive.

(5) Encoder output pulse

Output a pulse train signal in the open collector or differential Line Drive type, Open collector output could be obtained via the pin 39 (OP) of CN1. The maximum output current is 35mA.

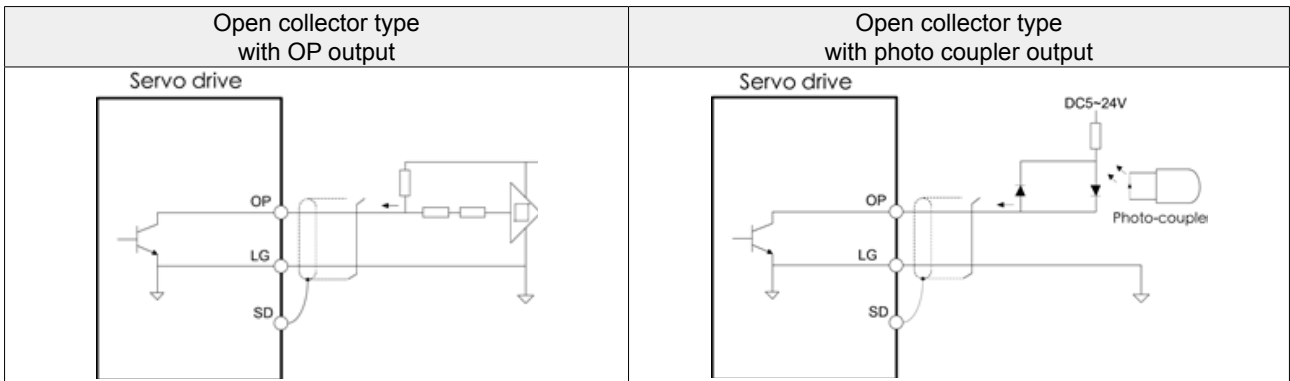

For different line drive system, the maximum output current is 20mA.

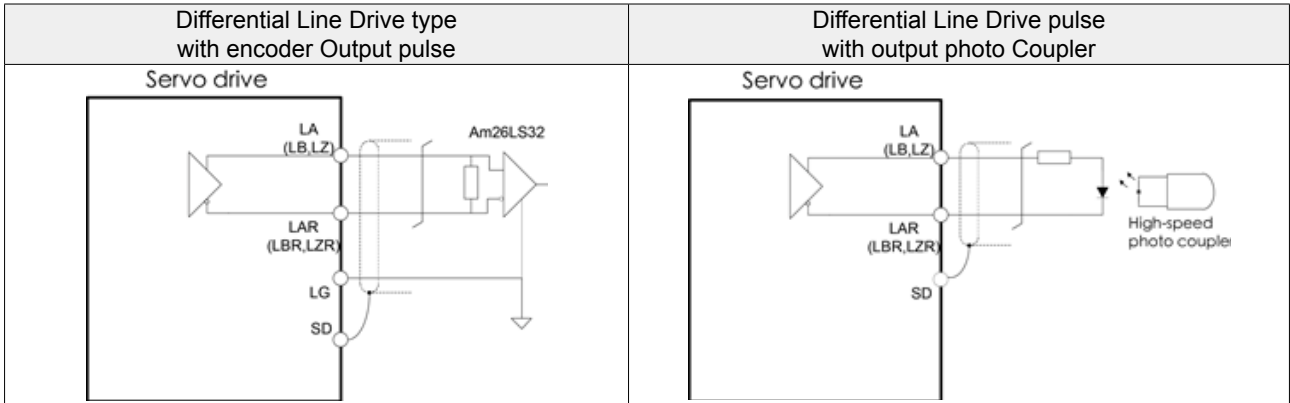

(6) Rotation pulse train input

Input a pulse train signal in open collector or differential Line drive type. The maximum input pulse frequency is 500kpps for differential Line drive, the high-speed input pulse is 4Mpps and 200kpps for open collector type.

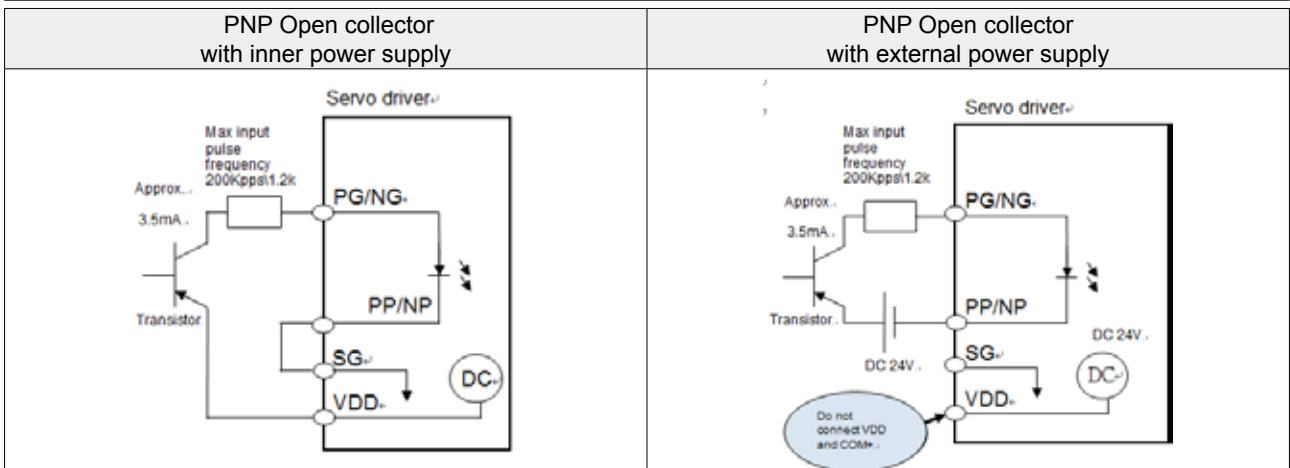
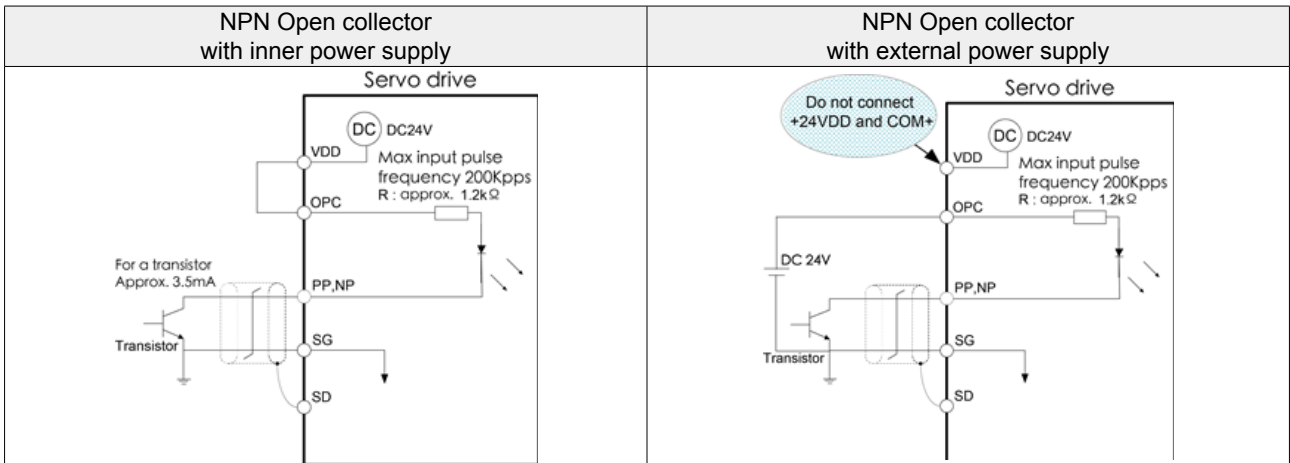

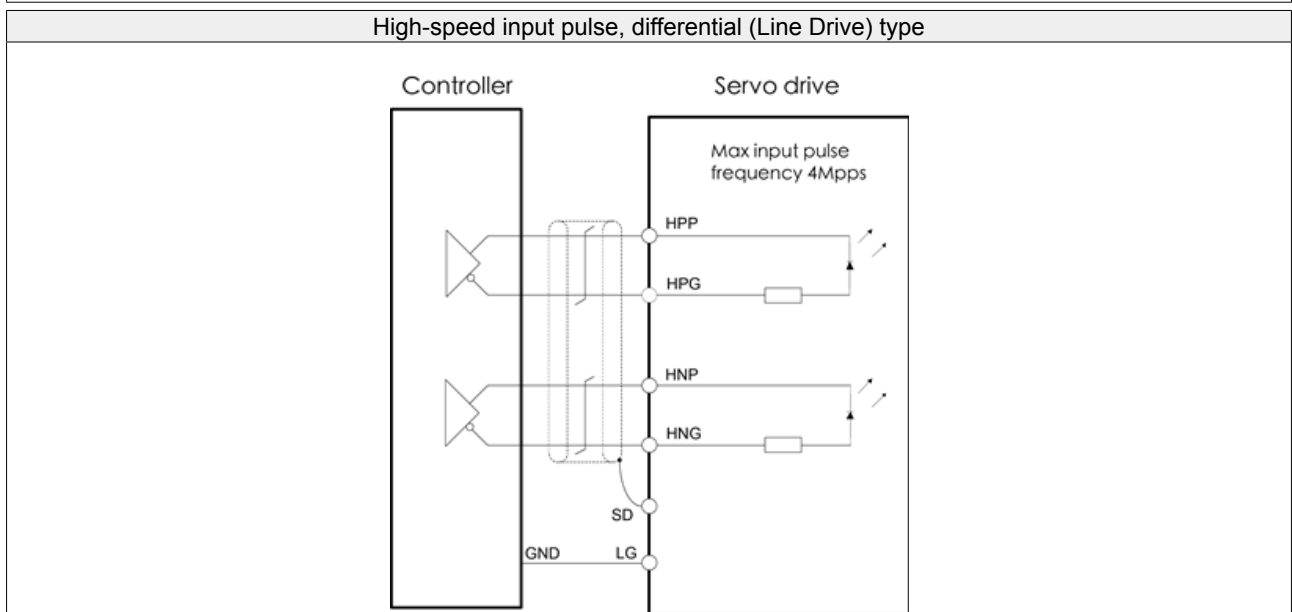
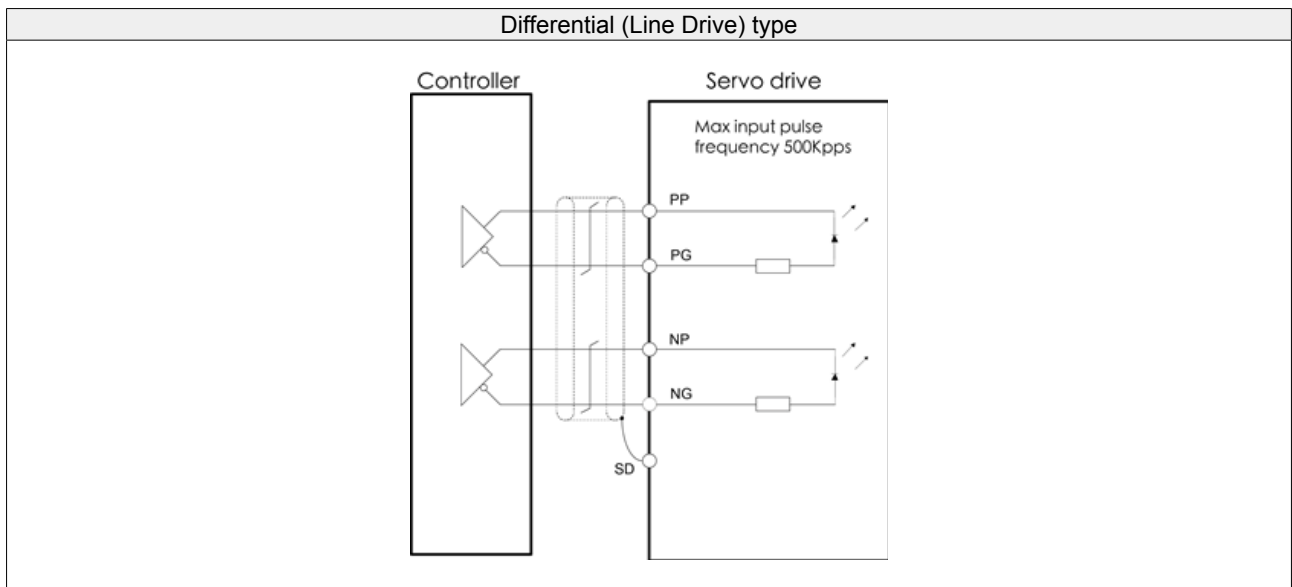

NOTE:

1. This input system is 5V. Do not be used 24V.Note
2. Suggest the controller connect with the signal ground of servo drive.

3.3.4 User definition of DI/DO signal

The DI/DO default functions are suitable for position mode. If they are not suitable for user's application, please define the functions of DI/DO AGAIN. The functions of DI1 to DI12 are corresponding to the setting of parameters PD-02 to PD-09. Those D01 to D06 are corresponding to the ones of PD21 to PD24. The following table describes the DI/DO pins of CN1 terminal and the relative parameters.

Pin No.	Pin name	Parameter
CN-14	DI1	PD 02
CN-15	DI2	PD 03
CN-16	DI3	PD 04
CN-17	DI4	PD 05
CN-18	DI5	PD 06
CN-19	DI6	PD 07
CN-20	DI7	PD 08
CN-21	DI8	PD 09
CN-22	DI9	PD 21
CN-23	DI10	PD 22
CN-12	DI11	PD 23
CN-13	DI12	PD 24

Pin No.	Pin name	Parameter
CN-41	DO1	PD 10
CN-42	DO2	PD 11
CN-43	DO3	PD 12
CN-44	DO4	PD 13
CN-45	DO5	PD 14
CN-46	DO6	PD 26

3.4 CN2 Encoder signal wiring and description

The resolution of Shihlin servo motor encoder is 22-bit. The appearance of CN2 connector is shown below:

(1) CN2 connector (Female type)

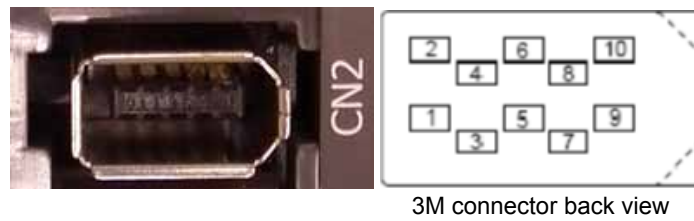

3M connector back view

(2)CN2 connector (Meal type)

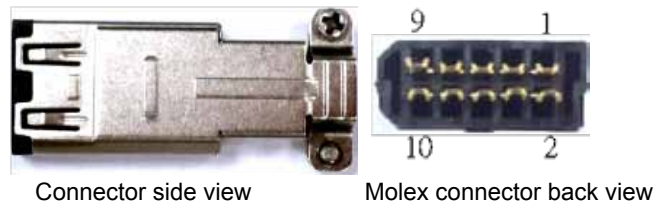

Connector side view

Molex connector back view

Table 1 – 3 – 2: CN2 Increment/Absolute encoder signal

Pin	Pin name	Signal name
1	Vcc(5V)	5V power for encoder
2	GND	Encoder ground
3	Vcc(5V)	5Vpower for encoder
4	GND	Encoder ground
5	NC	NC
6	ENCP	Encoder communication(+)
7	ENCN	Encoder communication (-)
8	NC	NC
9	NC	NC
10	NC	NC

3.4.1 Encoder signal wiring and description

The appearance of encoder cable connector of Shihlin low inertia servo motor is shown below:

Motor side:Female connector

The suitable Shihlin servo drive capacity of connector is shown below:

Drive Capacity	Motor type
100W	SMH-L010R30A□□
200W	SMH-L020R30A□□
400W	SMH-L040R30A□□
750W	SMH-L075R30A□□



Pin	Pin name	Signal name
1	NC	NC
2	NC	NC
3	VccABS(3.6V)	3.6V power for absolute encoder
4	GND	Encoder ground
5	ENCN	Encoder communication (-)
6	ENCP	Encoder communication (+)
7	Vcc(5V)	5V power for encoder
8	GND	Encoder ground
9	Shielding	Shielding

*Attention: The wiring above is connected to motor by itself.

*The meaning of □□ please refer to P2.

The appearance of encoder cable connector of Shihlin medium inertia servo motor is shown below:

Motor side: Male connector

The suitable Shihlin servo drive capacity of connector is shown below:

Drive Capacity	Motor type
500W	SMH-M050R20A□□
1KW	SMH-M100R20A□□
1.5KW	SMH-M150R20A□□
2KW	SMH-M200R20A□□
3.5KW	SMH-M350R20A□□



Pin No.	Cable color	Signal name
A	Brown	GND
B	White	5V
C	NC	NC
D	Blue	SD+
E	Purple	SD-
F	Black	GND
G	NC	NC
H	Orange	3.6V
I	NC	SHELD

*Attention: The wiring above is connected to motor by itself.

The pin definition of drive and motor:

Drive front side			Motor cable side		
Pin No.	Pin name	Signal name	Quick Connector (low inertia) Pin No.	Military Connector (medium inertia) Pin No.	Cable color
1 - 3	Vcc(5V)	5V power for encoder	7	B	White
2 - 4	GND	5V ground for encoder	8	F	Black
	GND	3.6V ground for encoder	4	A	Brown
5	VccABS	3.6V power for absolute encoder	3	H	Orange
6	ENCP	Encoder communication (+)	6	D	Black
7	ENCN	Encoder communication (-)	5	E	Purple
-	Shielding	Shielding	9	I	-

3.5 CN2L Encoder

CN2L all-closed encoder signal

CN2L Pin NO	Pin name	Description
1	Vcc (5V)	+5V output
2	GND	GND
3	Vcc (5V)	+5V output
4	GND	GND
5	A	A phase input
6	/A	/A phase input
7	B	B phase input
8	/B	/B phase input
9	Z	Z phase input
10	/Z	/Z phase input

3.6 CN3 communication port signal wiring and description

Shihlin servo drive CN3 port is for RS-232 and RS-485 communication. Via Shihlin servo software for communication, users could connect it to the computer then set parameters, monitor the status, operate and test, etc. There are 2 formats suitable for CN3: RS232 and RS485. Users could select one by setting the parameter PC21. RS-232 format has its maximum communication distance 15m. The other format RS485, it provides a longer communication distance and multiple drives' communication.

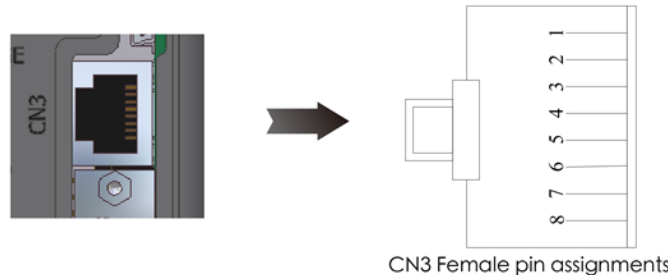

CN3 Pin NO	Sign	Function description
2	RS-485-B	Data are transmitted in differential line drive format. Line drive B.
3	RS-485-A	Data are transmitted in differential line drive format. Line drive A.
6	RS-232-RX	Data transmission, it is connected to RS-232-TX end of computer.
7	RS-232-TX	Data receiving, it is connected to RS-232-RX end of computer.
4、5	GND	Signal ground.

NOTE :

1. For RS-485 communication, please refer to section 9.1

3.7 CN4 USB communication port

For the plug-and-play usage, Shihlin servo drive provides the USB port (CN4). Similar to RS232 and RS485 of CN3, CN4 in Mini-USB type, users could connect it to the computer then set parameters, monitor the status, operate and test, etc. Mini-USB is quite common and easy to buy in the market, which help users convenient to use.

The following table describes the standard terminal specification of mini-USB:

Pin NO	Function description
1	+5V
2	D-
3	D+
4	NC
5	GND

3.8 Standard wiring method

⚠ DANGER	<ul style="list-style-type: none"> Any person who is involved in wiring and inspection should be fully competent to do the work. Before wiring, turn off the power and wait for 10 minutes or more until the charge lamp turns off. Then, confirm that the voltage is safe with a voltage tester .Otherwise, an electric shock may occur. Ground the servo drive and servo motor securely Do not attempt to wire the servo drive and servo motor until they have been installed. Otherwise, it may cause an electric shock. The cables should not be damaged, stressed, loaded, or pinched.
⚠ CAUTION	<ul style="list-style-type: none"> Correct wiring. Otherwise, a burst, damage, etc. may occur. Connect cables to the correct terminals. Otherwise, an abnormal operation, damage, etc. may occur. Ensure that polarity (+/-) is correct. Otherwise, an abnormal operation, damage, etc. may occur. The surge absorbing diode installed to the DC relay for control output should be fitted in the specified direction. Otherwise, the alarm signal cannot output, the emergency stop and other protective circuits may not operate. Use a noise filter, etc. To minimize the influence of electromagnetic interference, electromagnetic interference may be given to the electronic equipment used near the servo drive. Do not install a power capacitor, surge killer, or radio noise filter on the servo drive output side. When using the regenerative resistor, switch power off with the alarm signal. Otherwise, a regenerative resistor would be overheating, causing smoke or a fire. Do not disassemble, repair, or modify the equipment.

3.8.1 Wiring diagram of position control (Pr Mode)

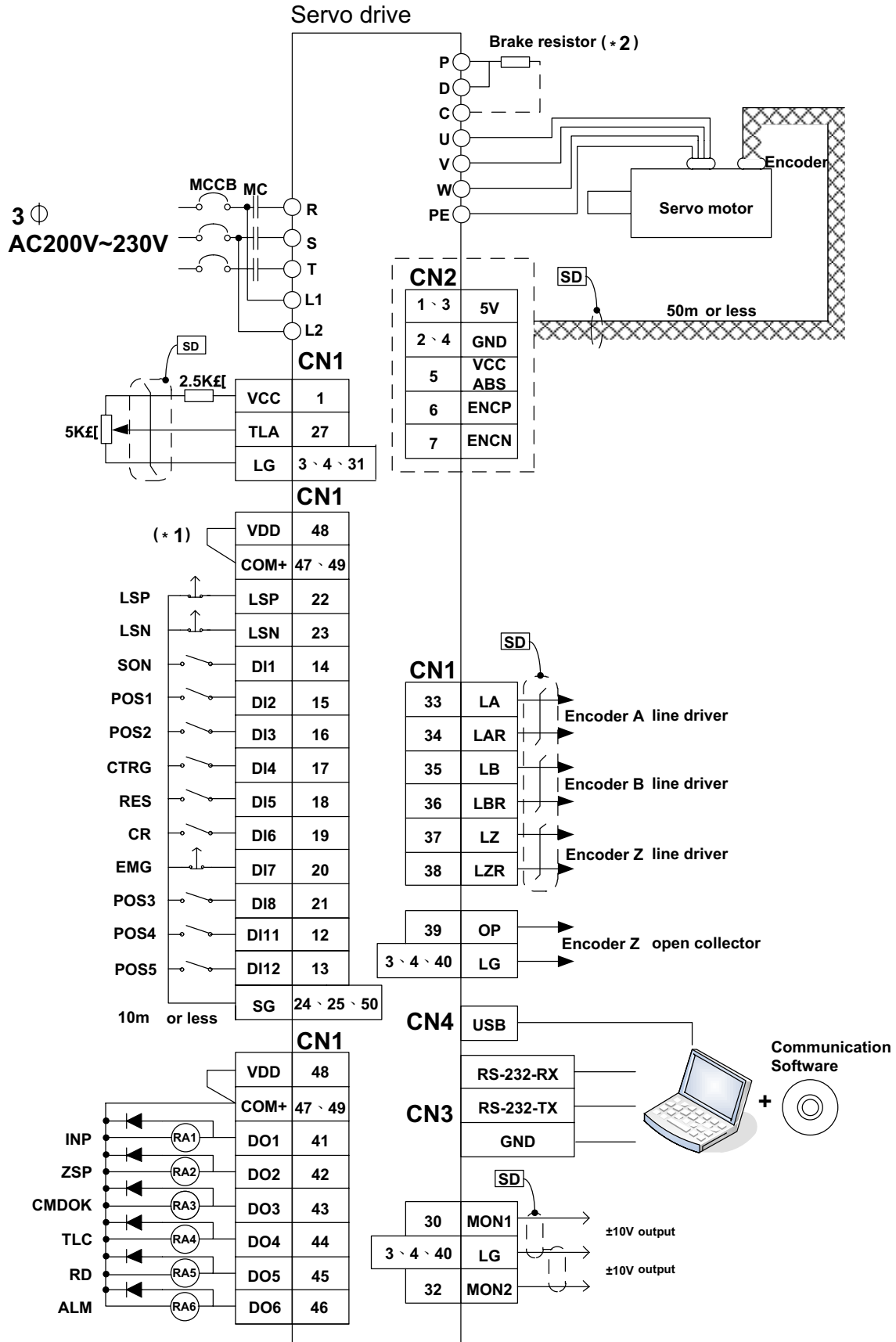

- Note
- 1.If the external power is applied, do not connect +24Vdd and COM+.
 - 2.See section 3.1.3 for the wirings of brake resistor.

3.8.2 Wiring diagram of position control (Pt Mode)

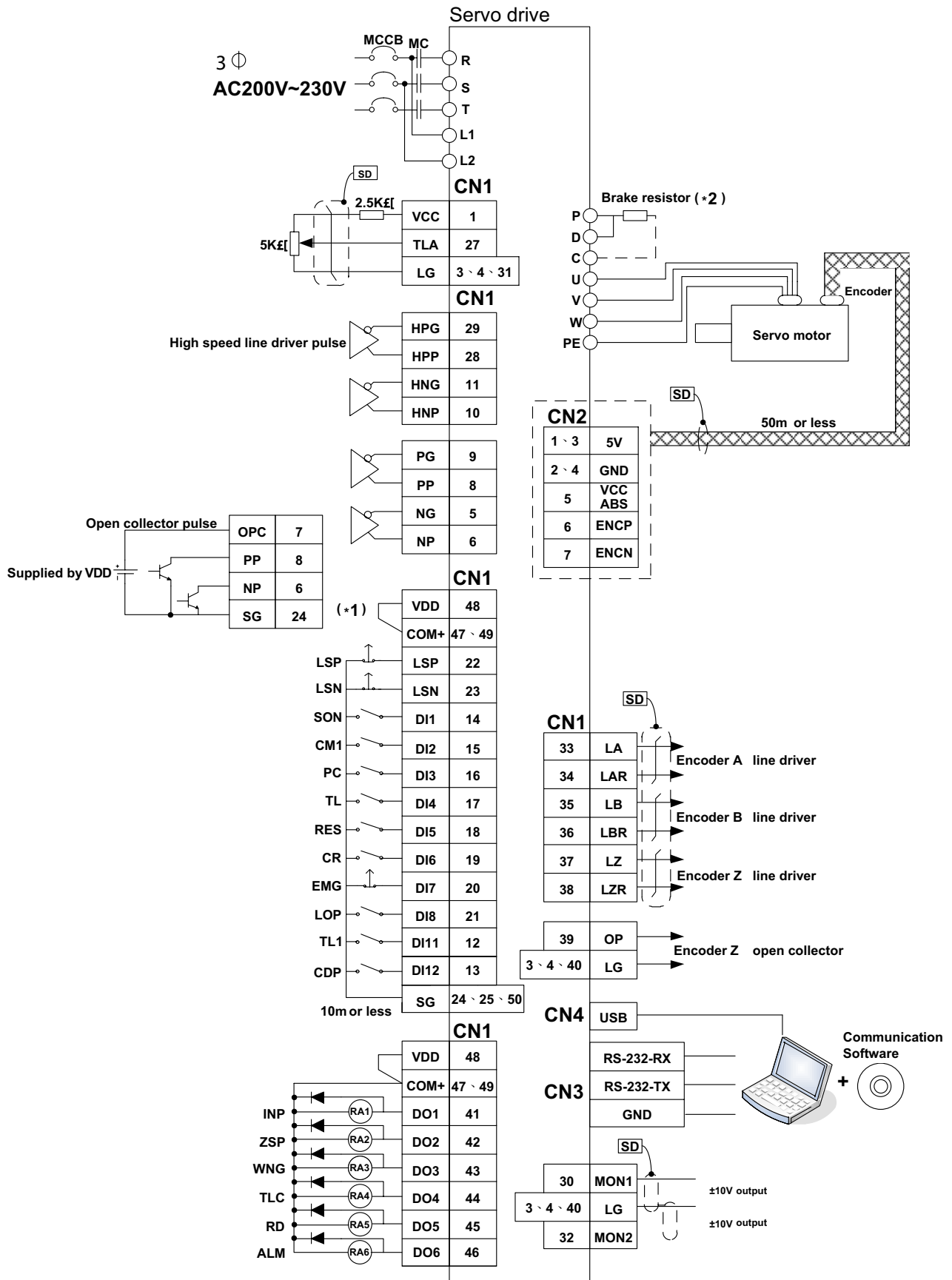

Note 1.If the external power is applied, do not connect +24Vdd and COM+.
 2.See section 3.1.3 for the wirings of brake resistor.

3.8.3 Wiring diagram of speed control (S Mode)

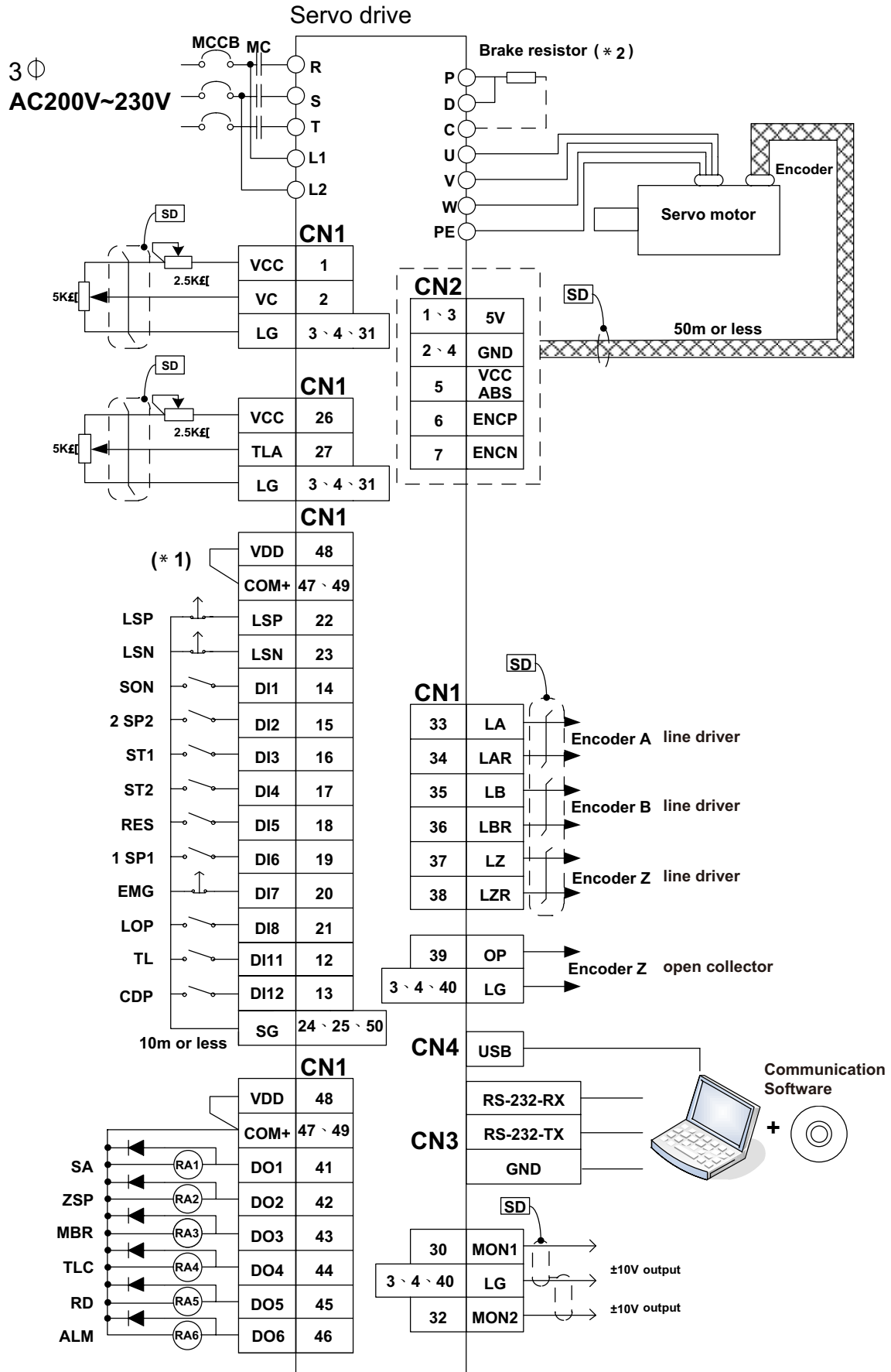

Note 1.If the external power is applied, do not connect +24Vdd and COM+.
2.See section 3.1.3 for the wirings of brake resistor.

3.8.4 Wiring diagram of torque control (T Mode)

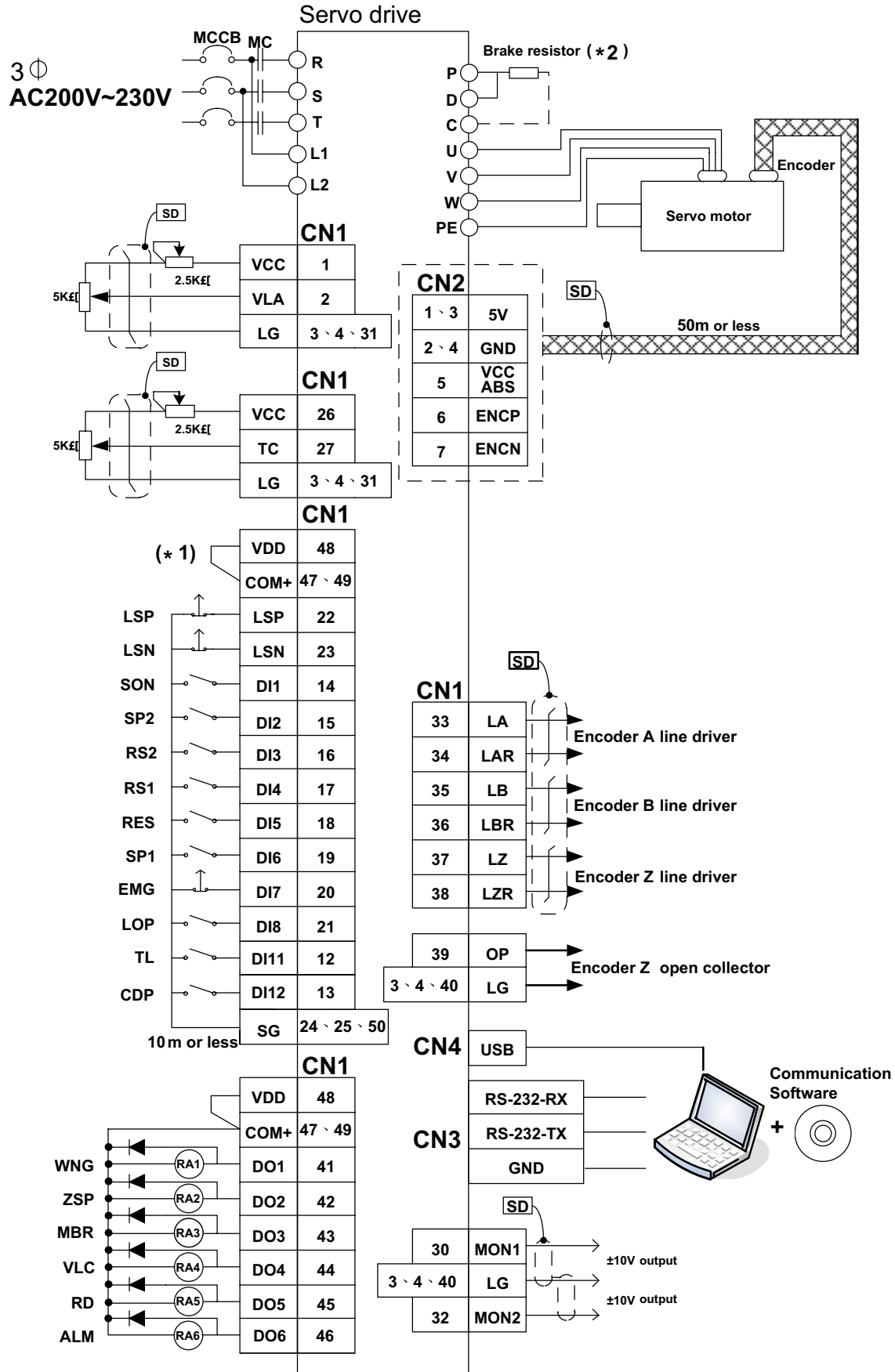

- Note
- 1.If the external power is applied, do not connect +24Vdd and COM+.
 - 2.See section 3.1.3 for the wirings of brake resistor.

3.8.5 Wiring diagram with 1PG

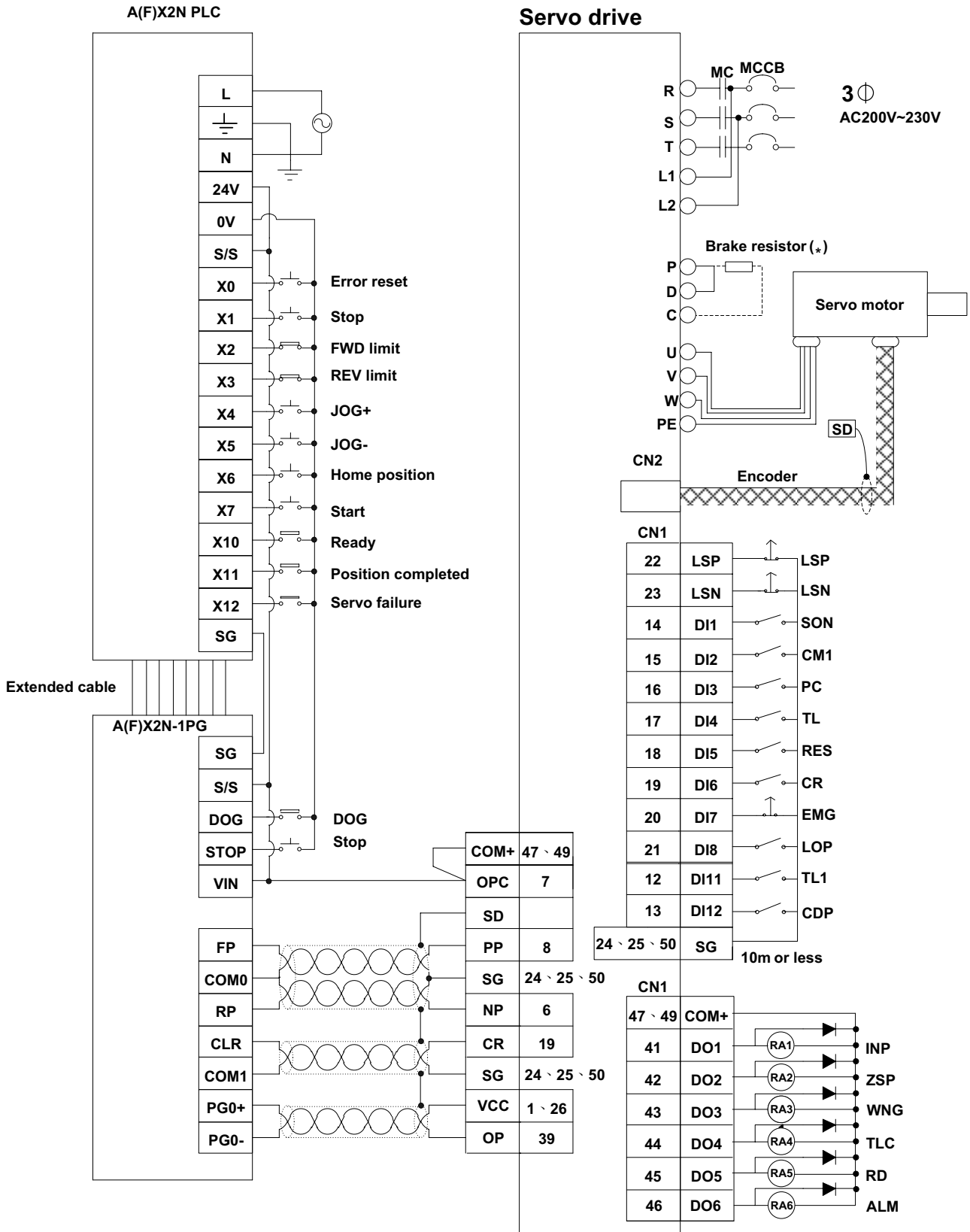

3.8.6 Wiring diagram with 10PG

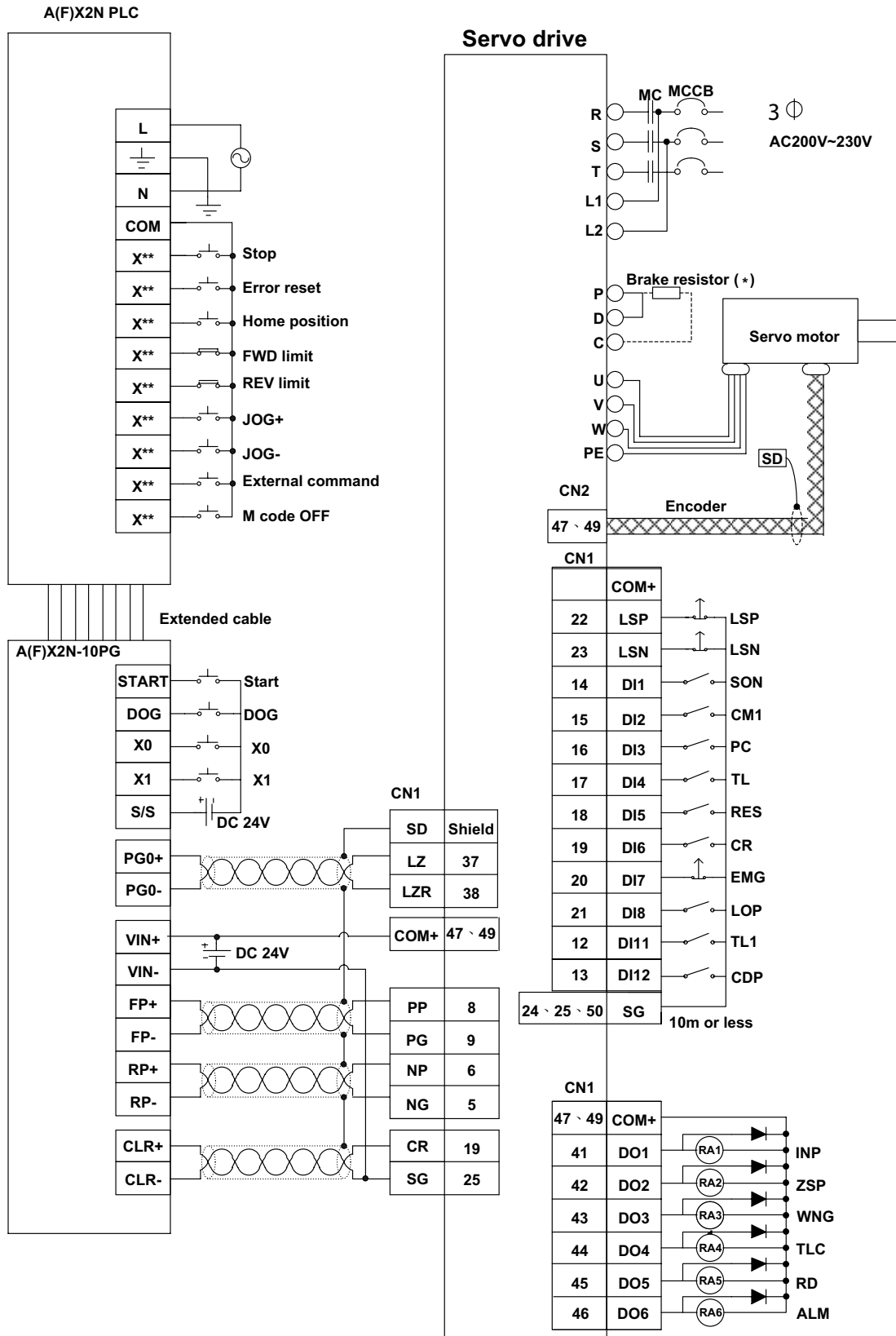

- Note
- 1.If DC24V is from PLC, do not connect +24Vdd and COM+.
 - 2.A(F)X2N-10PG default type is negative logic, forward/reverse rotation pulse train. The PA13 should be set as 0010h.
 - 3.See section 3.1.3 for the wirings of brake resistor.

3.8.7 Wiring diagram with 10GM

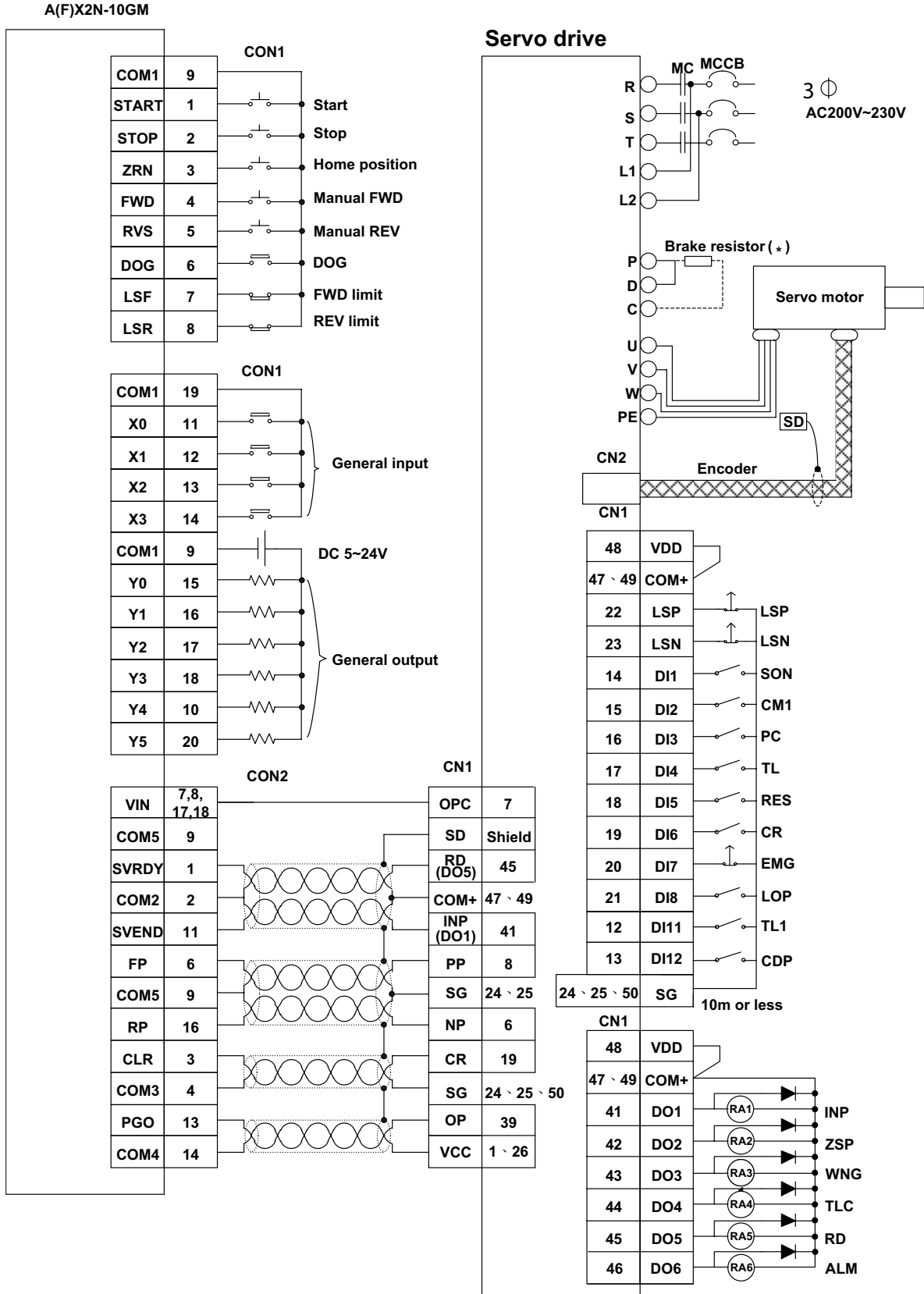

- Note**
- 1.If DC24V is from PLC, do not connect +24Vdd and COM+.
 - 2.A(F)X2N-10GM default type is negative logic, forward/reverse rotation pulse train. The PA13 should be set as 0010h.
 - 3.See section 3.1.3 for the wirings of brake resistor.

3.8.8 Wiring diagram with 20GM

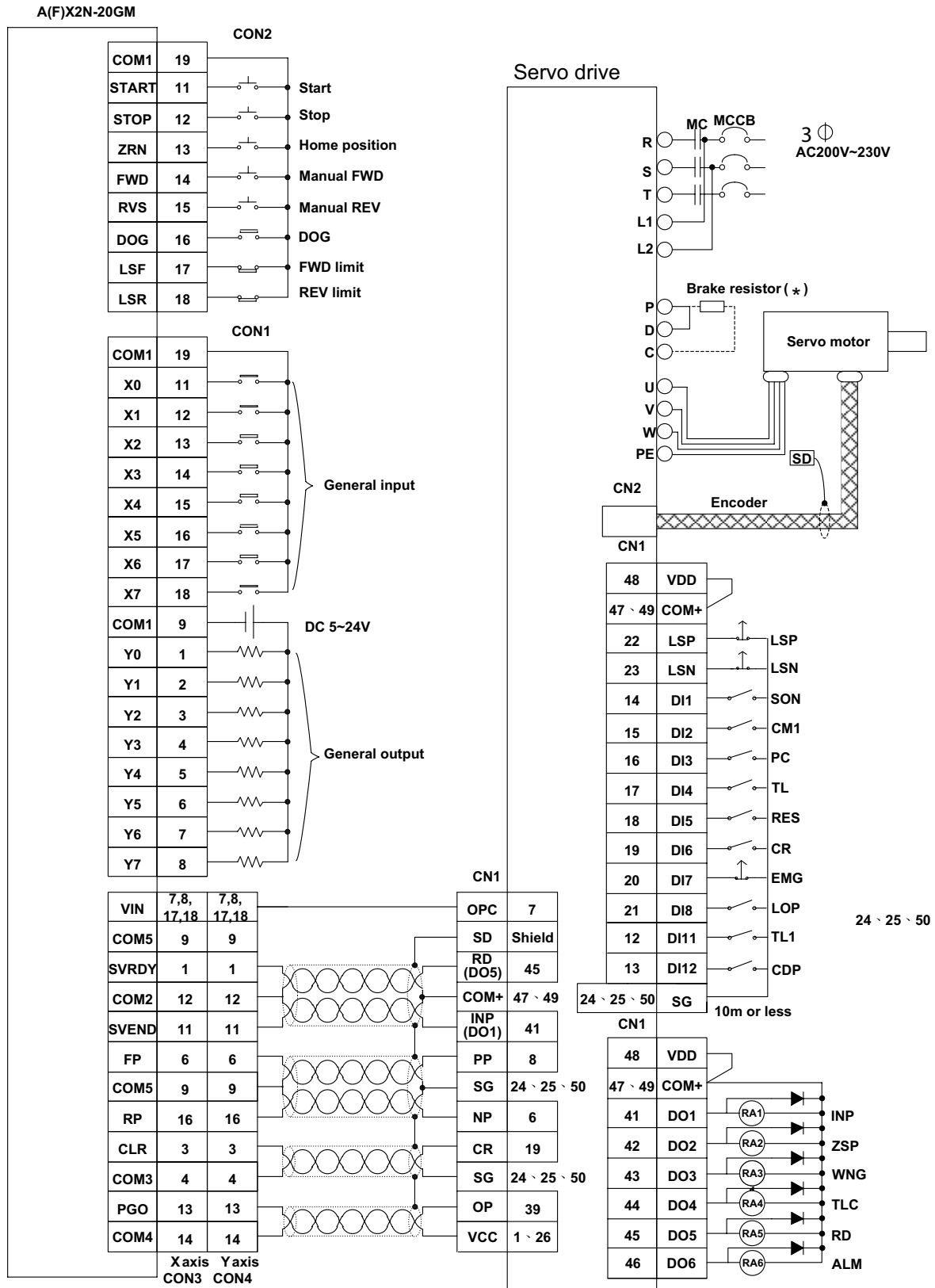

- Note
- 1.If DC24V is from PLC, do not connect +24Vdd and COM+.
 - 2.A(F)X2N-20GM default type is negative logic, forward/reverse rotation pulse train. The PA13 should be set as 0010h.
 - 3.See section 3.1.3 for the wirings of brake resistor.

3.8.9 Wiring diagram with FX3U

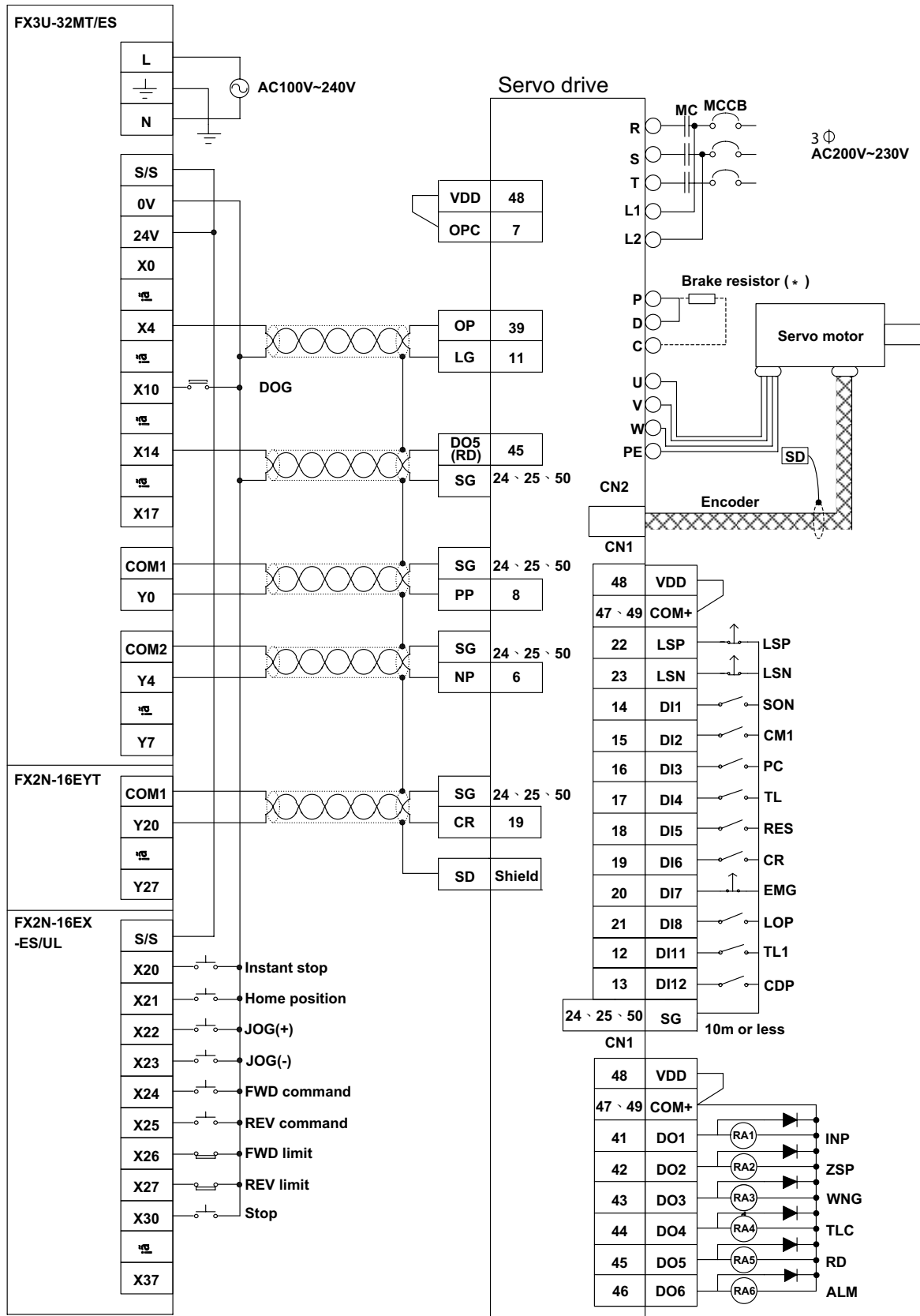

- Note
- 1.If DC24V is from PLC, do not connect +24Vdd and COM+.
 - 2.FX3U-MT default pulse command type is negative logic, pulse train +sign. The PA13 should be set as 0011h. (A(F)X-1N/2N-MT and FX3G-MT are in the same description mentioned above.)
 - 3.See section 3.1.3 for the wirings of brake resistor.

3.8.10 Wiring diagram with QD75

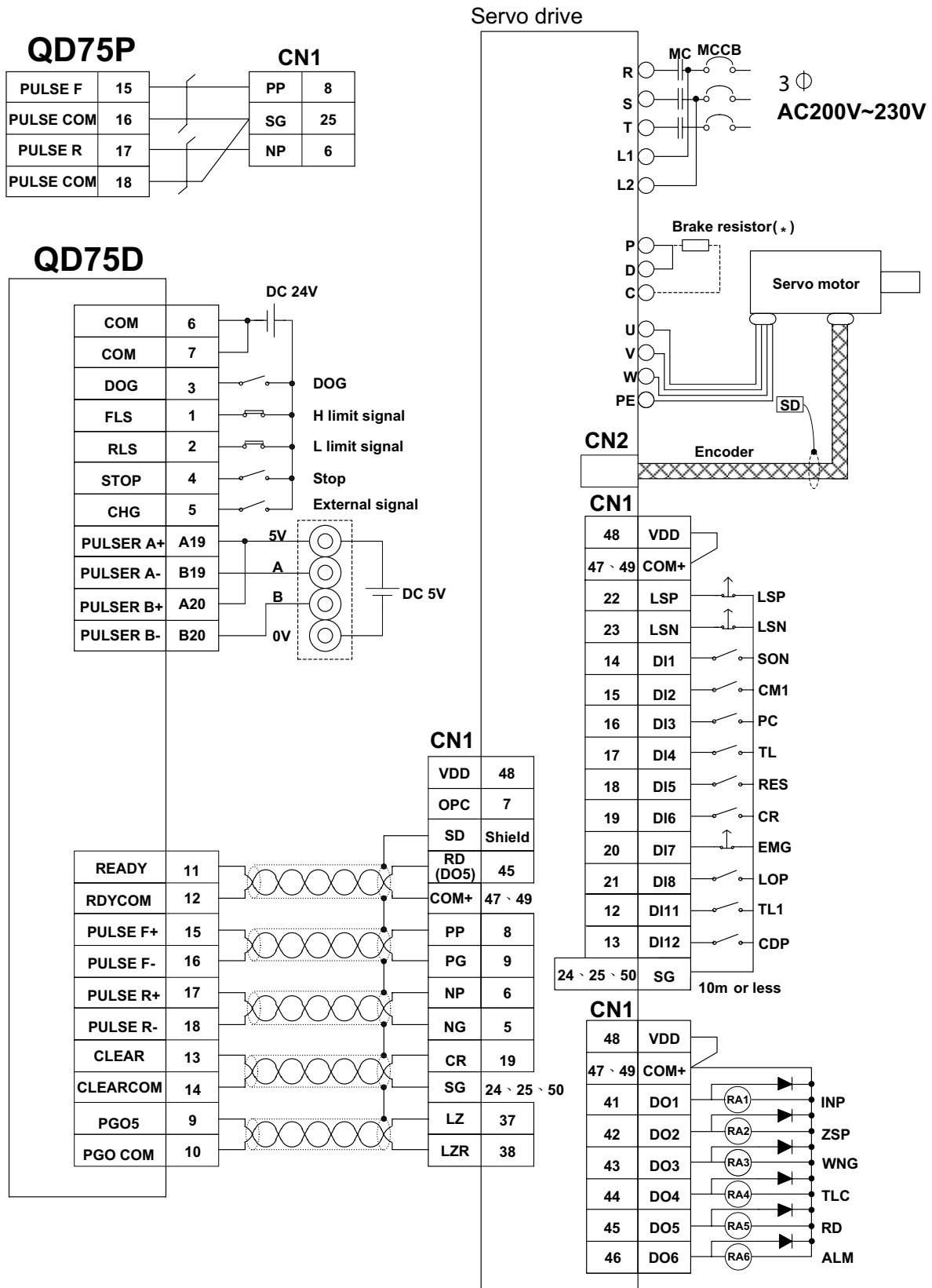

- Note
- 1.If DC24V is from PLC, do not connect +24Vdd and COM+.
 - 2.As QD75D/QD75P default pulse command type is used, The PA13 should be set as 0000h.
 - 3.When QD75D is applied, OPC need to provide DC24V power.
 - 4.See section 3.1.3 for the wirings of brake resistor.

3.8.11 Wiring diagram with Gantry

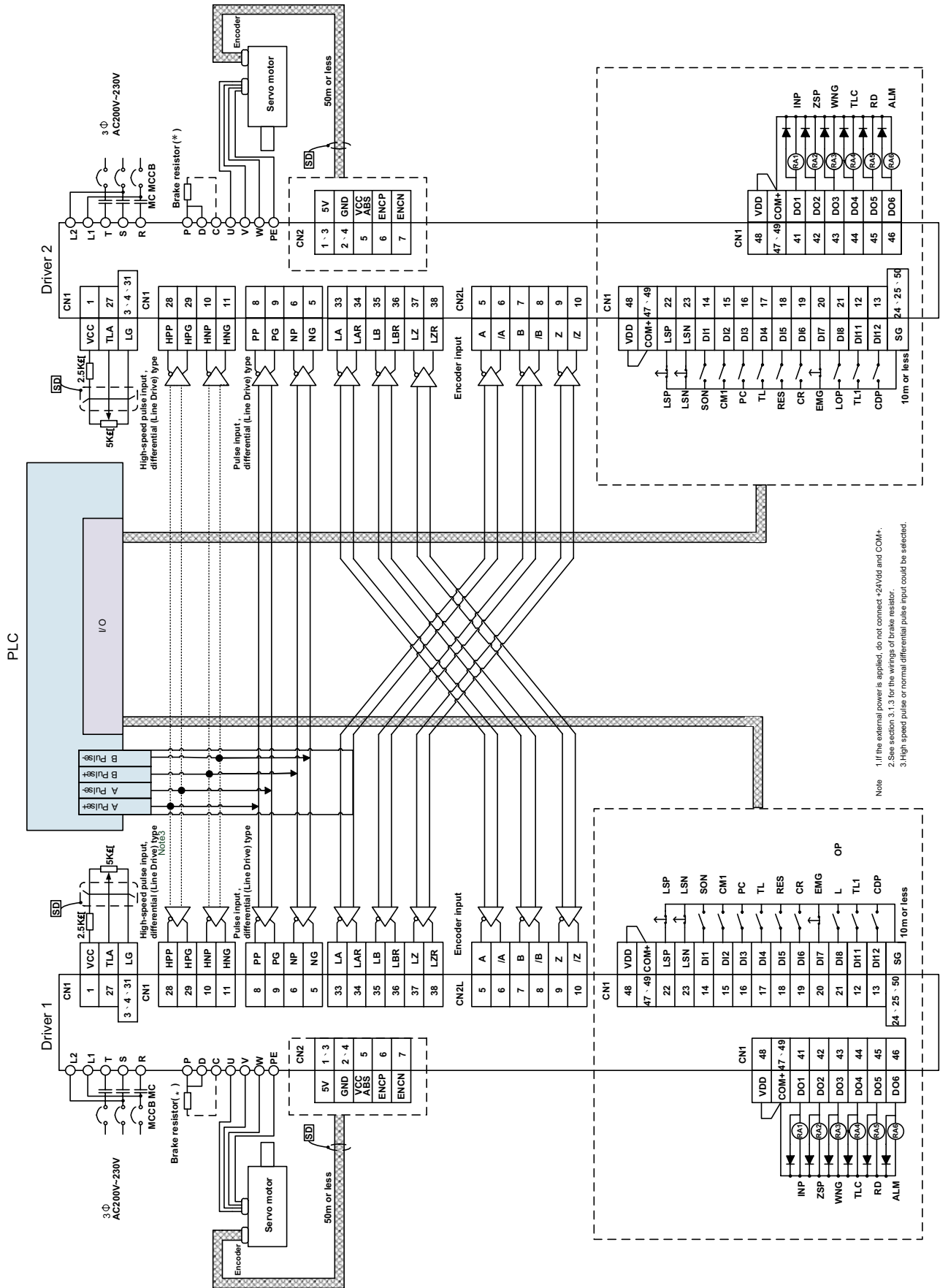

4. Panel display and operation

This chapter describes the conditions of Shihlin servo drive's panel and all operation.

4.1 Panel components

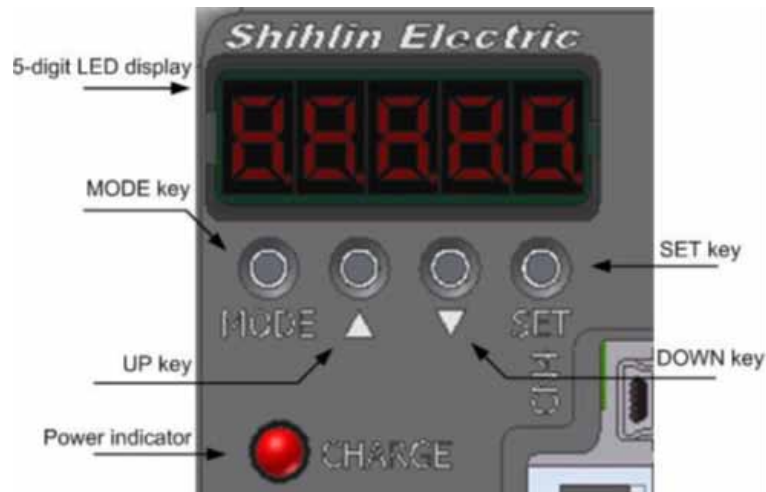

Name	Function description
LED display	This display with 7-segment LED of 5 digits is used to monitor the states of servo and the value of parameters, and set modification value.
MODE key	To switch one display mode to the others. Shihlin servo drive has parameter display mode, alarm history mode, status monitor mode, etc. This button becomes to "Shift" function when in parameter writing-in mode.
UP key	To increase the value which denoted parameter or set value.
DOWN key	To decrease the value which denoted parameter or set value.
SET key	To show or save the value which is operated.
Power indicator	To indicate the power status.

4.2 Display flowchart

Use the display on the front side of servo drive for status display, parameter setting, etc. Set the parameter before operation, diagnose an alarm, confirm external sequences, and confirm the operation status. Press the "MODE" "UP" and "DOWN" buttons once to the next screen. To refer to or set the expansion parameter, make them valid with PA42.

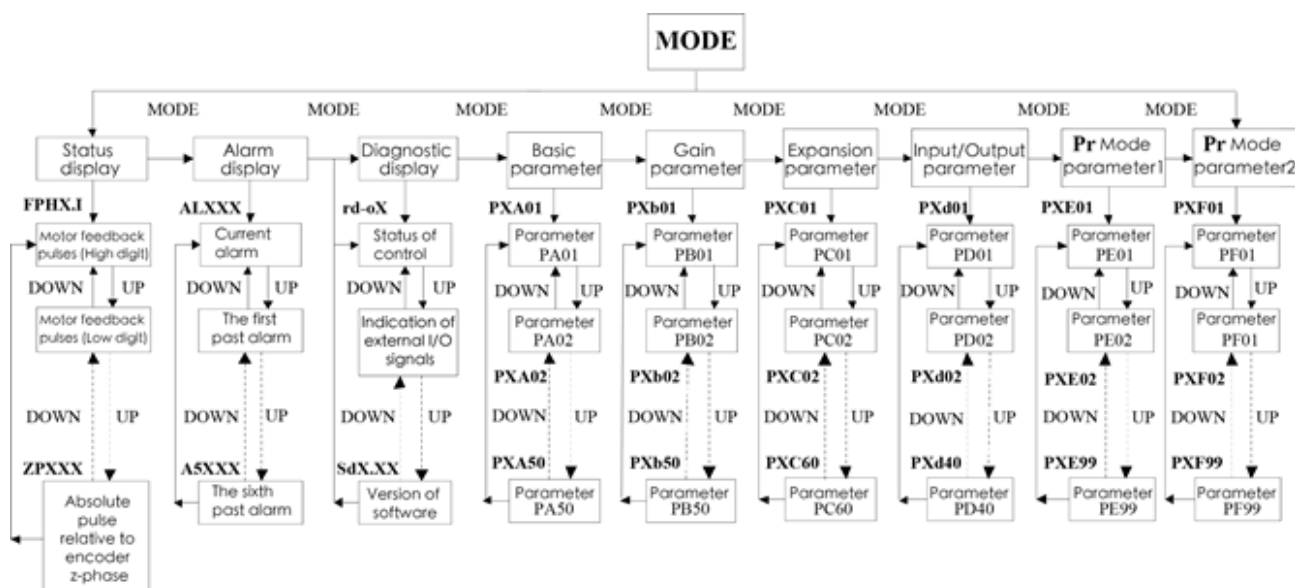

Chart 1: Display flowchart

4.3 Status display

- The operation status of Shihlin servo could be displayed on the 5-digit 7 segment LED display.
- Press the “UP” or “DOWN” key to change the display data as desired.
- When the required data is selected, the corresponding symbol appears. Press the “SET” key to display the information.
- 7 segment LED display could show the 5 digits of 16 items such as motor speed.
- A negative value which occupies 5 digits is displayed by the 5 lit decimal points. If a negative value which occupies only 4 digits or less, the negative symbol “-” is displayed at the highest digit.

Examples

The following table lists the display examples:

Item	Status	Display device
		7 segment LED display.
Motor rotation speed	Forward rotation at 500r/min	
	Reverse rotation at 3000r/min	
The ratio of load inertia to motor shaft	15.5 times	
Motor feedback revolution (high digit)	Value is 1234567890 Display high digit -> 1234.5	
Motor feedback revolution (low digit)	Value is 1234567890 Display low digit -> 67890.	
Parameter setting accomplished	a successful write-in	
Parameter setting failed	Servo on (SON on) a failed write-in	 Please do SON off and write-in again.
Parameter setting over range	Parameter setting over range	 Write-in parameter setting value again

PS: The details of display panel, please refer to the parameter value of section 1.6 for examples

NOTE : When setting the panel parameters, each parameter has the high/low limit values range.
 When the decimal data changes, value has high/low limit.
 When the hexadecimal data changes, Hex value has high/low limit.

List of status display

The servo statuses which may be shown are listed in the following table

Status display	Sign	unit	Description	Range
Motor feedback pulses (High digit) (before electric gear ratio)	FPH.I	pulse	Motor feedback pulses (High digit) (before electric gear ratio) Ex: If feedback pulses are 123456789, than display "1234". Note 1	-21474~21474
Motor feedback pulses (Low digit) (before electric gear ratio)	FPL.I	pulse	Motor feedback pulses (Low digit) (before electric gear ratio) Ex: If pulses are 123456789, than display "56789". Note 1	-99999~99999
Pulse command input pulses (High digit) (before electric gear ratio)	CPH.I	pulse	Pulse command input pulses (High digit) (before electric gear ratio) If command pulses are 123456789, than display "1234". Note 1	-21474~21474
Pulse command input pulses (Low digit) (before electric gear ratio)	CPL.I	pulse	Pulse command input pulses (Low digit) (before electric gear ratio) If command pulses are 123456789, than display "56789". Note 1	-99999~99999
Accumulative pulses error (before electric gear ratio)	E. I	pulse	Accumulative pulses error (before electric gear ratio) Because the display shows only 5 digits, it represents the actual number of 5 digits.	-99999~99999
Motor feedback pulses (High digit) (after electric gear ratio)	FPH.O	pulse	Motor feedback pulses (High digit) (after electric gear ratio) Ex: If feedback pulses are 123456789, than display "1234". Note 1	-21474~21474
Motor feedback pulses (Low digit) (after electric gear ratio)	FPL.O	pulse	Motor feedback pulses (Low digit) (after electric gear ratio) Ex: If pulses are 123456789, than display "56789". Note 1	-99999~99999
Pulse command input pulses (High digit) (after electric gear ratio)	CPH. O	pulse	Pulse command input pulses (High digit) (after electric gear ratio) If command pulses are 123456789, than display "1234". Note 1	-2147~21474
Pulse command input pulses (Low digit) (after electric gear ratio)	CPL.O	pulse	Pulse command input pulses (Low digit) (after electric gear ratio) If command pulses are 123456789, than display "56789". Note1	-99999~99999
Accumulative pulses error (after electric gear ratio)	E. O	pulse	Accumulative pulses error (after electric gear ratio) Because the display shows only 5 digits, it represents the actual number of 5 digits.	-99999~99999
Command pulse frequency	CPF	kHz	The frequency of external command pulse is displayed.	-6000~ 6000
Motor speed	r	rpm	The speed of servo motor is displayed.	-6000~ 6000
Speed analog command /limit voltage	F	V	Speed control mode: Speed analog command voltage is displayed. Torque control mode: Speed analog limit voltage is displayed.	-10.00~ +10.00
Speed input command/limit	V	rpm	Speed control mode: Speed input command is displayed. Torque control mode: Speed input limit is displayed.	-6000~ 6000
Torque analog command /limit voltage	U	V	Position control mode, speed control mode: Torque analog limit voltage (TLA) is displayed. Torque control mode: Torque analog command voltage is displayed.	0 ~ +10.00 -10.00~ 10.00

Torque input command/limit	TC	%	Position control mode, speed control mode: Torque input limit is displayed in percentage.	0~ 300
			(2) Torque control mode: Torque command is displayed in percentage.	-300~300
Effective load ratio	J	%	The continuous and effective load torque is displayed relative to the rated torque of 100%.	0~ 300
Peak load ratio	b	%	The highest value in the past 15 seconds is displayed relative to the rated torque of 100%.	0~ 300
DC bus voltage	Pn	V	The P-N voltage of main circuit is displayed. "Lo-dC" is shown if it less than normal value.	0~500
The ratio of load inertia to motor shaft	dC	times	The ratio of load inertia to motor shaft is displayed.	0.0~300.0
Instantaneous torque	T	%	The Instantaneous torque value is displayed relative to the rated torque of 100%.	0~100
Regenerative load rate	L	%	The current allowable regenerative power ratio displayed in percentage.	0~100
Fully closed encoder feedback pluses (High digit) (after electric gear ratio)	FFH	pulse	Fully closed encoder feedback pluses (High digit) Ex: If feedback pluses are 123456789, than display "1234".	-21474~21474
Fully closed encoder feedback pluses (Low digit) (after electric gear ratio)	FFL	pulse	Fully closed encoder feedback pluses (Low digit) Ex: If pluses are 23456789, than display "56789".	-99999~99999
Fully closed command pluses (High digit)(after electric gear ratio)	FCH	pulse	Fully closed command pluses (High digit) Ex: If pluses are 123456789, than display "1234".	-21474~21474
Fully closed command pluses (Low digit)(after electric gear ratio)	FCL	pulse	Fully closed command pluses (Low digit) Ex: If pluses are 123456789, than display "56789".	-99999~99999
Absolute pulse relative to encoder z-phase	ZP	pulse	Absolute pulse relative to z-phase of encoder means that the origin value of Z phase is 0 and could be form positive 5000 to negative 5000 pulse, The drawing shown below.	-4999 ~ 5000

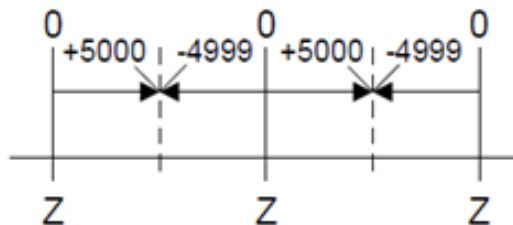

Note1: When the panel display value data screen, press the "SET" key to clear pulse number, command input errors, motor feedback pulse, pulse error before the electronic gear ratio and after the electronic gear ratio. This action definition has the same content with communication address 0x0951.

Changing the status display screen









Changing the parameter PA01, the status item of the servo drive at power on could be changed. The item displayed in the initial status changes with the control mode as follows:

Control mode	Status display
Position	Motor feedback pulses (low digit)
Position/speed	Motor feedback pulses (low digit) / Motor speed
Speed	Motor speed
Speed/torque	Motor speed / Torque analog command voltage
Torque	Torque analog command voltage
Torque/position	Torque analog command voltage / Motor feedback pulses (low digit)

4.4 Alarm display

It displays the current alarm and the alarm history record.

The lower two digits display the abnormal alarm number which has occurred.



Name	Display	Description
Current alarm		No alarm occurred.
		Over voltage occurred(AL 01), The screen flickers synchronously.
Alarm history		Indicates that the last alarm is over voltage(AL 01)
		Indicates that the 2nd alarm in the past is low voltage (AL 02)
		Indicates that the 3rd alarm in the past is over current(AL 03)
		Indicates that the 4th alarm in the past is regenerative error (AL 04)
		Indicates that the 5th alarm in the past is over load (AL 05)
		Indicates that the 6th alarm in the past is over speed (AL 06)

Functions when abnormal alarm occurred:

- A. Any mode screen could display the current alarm.
- B. The other screen could be read during the occurrence of an alarm.
- C. Remove the cause of the alarm and clear it by one of the following methods:
 - (a) Switch the power OFF, then ON.
 - (b) Press the "SET" key on the current alarm screen.
 - (c) Turn on the abnormal alarm reset signal (RES).
- D. Move to the next record by pressing "UP" or "DOWN".

4.5 Diagnostic display

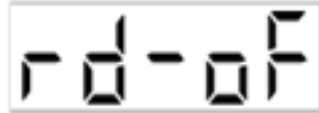
The following table provides information related to the operation of diagnostic display:

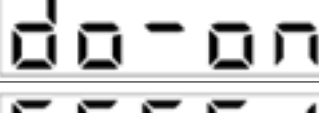
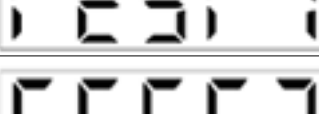
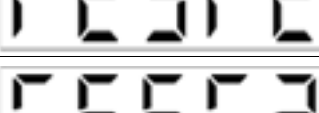
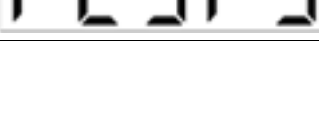
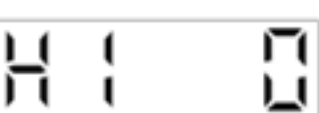
Name	Display	Description
Control status		Not ready yet. The drive is being initialized, an alarm has occurred or SON pin is OFF
		Ready. Initialization completed; ready for operation.
External I/O signal display		Indicates the ON/OFF states of the external I/O signals. The upper segments correspond to the input signals and the lower ones to the output signals. The I/O signals could be changed by the modification of PD group.
Output signal forced output		Digital output signals could force ON/OFF. For more information, refer to Section 4.5.2.
JOG Test mode		JOG test could be executed as no command from the external command device. For details, refer to section 5.2.1.
Positioning test mode		Positioning test could be executed once when there is no command from the external command device. The PC communication software via RS-232/USB is required This operation could not be performed from the display panel.
Inertia estimation mode		This operation could execute the estimation ratio of the motor shaft to the load or related gain values. The PC communication software via RS-232/USB is required This operation cannot be performed from the display panel.
Automatic offset of analog input		If offset voltages in the analog circuits inside and outside the drive cause the motor to rotate slowly at the speed analog command or speed analog limit of 0V, this function automatically makes zero-adjustment of offset voltages. When using this function, the parameter PC26 would be automatically adjusted to the offset voltage. Please follow the steps to operate: Switch to automatic offset of analog input panel Press the "SET" key once. Press the "UP" or "DOWN" key and select 1. Press the "SET" key.
Software version		Indicates the software version of the drive

The applications of diagnostic display are described below:

4.5.1 Indication of external I/O signals

This display is used to verify the ON/OFF states of digital I/O signals connected to the drive

(1) Operation

Call the display screen after power on. Press the "MODE" key to show the diagnostic screen:

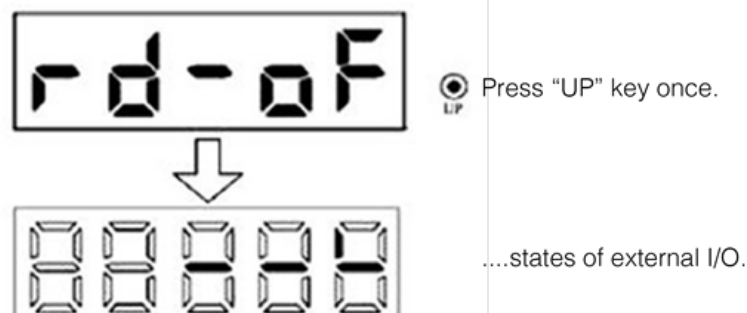

(2) The display of I/O pin definition

Suitable for 7-segment LED position and PIN.

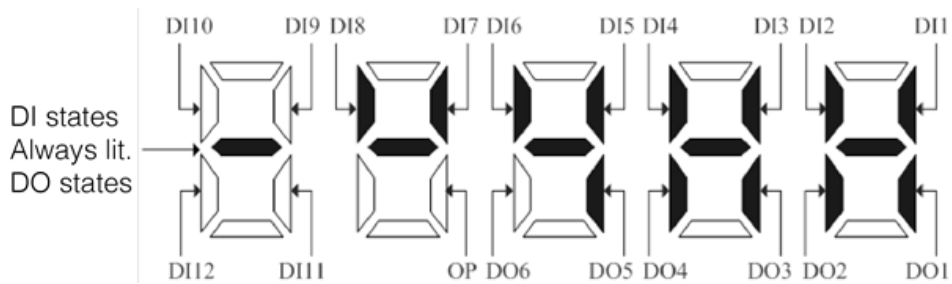

The 7-segment LED shown above indicates the ON/OFF states of DI and DO.

The top segments indicate the input signals (DI1~DI10) which are ON and the bottom segments indicate the output signal (DO1~DO6、OP) and input signals DI11、DI12. Take above picture as an example, DI1 ~ DI8 are ON; DI9 ~ DI12 are OFF; DO1 ~ DO5 are ON, DO6, OP are OFF.

4.5.2 The output signals forced output (DO forced output)

The output signals could be forced on/off and do not affect the status of the servo drive. This function is used for output signal wiring check, etc.

As neither external command nor any alarm occurred, DO forced output operation could be executed. Do not execute this operation until the contact between SON and SG is open.

Operation

Call the display screen after power on. Press the “MODE” key to show the diagnostic screen:

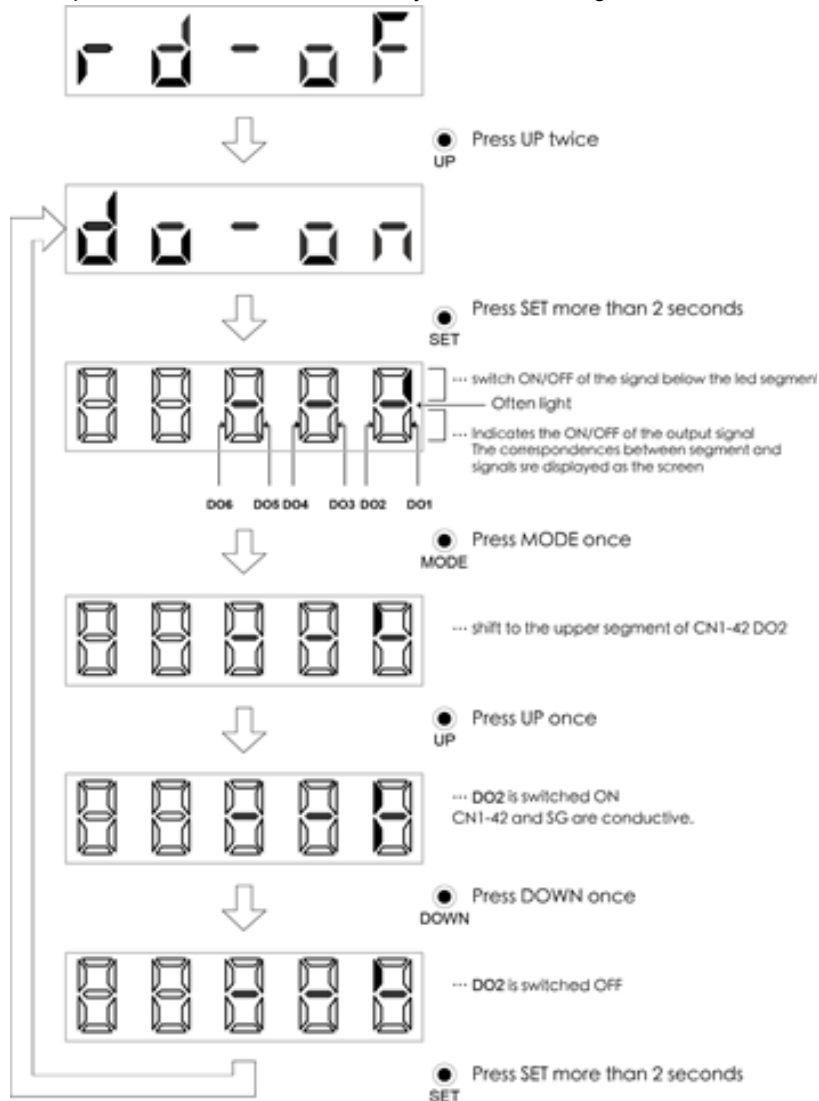

4.5.3 JOG test mode

As neither external command nor any alarm occurred, JOG test could be executed. Do not execute this operation until the contact between SON and SG is open.

Set the speed command of JOG by the PC04, set the acceleration time by the PC01, and set the deceleration time by the PC02. Call the display screen after power on, select JOG test, positioning test and approximate inertia operation by the following steps:

Press the MODE key to go to the diagnostic screen.

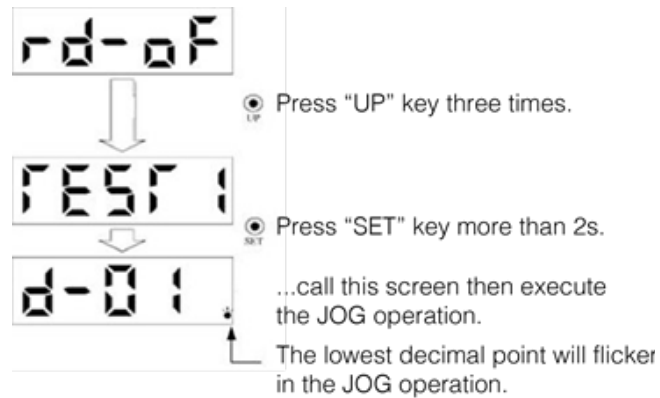

(1) Operation

As the JOG test is executed, please make Vdd and COM+ short circuit if the inner power is applied on EMG-SG. Press the "UP" or "DOWN" key to run the motor. Release the key to stop. Use the communication software to change the operation conditions. The initial conditions and setting ranges for the operation are presented below:

Item	Initial setting	Setting value	Setting range
Rotary speed[r/min]	PC04	300	-4500~4500
Acceleration/deceleration time constant	PC01 · PC02	200	0~20000

NOTE : JOG speed on panel is settled by parameter PC04, if operate JOG function by using communication software, the speed setting value is determined by other communication address.

Key functions are described as follows:

Key	Description
"UP"	Press to run CCW rotation. Release to stop.
"DOWN"	Press to run CW rotation. Release to stop.

If the communication cable is disconnected during JOG test by using the communication software, the servo motor will be decelerated to a stop.

(2) Status display

Users could check the servo status during JOG test.

Press the "MODE" key to show the status display during the ready of JOG test. Perform the JOG test in this status screen with "UP" and "DOWN" keys. Each press of "MODE" key will show the next status screen. After an entire cycle, the ready of JOG test is returned. More details related to the status display could be found in Section 4.3.

There is no use to press "UP" and "DOWN" buttons to change the status screen in JOG operation mode.

(3) JOG test completed

Turn off the power or press the "SET" key in operation test mode for more than 2 seconds to terminate the JOG test.



4.5.4 Positioning test

Shihlin communication software which needs to be connected by RS-232 or USB is required to execute the positioning test. As no external command nor any alarm occurred, positioning test could be executed. Before this operation, make sure that the contact between SON and SG is open.

Operation

Make sure that the motor is correctly wired before this test performed. Select operation testing via Shihlin communication software. Press "Forward" or "Reverse" to rotate the motor which will then stop after moving the command route set by the user. Operation conditions could be modified with Shihlin communication software. The initial values and setting ranges are listed in the table below:

Name	Initial value	Setting range
Rotary speed (rpm)	200	0~6000
Acceleration/deceleration time constant (ms)	1000	0~20000
Revolution (10kpulse)	10	0~30000
pulse (pulse)	0	0~9999

Description of the buttons :

Button name	Function description
Forward	Press to run positioning test in CCW.
Reverse	Press to run positioning test in CW.
Pause	Press "Pause" button during operation to make a temporary stop. To press the same button which was pressed to finish the remaining route. Otherwise, to press "Pause" button again to erases the remaining route.
Close	Terminate this test.

The motor will stop immediately if the communication cable is disconnected during operation.
The panel display like the following picture when the software becomes to position test mode.



...When this screen appears, JOG test can be performed.

↑ Flickers in the tset operation mode.

4.5.5 Automatic offset of analog command input

When the external speed analog command input is 0V, there may be still an offset voltage which will cause a slow motor rotation inside the servo drive. The user could “erase” this bias with the automatic offset function in the diagnostic display mode. Follow the steps to execute automatic offset operation of analog input:

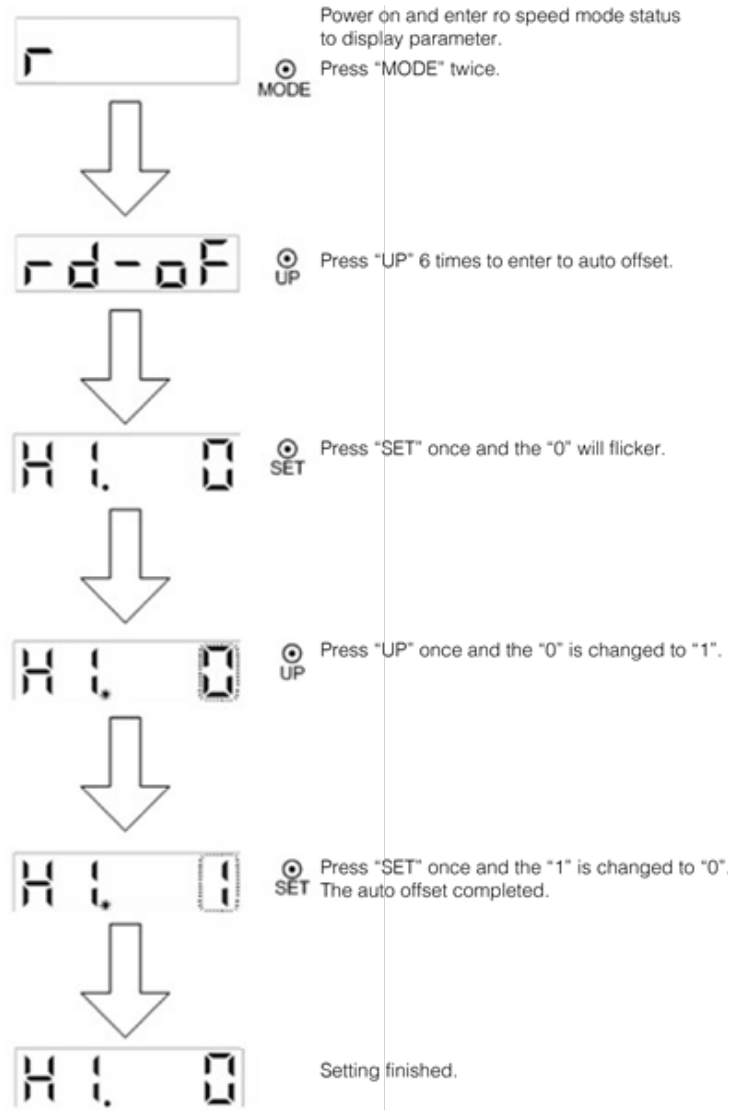

After the automatic offset completed, the bias value will be written into the PC26.

4.5.6 Inertia estimation

Shihlin communication software which needs to be connected by RS-232 or USB is required to execute the positioning test. As no external command nor any alarm occurred, positioning test could be executed.

Operation

Make sure that the motor is wired correctly before operating this inertia estimation. Under Shihlin communication window, choose the “auto gain tuning” item.

Inertia estimation operation method:

- Select the “Auto tuning control panel”.
- The acceleration/deceleration time constant, S type acceleration/deceleration time constant and JOG speed could be set in no alarm situation by pressing the “Set” button.
- Press the “Servo ON” button and then the motor would be magnetized
- Press the “JOG” left or right button to control the motor in CCW or CW and to the position, set position 1, then press the “JOG” button, set the position 2.
- When position 1 and 2 setting finished press “start” button to run estimate inertia and gain operation.
- When the response is not enough, you can set response at operation menu directly, but don't set the response value too high instantly, please increase step by step.
- After the values getting more stable or customers were satisfied with the machine characteristics, press the “Stop” button to finish estimate inertia and gain operation.
- Cancel the auto gain control panel options.

During the acceleration or deceleration process, the servo drive would calculate the ratio of load inertia to motor shaft and the bandwidth of the system. The relevant parameters are listed below:

Name	Abbr.	Sign	Setting range	Unit	Initial value	Control mode
Resonance suppression low-pass filter	NLP	PB03	0~10000	0.1ms	10	Pt、Pr、S、T
Position feed-forward gain	FFC	PB 05	0~200	%	0	Pt、Pr
The ratio of load inertia to motor shaft	GD1	PB 06	0~1200	0.1time	70	Pt、Pr、S
Position loop gain	PG1	PB07	4~1024	rad/s	45	Pt、Pr
Speed loop gain	VG1	PB08	40~9000	rad/s	183	Pt、Pr、S
Speed integral gain	VIC	PB 09	1~1000	ms	34	Pt、Pr、S

The panel display like the following picture when the software becomes to inertia estimation mode.

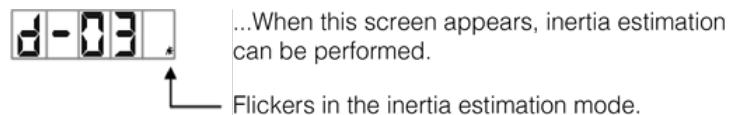

4.6 Parameter display

4.6.1 16bit parameter setting method

Some parameter modification would be valid by power off once and power on again.

Operation method

Here is an example. This is the operation method of changing the control mode (PA01) to speed control mode after power off and power on again.

Example: Change the control mode (PA01) to the speed control mode.

Use the “MODE” key to switch to the “PA 01” parameter menu.

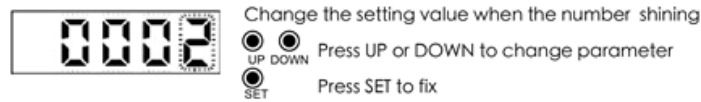
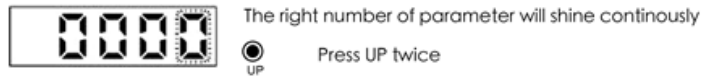

Press the "UP DOWN" button to the next parameter.

When changing the parameter PH 01, it is required to restart the power after changing the value to complete this setting. Switch the usage of "MODE" key to the "shift" function when parameter setting. The Use of "MODE" button and "UP", "DOWN" button will be described in the next section

4.6.2 32bit parameter setting method

Decimal parameter display data (Positive value)

Example : PA19 = 1234567, change the parameter to 1434567, the setting method show below.

	SET Press "SET" once. Low byte indication. The fifth led digits represent low byte.
	MODE Press "MODE" once. High byte indication. The forth led digits represent high byte.
	MODE Press "MODE" once. Return to low byte indication.
	SET Press "SET" once. ...The set value of the specified parameter number flickers. Press UP or DOWN to change the number.
	MODE Press "MODE" 5 times. ...The set value of the specified parameter number flickers. UP Press "UP" twice.
	SET Press "SET" once to enter parameter.

Decimal parameter display data (Negative value)

Example: PA19 = 1234567 and change the parameter to -1234567, the setting method show below.



The data of PA17 is 1234567.

⊙
SET

Press "SET" once.
Low byte indication.
The fifth led digits represent low byte.



⊙
MODE

Press "MODE" once.
High byte indication.
The forth led digits represent high byte.



⊙
SET

Press "SET" once.
...The set value of the specified parameter number flickers.



⊙
MODE

Press "MODE" twice.



⊙
SET

Press "SET" once.
High byte displays-12.



⊙
MODE

Press "MODE" once.
Low byte represents 34567.
The most left two LED digits represent negative sign.



⊙
UP

Press "UP" once.
Return to PA group.



Hexadecimal parameter display data

Example: PE01 = 0x03760135, and change the parameter to 0x03740135, the setting method show below.



⊙ Press "SET" once.
SET

Hex low indication.
The most left bottom line represents low byte.



⊙ Press "MODE" once.
MODE

Hex high indication.
The most left upper line represents high byte.



⊙ Press "MODE" once.
MODE

Return to low byte indication.



⊙ Press "SET" once.
SET

...The set value of the specified parameter number flickers.
PressUP or DOWN to change the number.



⊙ Press "MODE" 4 times.
MODE







⊙ Press "DOWN" twice.
DOWN

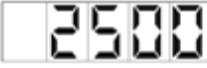

⊙ Press "SET" once to enter parameter.
SET

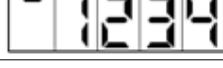
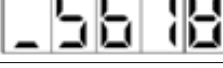
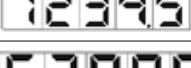
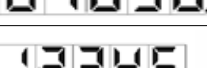
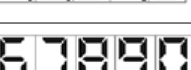
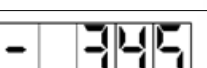
Parameter data display example

Item	Description	Display
		7-segment LED
16 bit data	Hexadecimal display If the value is 0x1234, the display is 1234.	 (Hex)
	Decimal Positive value display If the value is 2500, the display is 2500	 (Positive Dec)
	Decimal Negative value display If the value is -12566, the display is 1.2.5.6.6.	 (Negative Dec)
32 bit data	Hexadecimal display If the value is 0x12345678, the display is 1234 at high byte; the display is 5678 at low byte.	 (HEX high)
		 (HEX low)
	Decimal Positive value display If the value is 1234567890, the display is 1234.5 at high byte; the display is 67890 at low byte.	 (Positive Dec high)
		 (Positive Dec low)
	Decimal Negative value display (1) If the value is -1234567890, the display is 1.2.34.5 at high byte; The display is 6.7.890 at low byte.	 (Negative Dec high)
		 (Negative Dec low)
	Decimal Negative value display (2) If the value is -34567890, the display is -34.5 at high byte; The display is 6.7.890 at low byte.	 (Negative Dec high)
		 (Negative Dec low)

Note 1: Dec means Decimal, He means Hexadecimal.

Note 2: Hexadecimal has no positive or negative display.

5. Operation

5.1 Checklist before operation

To avoid the damage, before starting the operation, please check the following

- Whether the power source terminals (R, S, T, L1, and L2) of the servo drive are correctly wired.
- The terminals (U, V, W) of the motor and the U, V, W wires on the drive need to be consistency.
- Make sure if the ground terminal of the servo drive is correctly grounded.
- Make sure there are no conductive or inflammable materials inside the drive or close to the drive.
- Make sure the voltage level of external power source of the drive is proper.
- Make sure that the control switch is off.
- Do not put heavy objects on top of the drive or the wire
- Use twisted line for the wiring of the brake resistor.
- Check if there is any apparent damage on the exterior of the drive.

CAUTION • Operate the power switches with dry hand to prevent an electric shock.

WARNING • Before trial run, check if the parameters are set properly. Otherwise it will cause some unexpected operation.
• Don't touch either the drive heat sink or the motor during operation because they may become hot and cause personnel burnt.

5.2 Idle operation

Please decouple the load (e.g., any coupler between the servo motor shaft and user's machine) before an idle operation. To follow the regular instruction to start the servo motor and then couple the servo motor with user's machine again. The idle operation is explained as below.

5.2.1 Idle JOG test

- This operation could be performed only if there is neither alarm nor warning on the drive.
- To confirm an open contact between SON and SG before this operation.

The idle JOG test could be executed with the drive's panel or Shihlin communication software in order to check if the speed and direction of the motor is as expected or not. The motor speed could not be modified with the drive's panel. If the rotation speed has to be modified, please use Shihlin communication software which is connected by RS-232 or USB to modify. The low speed command is recommended when this operation performed. The panel operation is described as follows:

Step 1. Wire the drive and the motor correctly then turn on the power.

Step 2. Press the "MODE" button to call the diagnostic screen then press "UP" key three times to TEST1 (JOG Mode) and press "SET" key more than 2 seconds to d-01 screen(JOG operation).

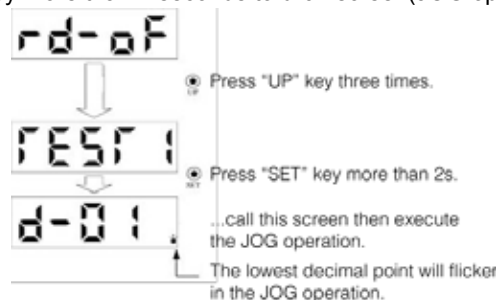

Step 3. Press the "UP" key to run the motor in CCW or the "DOWN" key to run the motor in CW and release to stop. Use communications software to change operating conditions.

The initial conditions and setting ranges are presented below:

Item	Initial setting	Setting range
Rotary speed [r/min]	300	-4500~4500
Acceleration/deceleration time constant	200	0~20000

If the communication cable is disconnected during this operation with the communication software, the motor will be decelerated to a stop. Button functions are described as follows:

Button name	Description
“Forward”	Press to run CCW rotation.
“Reverse”	Press to run CW rotation.
“Stop”	Press “to make the motor stop.
“Close”	Terminate the positioning test.

Step 4. To terminate the idle JOG test, turn off the power or press the “SET” key more than 2 seconds in the display of “d-01” screen.



- If Shihlin communication software is applied to perform the idle JOG test, please refer to the instruction of the help file for more detail.

5.2.2 Idle positioning test

The idle positioning test could be executed with Shihlin communication software connected by RS-232 or USB to check if the speed and direction of the motor is as expected. The low speed command is recommended when this operation is performed. The route which is composing of revolutions and pulses should be set for this positioning test. For example, the motor rotation 1 turn needs 22-bit pulse (4194304 pulses) and a route of 10.5 turns for the servo motor, the number of pulse should be set as “44040192” pulses. The operation steps are described below:

Step 1. Wire the drive and the motor correctly then turn on the power.

Step 2. Connect the PC and the CN4 port of the drive with the standard mini USB cable. Execute the USB communication function of Shihlin communication software and select the proper device number.

Step 3. Select “TESTING/POSITIONING TESTING” to enter positioning test screen.

Step 4. Set the numbers of revolution and pulse. Press “Forward” to run the motor CCW to complete the distance. Or press “Reverse” to run the motor CW to reach the target position. The initial conditions and setting range are listed below:

Item	Initial setting	Setting range
Offset pulse	0	0~2147483647
Rotary speed [r/min]	200	0~ to the max allowable speed
Acceleration/deceleration time constant	1000	0~20000

Description of the buttons:

Button name	Description
“UP”	Press to run positioning test in CCW to reach target revolutions and pulses.
“DOWN”	Press to run positioning test in CW to reach target revolutions and pulses.
“Pause”	Press “Pause” button during operation to make a temporary stop. To press the same button which was pressed to finish the remaining route. Otherwise, to press “Pause” button again to erases the remaining route.
“Close”	Terminate the positioning test.

Step 5. When the positioning test is completed, press “Close” to return the last window of Shihlin communication software.

5.3 Tuning process

CAUTION • Please do not adjust and change parameters extremely which will cause device instability.

5.3.1 Abstract

With the auto-gain tuning function, the mechanical load inertia could be approximated precisely. The appropriate gain value of controller parameter also could be fitted for the servo motor under the various load conditions. The manual tuning function is executed as the result of auto-gain tuning function is not suitable for the user's mechanical system.

Gain tuning mode is explained in the following table:

Gain tuning mode	PA 02 setting	Estimation rule	Automatically set parameter	Manually set parameter
Manual gain tuning mode (PI control)	0000 0001	A fixed PB06.		GD1(PB 06) PG1 (PB 07) VG1 (PB 08) VIC (PB 09)
Auto-gain tuning mode 1	0002	Always estimated.	GD1(PB 06) PG1 (PB 07) VG1 (PB 08) VIC (PB 09)	ATUL(PA 03)
Auto-gain tuning mode 2	0003	A fixed PB06.	PG1 (PB 07) VG1 (PB 08) VIC (PB 09)	ATUL(PA 03) GD1(PB 06)

- The PA02 is not writable as SON-SG is conductive. Make it open circuit then setting the values.

Follow the steps listed below to tune the proper gain value of user's mechanical application.

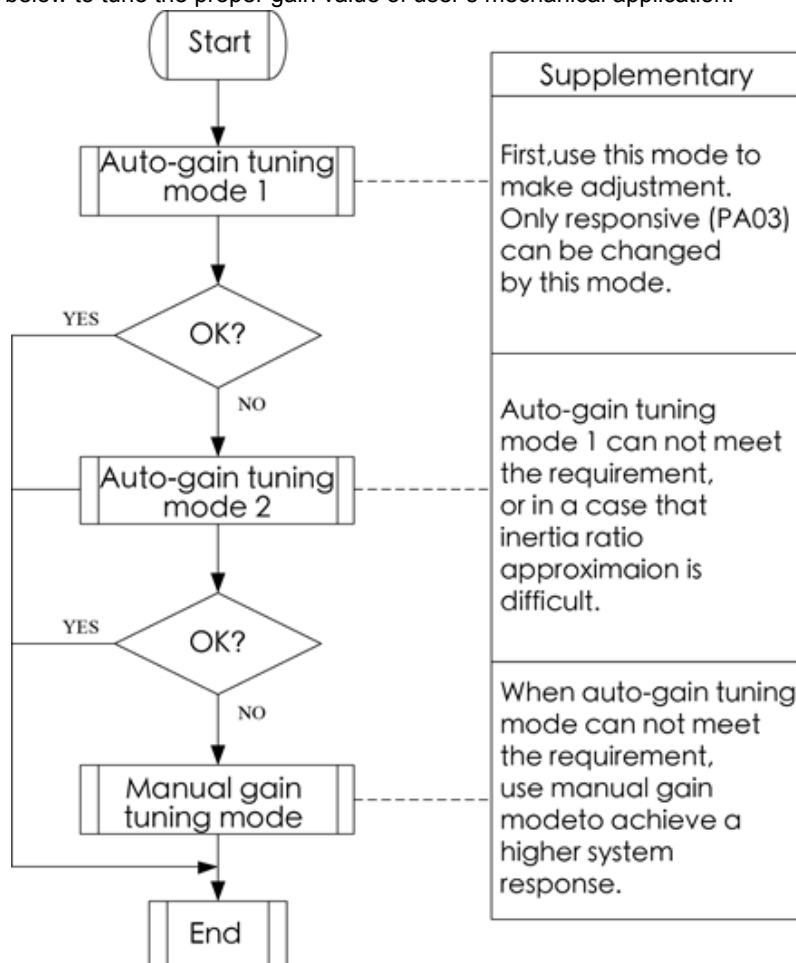

If the mechanical system which being tuned is a new set up, please use the JOG test at first. As no abnormal alarm occurred then use the auto-gain tuning function. During the auto-gain tuning function operated, several routes of acceleration and deceleration are necessary to make the ratio of load inertia to motor shaft be getting stable. Finally, the proper gain and response would be set.

5.3.2 Auto-gain tuning mode

The auto-gain tuning of the drive could calculate the ratio of load inertia to motor shaft instantaneously. With this value, the optimum gain could be decided under the current mechanical condition. It is convenient to execute the adjustment of gain value with the auto-gain tuning function.

5.3.2.1 Auto-gain tuning function

(1) Auto-gain tuning mode1

This mode is the default mode of the servo drive. If the parameter PA02 is set as "0002h", the load inertia ratio would be approximated continuously and the servo gain value will be set automatically. The variable parameter for users is only PA03 which the response setting related.

Parameters and settings related of this mode are presented below:

Parameter NO	Abbr	Parameter name	User adjustable or auto-presumed
PA 03	ATUL	Auto-tuning response level setting	User adjustable
PB 06	GD1	The ratio of load inertia to motor shaft	auto-approximated
PB 07	PG1	Position loop gain	auto-approximated
PB 08	VG1	Speed loop gain	auto-approximated
PB 09	VIC	Speed integral gain	auto-approximated

When the function of auto-gain tuning mode 1 is applied, some conditions must be met.

- The acceleration time from 0rpm to 2000rpm or the deceleration time from 2000rpm to 0rpm should be 2 second or less. If a 3000rpm case is applied, the acceleration and deceleration time should be 3 seconds or less.
- The speed command of the motor should be 250rpm or higher.
- The ratio of machinery load inertia to motor shaft should be 100 times or less.
- The machinery system with a violent change of load inertia is not suitable.
- The acceleration/deceleration torque is more than rated torque 10% or above.

(2)Auto-gain tuning mode 2

When auto-gain tuning mode 1 is not satisfied the accurate approximation of load inertia, the auto-gain tuning mode 2 is recommended. The parameter PA02 should be set as "0003h" to perform this mode. During the tuning process, the load inertia ratio would not be approximated and the users have to write manually the value into PB06 by themselves.

Parameters and settings related of this mode are presented below:

Parameter NO	Abbr	Parameter name	User adjustable or auto-presumed
PA 03	ATUL	Auto-tuning response level setting	User adjustable
PB 06	GD1	The ratio of load inertia to motor shaft	User adjustable
PB 07	PG1	Position loop gain	auto-approximated
PB 08	VG1	Speed loop gain	auto-approximated
PB 09	VIC	Speed integral gain	auto-approximated

5.3.2.2 The flow of auto-gain tuning mode

The flow of auto-gain tuning mode for the servo drive could be presented below:

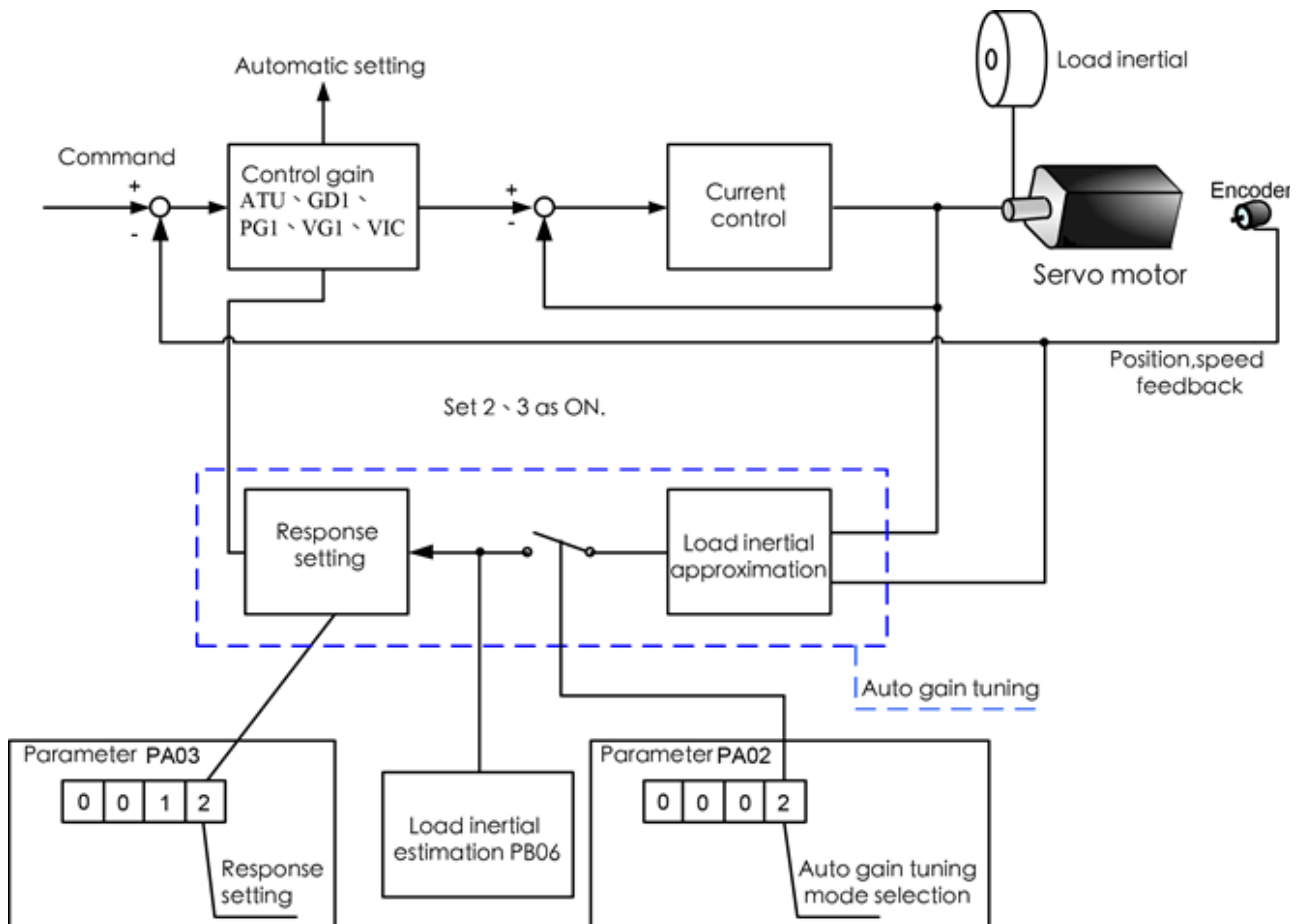

When the auto-gain tuning mode is performed, the following conditions should be satisfied.

1. As the mode 1 operated, at first execute the acceleration/deceleration routes of the motor, the ratio of load inertia to motor shaft would be approximated according to the current and speed. The PB06 would be updated (EEPROM) with the new approximated value every 30 minutes.
2. If the PB06 is known or the proper gain cannot be made by the auto-gain tuning mode 1, please use the auto-gain tuning mode 2 by the setting of PA02 and manually set the known value of PB06. Under this mode, the estimation of control gain would still compute.
3. With the settings of the inertia ratio and the response, the servo drive would tune the optimum gains during the acceleration/deceleration route. The result value of gain tuning would be written into EEPROM every 30 minutes. After power one of the drive, the saved value of the controller gain in the EEPROM would be used as the initial value for the operation of auto-gain tuning mode.

Since the auto-gain tuning mode 1 is made valid as the default from the factory, simply running the acceleration/ deceleration route of the motor would automatically obtain the optimum gains that match the machine. Merely changing the response level setting value as required completes the adjustment. The adjustment procedure is as follows.

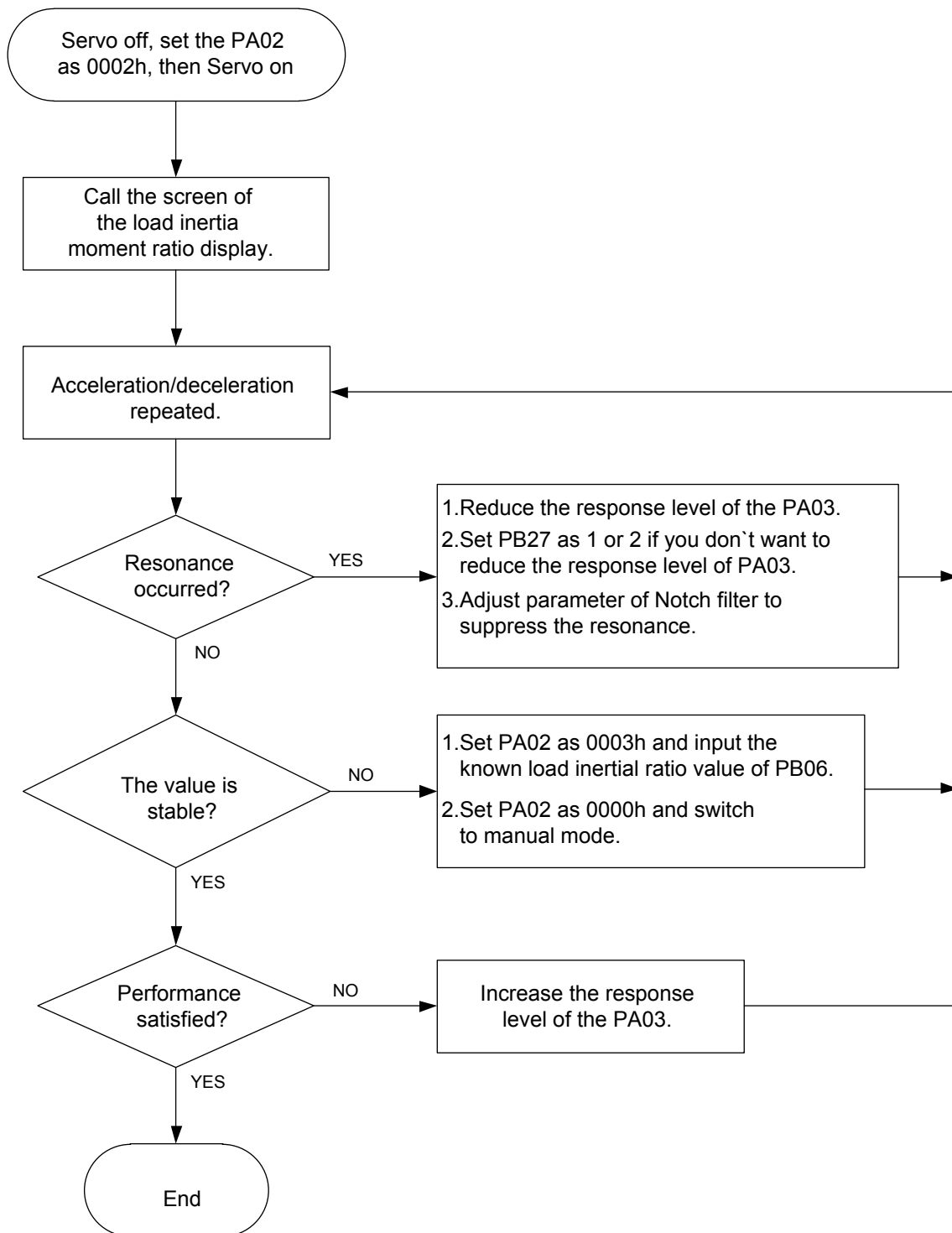

5.3.2.3 Response level setting of the auto-gain tuning mode

The parameter PA03 (response level setting) is related to the response of the whole servo system. As the response level setting is increased, the traceability and settling time for a command decreases, but a too high response level setting would generate vibration. Therefore, keep setting until the optimum response is obtained within the range without vibration.

If the response level setting which user desired would cause machine resonance, the machine resonance suppression filter (PB01, PB02, PB21, PB22) and the resonance suppression low-pass filter (PB03) could be employed to suppress machine resonance. Suppressing machine resonance may allow the response level setting to be higher. Refer to section 6.3.6 for more detail about suppressing machine resonance.

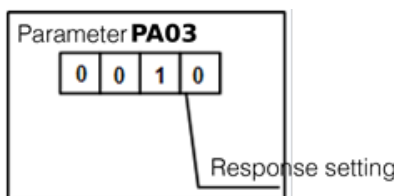

Response level setting	Machine rigidity	Speed loop response frequency (Hz)	Response level setting	Machine rigidity	Speed loop response frequency (Hz)
1	Low	10.0	17	Middle	67.1
2		11.3	18		75.6
3		12.7	19		85.2
4		14.3	20		95.9
5		16.1	21		108.0
6		18.1	22		121.7
7		20.4	23		137.1
8		23.0	24		154.4
9		25.9	25		173.9
10		29.2	26		195.9
11	Middle	32.9	27	High	220.6
12		37.0	28		248.5
13		41.7	29		279.9
14		47.0	30		315.3
15		52.9	31		355.1
16		59.6	32		400.0

- For the response level setting, it is recommended to use the level value from low response to high response gradually. It is probable to make resonance if the initial value is too high.
- The applicable ratio of load inertia to motor shaft is a reference. The actual range would vary with the different mechanical systems.

5.3.3 Manual gain tuning mode

The manual gain tuning mode is executed as the result of auto-gain tuning function is not suitable for the user's demand.

Adjustment of manual mode

For the applications of position control or speed control, the bandwidth is highly related with the machinery rigidity and environment. For machine tools which the high precision required, a high Bandwidth system response is necessary. However, a high response level setting could cause the machine resonance easily. Therefore, a high rigidity machine should be used for occasions that require a high response to avoid machine resonance.

If users have no idea about the permissible response of the machine, they should adopt a smaller gain value at first and then gradually increase the gain values until machine resonance occurred. Then users could reduce the gain values accordingly. Reference parameter values for users to adjust are listed in the following table:

Name	Abbr.	Sign	Setting range	Unit	Initial value	Control mode
Resonance suppression low-pass filter	NLP	PB03	0~10000	0.1ms	10	ALL
Position feed-forward gain value	FFC	PB05	0~200	%	0	Pt、Pr
The ratio of load inertia to motor shaft	GD1	PB06	0~1200	0.1 time	70	ALL
Position loop gain	PG1	PB07	4~1024	rad/s	45	Pt、Pr
Speed loop gain	VG1	PB08	40~9000	rad/s	183	ALL
Speed integral gain	VIC	PB09	1~1000	ms	34	ALL
Speed feed-forward gain	VFG	PB10	0~200	%	0	S、T

► Position loop gain (PG1)

This parameter determines the response level of the position loop. Increasing PG1 improves traceability, settling time and position error to a position command but a too high value will make overshooting or vibration to occur. Its formula is as follows:

PG1 setting value \leq (VG1 setting value)/(1+ratio of load inertial to motor shaft) \times 1/4

PG1 setting value \approx speed loop bandwidth \times 1/4

► Speed loop gain(VG1)

This parameter determines the response level of the speed loop. Increasing VG1 improves traceability to a speed command but a too high value will make machine resonance. The Speed loop gain is usually 4~6 times bigger than the position loop gain. As the position loop gain is greater than the speed loop gain, machine resonance or overshoot would be occurred easily.

Its formula is as follows:

$$\text{Speed loop response frequency(Hz)} = \frac{\text{Speed loop gain setting}}{(1+\text{ratio of load inertia moment to servo motor inertia moment}) \times 2\pi}$$

► Speed integral gain (VIC)

This parameter is to eliminate stationary deviation against a command. The smaller it is the better capability for the drive to eliminate stationary deviation. However, the machine with a large load inertia ratio or any vibration causing, the small value would cause the vibration easily.

Refer to the following formula as setting value.

$$\text{Speed integral compensation setting(ms)} \geq \frac{3000 \text{ to } 5000}{\text{Speed loop gain setting} / (1+\text{ratio of load inertia moment to servo motor inertia moment setting} \times 0.1)}$$

► Resonance suppression low-pass filter (NLP)

The larger the load inertia ratio is, the lower the system bandwidth is. To keep a relatively high bandwidth, a higher gain value may be required. Also the probability of resonance for the same machine would be increased. Thus the resonance suppression low-pass filter could be applied to eliminate the resonance. The higher setting value affords a better improvement about high frequency noises. Also a too large value could probably cause the entire system to be instable. It is because the higher setting value cause a larger phase lag of the servo drive. Refer to the following formula as setting value.

$$\text{Filter frequency (Hz)} = \frac{\text{Setting value of VG1} \times 10}{2\pi \times (1 + \text{Setting value of GDI} \times 0.1)}$$

► Position feed-forward gain (FFC)

To reduce the position error and position settling time, but if the value is set too large, a sudden acceleration or deceleration may cause overshoots. Also, a too large electronic gear ratio would cause noises

► Speed feed-forward gain(VFG)

To set the proper gain value would reduce the tracking time of speed command. Also, a too big value would cause overshoots during the sudden acceleration/deceleration command.

5.4 Parameter setting and operation for position control mode

(1) Power on

To switch off the SON signal of DI after the servo drive has turned on. The panel of the drive would show “Servo motor rotation speed” 2 second latter.

(2) Test operation

Confirm the state of the servo motor with the JOG test.

(3) Parameter setting

After wiring for position control, the following parameters should be set for this operation.

Parameter	Name	Setting Value	Description
PA01(Note1)	Control mode option	□□□0	Position control mode
PA02(Note2)	Gain tuning mode option	0002	Auto-gain tuning mode 1
PA03	Response level setting	0012	Middle rigidity
PA06	Numerator of the electronic gear ratio	1	Set the numerator as 1
PA07	Denominator of the electronic gear ratio	1	Set the denominator as 1
PA13	Pulse command option	Please refer to section 8.3 for details.	
PD15(Note 1)	Digital input filter time option	□□□2	Filter time constant is 4ms

Note 1: The modification of this parameter would be valid by power off once and power on again.

Note 2: This parameter cannot be set when SON-SG is open circuit.

(4) Servo on

Please operate SERVO ON as following procedure.

- (a) Turn on the control power of the servo drive.
- (b) Turn on the SON signal (SON-SG short circuit).

When the SON is activated, the drive is ready to run. The servo motor would immediately be magnetized and switched to the “SERVO LOCK” state.

(5) Forward/reverse rotation pulse train

At first make the servo motor run at a low speed and confirm the operation and rotary direction of the motor. If the pulse train commands are open collector type, PP and NP are used as input terminal. When the line drive signals applied, please use the PP- PG or NP-NG wiring. Use auto-gain tuning function or manually input the controller parameter and avoid the machine resonance. To adjust the PA03 to obtain the optimum speed response.

(6) Home return

Before this function being performed, check if there is the proper rotary direction and origin. Searching home could be executed if necessary.

(7) Stop

Take one of the following steps to stop running the motor.

- (a) SON signal off:
The shaft of servo motor is become rotatable.
- (b) Alarm has occurred :
The dynamic brake works and the servo motor suddenly stop running. EMG signal OFF
The same actions as above but the ALM message is displayed.
- (c) LSP,LSN signal OFF
LSP on is rotatable in CCW. LSN on is rotatable in CW. If it is off, the dynamic brake works.

5.5 Parameter setting and operation for speed control mode

(1) Power on

To switch off the SON signal of DI after the servo drive has turned on. The panel of the drive would show "Servo motor rotation speed" 2 second latter

(2) Test operation

Check if the state of the servo motor normal or not with the JOG test.

(3) Parameter setting

After wiring for speed control, the following parameters should be set for this operation.

Parameter	Name	Setting value	Description
PA01(Note 1)	Control mode option	□□□2	Speed control mode
PC05	Inner speed command 1	1000	Set as 1000rpm
PC06	Inner speed command 2	1500	Set as 1500rpm
PC07	Inner speed command 3	2000	Set as 2000rpm
PC01	Acceleration time constant	1000	Set as 1000ms
PC02	Deceleration time constant	500	Set as 500ms
PC03	S-curve acceleration/deceleration pattern	0	Disabled
PD15(Note 1)	Digital input filter time option	□□□2	Filter time constant is 4ms

Note 1: The modification of this parameter would be valid by power off once and power on again.

(4) Servo on

Please operate SERVO ON as following procedure.

- (a) Turn on the control power of the servo drive.
- (b) Turn on the SON signal (SON-SG short circuit).

When the SON is activated, the drive is ready to run. The servo motor would immediately be magnetized and switched to the "SERVO LOCK" state.

(5) Start

Choose the speed command with the SP1 and SP2 signals. Options are listed as below

(Note) External input signal		Speed command
SP2	SP1	
0	0	Speed analog command (VC)
0	1	Inner speed command1(PC 05)
1	0	Inner speed command2(PC 06)
1	1	Inner speed command3(PC 07)

After speed selection, the rotary direction is decided with the ST1 and ST2 signals. Options are listed as below.

(Note) External input signal		Speed command			
ST2	ST1	Speed analog command (VC)			Inner command
		+polarity	0V	-polarity	
0	0	Stop (Servo lock)	Stop (Servo lock)	Stop (Servo lock)	Stop (Servo lock)
0	1	CCW	Stop (Servo lock)	CW	CCW
1	0	CW		CCW	CW
1	1	Stop (Servo lock)	Stop (Servo lock)	Stop (Servo lock)	Stop (Servo lock)

Note:OFF (SG is open circuit.) 1:ON (SG is short circuit.)

At first make the servo motor run at a low speed and check if the sequence correct or not. With the status display, user could check the motor speed, cumulative pulses of command, effective load ratio, etc. Use auto-gain tuning function or manually input the controller parameters and avoid the machine resonance. To adjust the PA03 to obtain the optimum speed response.

(6) Stop

Take one of the following steps to stop running the motor.

- (a) SON signal off:
The shaft of servo motor is become rotatable.
- (b) Alarm has occurred:
The dynamic brake works and the servo motor suddenly stop running.

(c)EMG OFF:

The same actions as above but the ALM message is displayed

(d)LSP/LSN signal off:

LSP on is rotatable in CCW. LSN on is rotatable in CW. If it is off, the dynamic brake works.

(f)If ST1 and ST2 are both on or both off, the motor would decelerate to stop.

5.6 Parameter setting and operation for torque control mode

(1) Power on

To switch off the SON signal of DI after the servo drive has turned on. The panel of the drive would show “U (Torque command voltage)” 2 second latter.

(2) Test operation

Confirm the state of the servo motor with the JOG test.

(3) Parameter setting

After wiring for torque control, the following parameters should be set for this operation.

Parameter	Name	Setting	Parameter
PA 01(Note1)	Control mode option	□□□4	Torque control mode
PC 05	Inner speed limit 1	1000	Set as 1000rpm
PC 06	Inner speed limit 2	1500	Set as 1500rpm
PC 07	Inner speed limit 3	2000	Set as 2000rpm
PC 01	Acceleration time constant	1000	Set as 1000ms
PC 02	Deceleration time constant	500	Set as 500ms
PC 03	S-curve acceleration/deceleration pattern	0	Disabled
PD15	Digital input filter time option	□□□2	Filter time constant is 4ms
PA 05	Inner torque limit 1	50	50% of maximum torque as a limit

(4)Servo on

Please operate SERVO ON as following procedure.

(a)Turn on the control power of the servo drive.

(b)Turn on the SON signal (SON-SG short circuit).

When the SON is activated, the drive is ready to run. The servo motor would not be magnetized and the shaft is rotatable.

(5) Start

Choose the speed limit with the SP1 and SP2 signals. The motor runs in CCW as the RS1 activated. The motor runs in CW as the RS2 activated. At first to run the servo motor at a low speed to check if the sequence correct or not. If the sequence is unexpected, check whether the input signal is proper.

(6) Stop

Take one of the following steps to stop running the motor.

(a)SON signal off

The shaft of servo motor is become rotatable.

(b)Alarm has occurred

The dynamic brake works and the servo motor suddenly stop running.

(c)EMG OFF

The same actions as above but the ALM message is displayed.

(d)LSP/LSN signal off:

RS1 on is rotatable in CCW. RS2 on is rotatable in CW. If it is off, the dynamic brake works.

6. Control function

6.1 Control mode option

There are 4 basic operation modes for Shihlin servo drive: position control with terminals input, position control with inner registers, speed control, torque control. The drive could be operated in single mode or hybrid mode. All operation modes are described as below.

Mode		Sign	PA 01 Setting	Description
Single mode	Position control (terminal input)	Pt	0000	The drive receives the command to run the motor to approach the goal. The command is received via the terminals and is in the form of pulse trains
	Position control (inner register)	Pr	0010	The drive receives the command to run the motor to approach the goal. The command source is the inner register (63 sets of register) which could be assigned by DI signals.
	Speed control	S	0002	The drive runs the motor to the target speed. The command source which is an analog voltage or the inner register (7 sets of register) could be switched by DI signals.
	Torque control	T	0004	The drive receives the command to run the motor to generate the desired torque. The command source is the analog voltage.
Hybrid mode	Position control (terminal input)- speed	Pt-S	0001	Pt/S is switched mutually via the DI (LOP) signal.
	Position control (terminals input)- torque	Pt-T	0005	Pt/T is switched mutually via the DI (LOP) signal.
	Position control (inner register)- speed	Pr-S	0011	Pr/S is switched mutually via the DI (LOP) signal.
	Position control (inner register)- torque	Pr-T	0015	Pr/T is switched mutually via the DI (LOP) signal.
	Speed - torque control	S-T	0003	S/T is switched mutually via the DI (LOP) signal.

- The modification of PA01 would be valid by power off once and power on again.

6.2 Torque control mode

Torque control mode is often applied for such occasions: winding machines, printing press, injection molding machines, etc. The torque command is analog voltage signals which control the output torque of the servo motor by external voltage. The basic torque control blocks are shown as below.

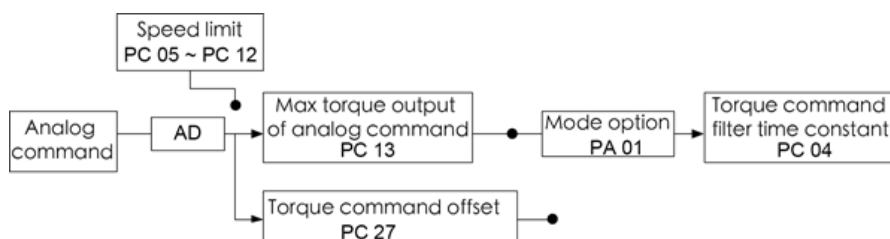

Select the model option to torque mode. The input command for torque control is an analog $\pm 10V$ voltage. After A/D process, torque output command and torque command offset process, the expected torque and speed will be output.

6.2.1 Output proportion of maximum torque analog command

Output proportion is the relationship between the applied voltage of the torque analog command and the torque generated by the servo motor.

Name	Sign	Setting range	Unit	Initial value	Control mode
Torque generated of maximum analog command	PC 13	0~2000	%	100	Pt、Pr、S、T

If the setting value of PC13 is 100%, the 100% rated torque of servo motor would be generated when the applied voltage of torque command is 10V. If the applied voltage of torque command is 5V, the generated torque would be the 50% rated torque. The conversion is listed as follows.

The generated torque (%) = applied voltage of torque command/10* the setting value of PC13

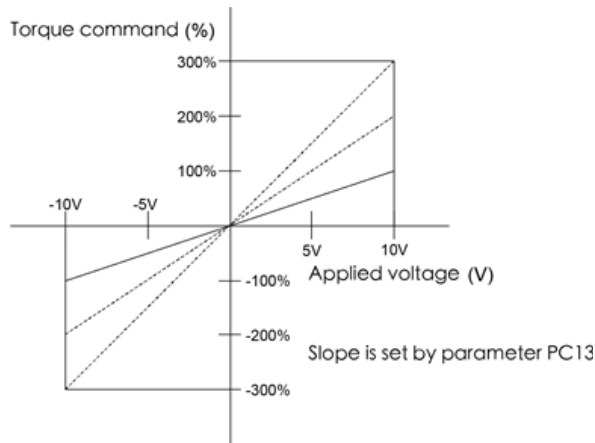

6.2.2 Torque analog command offset

When the torque analog command input is 0V, there may be still an offset voltage which will cause a slow motor rotation. In such case, the user could use the parameter PC27 to correct the bias voltage. The parameter description is as follows.

Name	Sign	Setting range	Unit	Initial value	Control mode
Torque analog command offset	PC 27	-8000~8000	mV	0	S · T

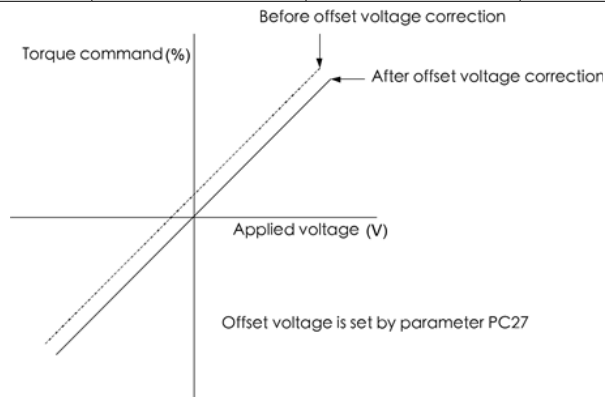

6.2.3 Torque analog command smoothing

By setting the filter time constant of torque analog command, the user could run the servo motor smoothly in response to a sudden torque command. The parameter description is as follows.

Name	Sign	Setting range	Unit	Initial value	Control mode
Torque command filter time constant	PB19	0~5000	ms	0	T

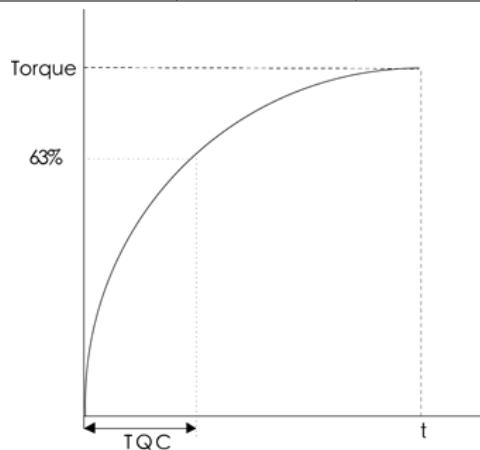

6.2.4 Torque limit of torque control mode

The parameter PA05 and PC25 are used to limit the generated torque of the servo motor when the torque control mode is performed. The description is as follows.

Name	Abbr.	Sign	Setting range	Unit	Initial value	Control mode
Inner torque limit 1	TL1	PA 05	0~100	%	100	Pt、Pr、S、T
Inner torque limit 2	TL2	PC 25	0~100	%	100	Pt、Pr、S、T

The TL1 signal function of CN1 is also described again as follows.

Name	Abbr.	Description	Control mode
Inner torque limit option	TL1	When this signal is applied, make the PD02 ~ PD09 or PD21 ~ PD24 usable at first. Open TL1-SG to make inner torque limit 2 valid (PC25).	Pt、Pr、S、T

Users can use the internal torque limiting (TL1) and select internal torque limit 2 (PC 25) to set the parameter PD02~PD09 or PD21~PD2. There are two different results which are chosen by the switch status of DI.

(Note) DI signal status	The valid value of torque limit
TL1	
0	The setting value of PA05
1	If the PC25 is greater than the PA05, the PA05 is valid. If the PC25 is less than the PA05, the PC25 is valid.

Note: 0:OFF(SG is open-circuit) 1:ON (SG is short-circuit)

6.2.5 Speed limit of torque control mode

Under the torque control mode, the various speed limits could be applied by the SP1, SP2, SP3 and the external analog signal. There are 8 combinations which are listed below for user to choose.

DI status	Valid option	(Note) DI signal status		Speed limit	Limit range	Related parameter	
		SP2	SP1				
SP3 is invalid (default value)	VCM	0	0	Speed analog limit(VC)	±10V	PC 12	
	SC1	0	1	Inner speed limit1	-4500 ~ 4500	PC 05	
	SC2	1	0	Inner speed limit2	-4500 ~ 4500	PC 06	
	SC3	1	1	Inner speed limit3	-4500 ~ 4500	PC 07	
DI status	Valid option	SP3	SP2	SP1	Speed limit	Limit range	Related parameter
SP3 is valid	VCM	0	0	0	Speed analog limit(VC)	±10V	PC 12
	SC1	0	0	1	Inner speed limit1	-4500 ~ 4500	PC 05
	SC2	0	1	0	Inner speed limit2	-4500 ~ 4500	PC 06
	SC3	0	1	1	Inner speed limit3	-4500 ~ 4500	PC 07
	SC4	1	0	0	Inner speed limit4	-4500 ~ 4500	PC 08
	SC5	1	0	1	Inner speed limit5	-4500 ~ 4500	PC 09
	SC6	1	1	0	Inner speed limit6	-4500 ~ 4500	PC 10
SC7	1	1	1	Inner speed limit7	-4500 ~ 4500	PC 11	

Note: 0:OFF (SG is open-circuit) 1:ON (SG is short-circuit)

- When the external speed analog limit is applied, check the initial 0 voltage and PC12 value which are not permissible to exceed the motor rated speed otherwise damages would be caused.
- To make the SP3 of DI valid by setting PD02 to PD09 if the option SC4 to SC7 are used.

The parameters related to the function of inner speed limit are described below.

Name	Sign	Setting range	Unit	Initial value	Control mode
Inner speed limit 1	PC 05	0 ~ instant permissible speed	rpm	100	T
Inner speed limit 2	PC 06	0 ~ instant permissible speed	rpm	500	T
Inner speed limit 3	PC 07	0 ~ instant permissible speed	rpm	1000	T
Inner speed limit 4	PC 08	0 ~ instant permissible speed	rpm	200	T
Inner speed limit 5	PC 09	0 ~ instant permissible speed	rpm	300	T
Inner speed limit 6	PC 10	0 ~ instant permissible speed	rpm	500	T
Inner speed limit 7	PC 11	0 ~ instant permissible speed	rpm	800	T

6.3 Speed control mode

Speed control is often applied for occasions where is CNC machine, drilling machine, etc. The command source is analog signal or inner register. The analog signal is the external voltage signal. The inner command could be performed by the following 2 ways: (1) Use the inner registers (PC05 to PC11) to set the various commands then switch SP1, SP2, and SP3 to change the demand speed. (2) Use the communication software to modify the value of speed command register.

To avoid the discontinuity, the drives afford users the smooth S-pattern running in purpose of motor smooth operation when users switch to different speeds. In fully closed-loop system, this device uses gain and cumulative integration type (PI) controller. There are 2 control modes (manual and automatic) available.

The manual mode enables users to set all related parameters while the automatic functions were off. The automatic mode provides an estimation of load inertia ratio and parameters adjusted function to be initial value. In addition, a simple mode is designed to provide users a robust control which could instantaneously suppress external load interference. Simple operation pattern can suppress external load interference and body resonance and tolerant load inertia variation in real-time. The basic speed control blocks are shown as below.

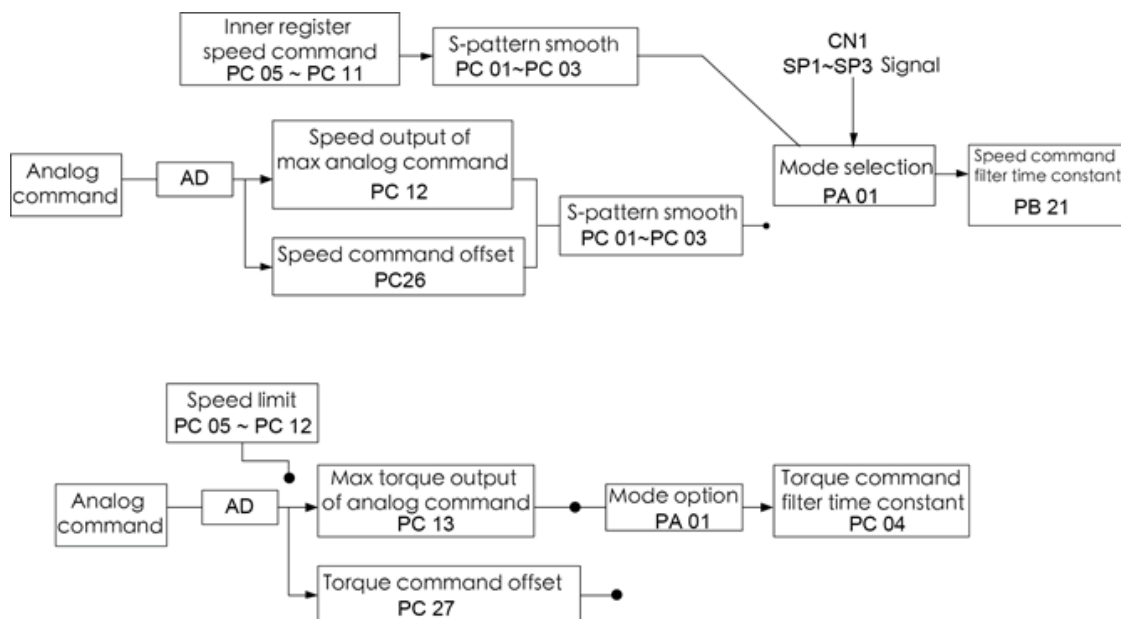

The above part of the graphic is internal speed command which with size of speed command written by users could switch by the digital input terminal DI. While the bottom part of the graph is external analog inputs $\pm 10V$ voltage. After A/D processing, calculate command output which user set (proportional) and voltage offset output.

The S-pattern smooth process and speed filter are recommended to suppress the discontinuity

6.3.1 Selection of speed command

Shihlin servo have two types of speed command , one is setting 7 speed command by internal parameters; the other is external inputs $\pm 10V$ analog voltage commands, there are 8 combinations which are listed below for user to choose.

DI status	Valid option	(Note) DI signal status		Speed command	Setting range	Related parameter
		SP2	SP1			
SP3 is invalid (default value)	VCM	0	0	Speed Analog Command (VC)	$\pm 10V$	PC 12
	SC1	0	1	Inner speed command 1	-4500 ~ 4500	PC 05
	SC2	1	0	Inner speed command 2	-4500 ~ 4500	PC 06
	SC3	1	1	Inner speed command 3	-4500 ~ 4500	PC 07

SP3 is valid	Valid option	SP3	SP2	SP1	Speed command	Setting range	Related parameter
	VCM	0	0	0	Speed Analog Command (VC)	±10V	PC 12
	SC1	0	0	1	Inner speed command 1	-4500 ~ 4500	PC 05
	SC2	0	1	0	Inner speed command 2	-4500 ~ 4500	PC 06
	SC3	0	1	1	Inner speed command 3	-4500 ~ 4500	PC 07
	SC4	1	0	0	Inner speed command 4	-4500 ~ 4500	PC 08
	SC5	1	0	1	Inner speed command 5	-4500 ~ 4500	PC 09
	SC6	1	1	0	Inner speed command 6	-4500 ~ 4500	PC 10
	SC7	1	1	1	Inner speed command 7	-4500 ~ 4500	PC 11

Note 0:OFF (SG is open-circuit) 1:ON (SG is short-circuit)

- When the external speed analog limit is applied, check the initial 0 voltage and PC12 value which are not permissible to exceed the motor rated speed otherwise damages would be caused.
- To make the SP3 valid by setting PD02 ~ PD09 or PD21~PD24 if the option SC4 to SC7 are used.

6.3.2 Output speed of maximum speed analog command

The relationship between the applied voltage of the speed analog command and the output speed is described below:

Name	Sign	Setting range	Unit	Initial value	Control mode
Output speed of maximum analog voltage command	PC 12	0 ~30000	rpm	3000	S · T

This value decides the output speed while the maximum permissible voltage is applied. If the PC12 is 3000, the motor would rotate at 3000rpm when the applied voltage of speed command is 10V. If the applied voltage of speed command is 5V, the rotary speed would be 1500rpm. The conversion is listed as follows.

The output speed [rpm] = the setting value of PC12* applied voltage of speed command/10

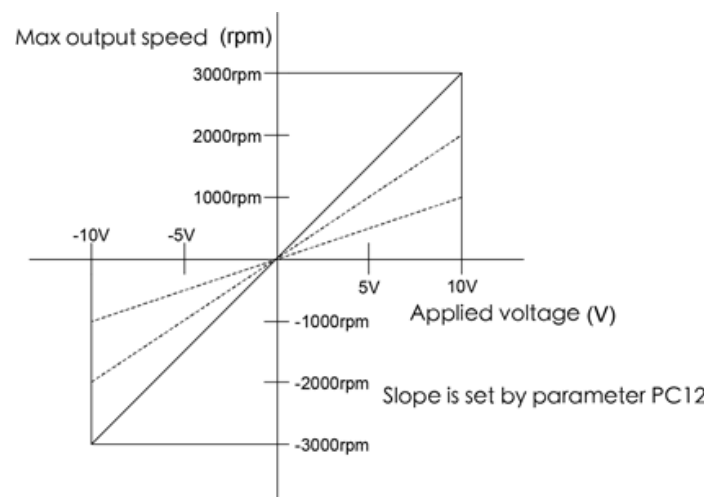

6.3.3 Speed analog command smoothing

If the speed command changed violently, vibration or noise or even overshoot may be occurred by the motor. Users could use related parameters for smoothing process to suppress those needless impacts. The acceleration time constant could be used to adjust the slope of speed pattern from static state to the speed command set by the user. The deceleration time constant could be used to adjust the slope from the rotary state to the static state. The S-pattern acceleration/deceleration time constant could be used to adjust the stability when starting or stopping the motor.

Name	Abbr.	Sign	Setting range	Unit	Initial value	Control mode
Acceleration time constant [ms]	STA	PC 01	0~20000	ms	200	S · T
Deceleration time constant [ms]	STB	PC 02	0~20000	ms	200	S · T
S-pattern acc./dec. time constant [ms]	STC	PC 03	0~10000	ms	0	Pr · S · T

The 3 parameters will be described in detail as follows.

Acceleration time constant :

This parameter is the time spent for the motor from 0 rpm to the rated speed and it is defined as “acceleration time constant”. For example, if the rated speed of the servo motor is 3000 rpm and this parameter is set as 3000 (3s). In such case, the motor accelerating from 0 rpm to 3000 rpm would take 3 seconds. When the speed command is set at 1000 rpm, the motor take 1 second to accelerate from 0 rpm to 1000 rpm.

Deceleration time constant :

The time spent for the motor to decelerate from the rated speed to 0 rpm is called “deceleration time constant”. For example, if the current speed of the servo motor is 3000 rpm and this parameter is set as 3000 (3s). In such case, the motor decelerating from 3000 rpm to 0 rpm would take 3 second. When the running speed is 1000 rpm, the motor take 1 second to decelerate from 1000 rpm to 0 rpm.

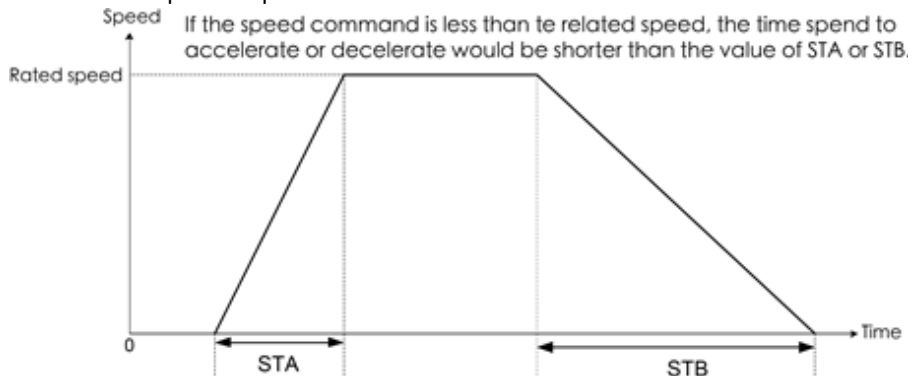

S-pattern acc./dec. time constant :

The method of S-pattern acceleration/deceleration time constants is to employ a three-step curve during the acceleration or deceleration process in order to soothe the vibration during starting or stopping the motor. Setting an appropriate STC could improve the stability of the motor during startup and stop. The initial S-pattern acceleration/ deceleration constants are set as 0 second. Users are recommended to enable this function when the speed control mode is performed.

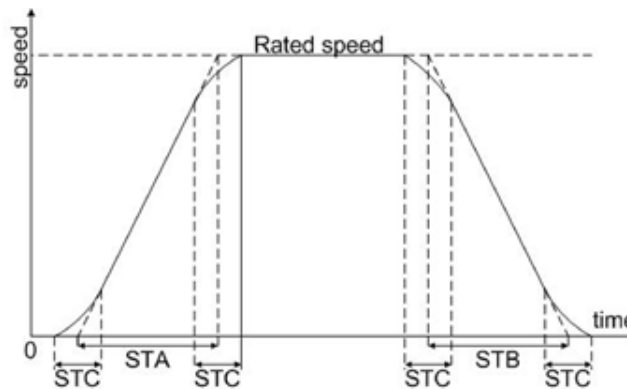

- Protection during acceleration/deceleration is occupied in the speed control mode.
- STA, STB, STC could be set independently. Even if STC is “0”, a trapezoidal-pattern is provided.

Low-pass filter smooth time constant :

Name	Abbr.	Sign	Setting range	Unit	Initial value	Control mode
Speed low-pass filter smooth time constant[ms]	SFLT	PB 18	0~1000	ms	0	S、T

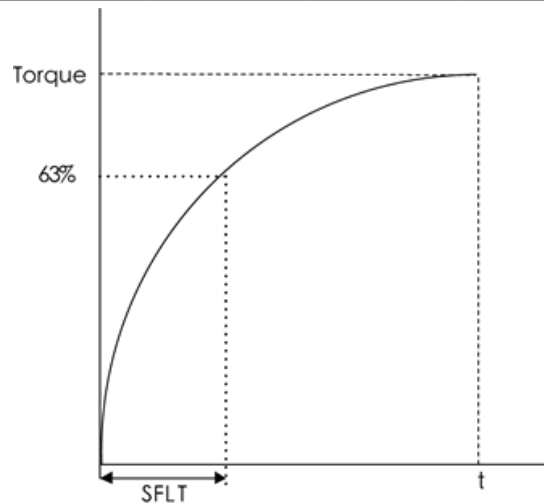

A larger parameter value would soothe the speed command more obviously. However, the response would slow down as well. If it is set as zero, this function is disabled.

6.3.4 Torque limit of speed control mode

When this mode is applied, there are two major parameters: PA05 and PC25 which are related to the torque limit function. They are explained in the following table.

Name	Abbr.	Sign	Setting range	Unit	Initial value	Control mode
Inner torque limit 1	TL1	PA 05	0~100	%	100	Pt、Pr、S、T
Inner torque limit 2	TL2	PC 25	0~100	%	100	Pt、Pr、S、T

Here are 3 pin functions of CN1: 1 analog voltage input and 2 DI inputs which are described below:

Pin/Signal name	Abbr.	Description	Control mode
Torque analog limit	TLA	This signal is valid by the setting of PD02~PD09 or PD21~PD24 to make TL enable. As TLA is valid, the torque output would be limited. When TLA is connected to the positive polarity of the power source, a maximum torque will be generated at +10V.	Pt、Pr、S
Torque limit option	TL	Set the PD02~PD09 or PD21~PD24 parameter to enable this signal. As TL-SG is open circuit, the inner torque limit 1(PA05) is valid. In case of short circuit, the torque analog limitation (TLA) effective.	Pt、Pr、S
Inner torque limit option	TL1	Set the PD02~PD09 or PD21~PD24 parameter to enable this signal. As TL1-SG is short circuit, the Inner torque limit 2(PC25) effective.	Pt、Pr、S、T

Use the internal torque limit selection (TL1) to set parameter PD02 ~ PD09, than the internal torque limit 2 (PC 25) can be selected. There are 4 combinations which are decided by the signal state of TL and TL1. The torque limit value (TL), internal torque limit selection (TL1) and torque limit analog (TLA) restrictions in the following table for selection:

(Note) DI signal status		The valid value of torque limit
TL1	TL	
0	0	The setting value of PA05
0	1	If TLA is less than PA05, then TLA is valid. If TLA is greater than PA05 then PA05 is valid.
1	0	If PC25 is less than PA05, then PC25 is valid. If PC25 is greater than PA05, then PA05 is valid.
1	1	If PC25 is less than TLA, then PC25 is valid. If PC25 is greater than TLA, then TLA is valid.

Note 0: OFF(TL1-SG or TL-SG is open-circuit), 1:ON (TL1-SG or TL-SG is short-circuit)

If the generated torque suits the value of PA05 or PC25 or torque analog limit, the TLC of DO signal becomes conductive with SG.

Pin/Signal name	Abbr.	Description	Control mode
Torque limiting control	TLC	TLC-SG is conductive as the generated torque reaches the inner torque limit 1(PA05), or the torque analog limit (TLA).TLC-SG is isolated when SERVO ON (SON) is off.	Pt、Pr、S

6.3.5 Adjustment of speed loop gain

There are some parameters related to inner speed control loop for users to adjust. Set the value of the PA02 to use the auto-gain tuning function or manual-gain tuning function. If auto-gain tuning function is performed, the load inertia ratio would be approximated continuously and the control gain value would be set automatically. If manual-gain tuning is performed, users have to enter the proper value of the load inertia ratio and control gain value. At this time, all automatic or auxiliary functions about inner speed control loop would be disabled. The block diagram of inner speed control loop is presented as follows:

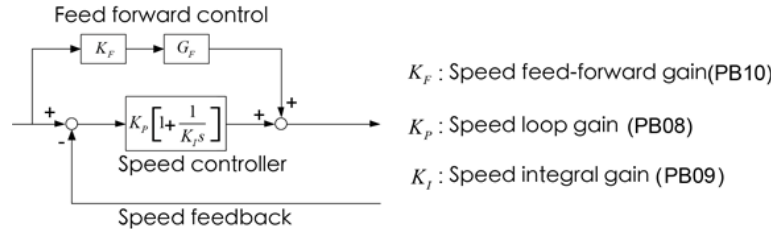

Parameters and settings related of this mode are presented below.

Name	Abbr.	Sign	Setting range	Unit	Initial value	Control mode
Gain tuning mode option	ATUM	PA02	0000h~0003h	-	0002h	Pt、Pr、S、T
Auto-tuning response level setting	ATUL	PA03	1~32	-	10	Pt、Pr、S、T
Speed loop gain	VG1	PB08	40~9000	rad/s	183	Pt、Pr、S
Speed integral gain	VIC	PB 09	1~1000	ms	34	Pt、Pr、S
Speed feed-forward gain	VFG	PB 10	0~200	%	0	S

Auto-gain tuning mode :

The drive would tune the optimum gains during the acceleration/deceleration route. Refer to section 5.3.2 for further details.

Manual-gain tuning mode :

When the PA02 value is 0000 or 0001, the effective parameters are: speed loop gain (PB08), speed integral gain (PB09) and speed feed-forward gain (PB10). When PA02 is set as 0001, the servo drive would automatically enable an interference compensator. This function could reduce torque ripple, overshoot and speed ripple. It is suitable for systems with load changed violently. Besides, users should avoid applying this compensator on the system which the ratio of load inertia to motor shaft is greater than 10 times. If necessary, the related parameters should be adjusted according to the various cases. The schematic diagram is as follows.

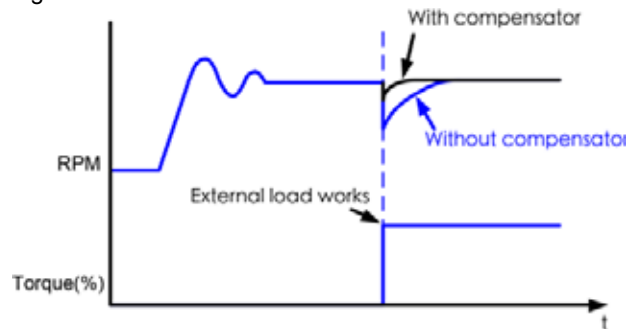

Parameters for manual-gain tuning mode

Speed loop gain :

Increasing this parameter would improve the bandwidth of speed control loop, but a too large value would cause the mechanism vibration. Therefore, it is recommended to operate the auto-gain tuning mode to approximate proper values at first. If the value could not satisfy the requirement, to increase this value gradually until the mechanism vibration occurred.

Speed integral gain :

Decreasing this parameter would improve the low-frequency rigidity of speed control loop and reduce the speed stability errors. On the other hand, a too small value would cause the phase delay to make an instable system.

Speed feed-forward gain :

The speed feed-forward gain could reduce the phase lag errors, and increase the traceability. If the setting value is near 100, the dynamic tracking error would be very small and the pre-compensation will be the most completed. If the setting value is too low, the improvement would not obvious. But a too high value would cause the system vibration easily.

6.3.6 Resonance suppression filter

(1)Auto high frequency resonance suppression function :

When the mechanism with low rigidity generates resonance by reason of the large bandwidth or the large rigidity setting value of the servo drive. If the mechanism factors could not be adjusted, Shihlin servo drive provides 3 resonance filter frequencies and 1 resonance suppression low-pass filter for users to make adjustment. Some parameters related to resonance suppression filter are introduced below.

Name	Abbr.	Sign	Setting range	Unit	Initial value	Control mode
Auto resonance suppression mode	ANCF	PB27	0~2	-	1	Pt、Pr、S、T
Auto resonance detection level	ANCL	PB28	1~300	%	50	Pt、Pr、S、T
Machine resonance suppression filter (1)	NHF1	PB01	50~4000	Hz	1000	Pt、Pr、S、T
Machine resonance suppression attenuation (1)	NHD1	PB02	0~32	dB	0	Pt、Pr、S、T
Machine resonance suppression filter (2)	NHF2	PB21	10~4000	Hz	1000	Pt、Pr、S、T
Machine resonance suppression attenuation (2)	NHD2	PB22	0~32	dB	0	Pt、Pr、S、T
Machine resonance suppression filter (3)	NHF3	PB25	10~4000	Hz	1000	Pt、Pr、S、T
Machine resonance suppression attenuation (3)	NHD3	PB26	0~32	dB	0	Pt、Pr、S、T
Resonance suppression low-pass filter	NLP	PB03	0~10000	0.1ms	10	Pt、Pr、S、T

► Manual suppression method :

There are three sets of auto resonance suppression filter provided by SDH drive which one is PB01 and PB02, the second one is PB21 and PB22 and the third one is PB25 and PB26; And there are also one set of low pass auto resonance suppression filter which is PB03. PB01、PB21、PB25 are suppression frequencies; PB02、PB22、PB26 are suppression attenuation rates and PB03 is time constant.

If resonance frequency of machine is known, users can set the frequency of filter and increase the attenuation rate step by step in order to have no resonance (Note 2) or slowly increasing low-pass filter time constant (reduce bandwidth of the low-pass filter) to have no resonance, but this will reduce the bandwidth of the system.

► Auto suppression method :

There are two sets of auto resonance suppression filter provided by SDH drive which one is PB01 and PB02, the second one is PB21 and PB22; PB01、PB21 are suppression frequencies; PB02、PB22 are suppression attenuation rates.

When resonance occurs, users who do not know resonance frequency can set PB27 to be 1 or 2 to operate the auto resonance suppression. The drive will detect resonant frequency and attenuation rate automatically, and then set detected result in the first filter and the second filter (Note 1).

If PB27 is set to 1, PB27 will automatically set back to 0 after finishing detecting; if PB27 is set to 2, it will continue to detect the resonance and suppression. Please refer to the following table for the parameter flow of PB27.

When PB27 is set to 1 or 2 and the resonance still persists, please check if the value of PB02 or PB22 is 32, if one of it is 32 that mean this resonance could not be suppressed by filter efficiency. Please reduce system bandwidth and estimate again in such case. If the value is less than 32 and bigger than 0 means the resonant frequency have been detected in auto detection mode but probably the attenuation is not enough to let have no resonance (Note 1). Users can increase attenuation rate (Note 2) in such case. If the PB02 or PB22 is 0 means there is no resonance frequency be detected, it is possible from the detecting level (PB28) is too high. It is recommended to reduce the detecting level and set PB27 to be 1 or 2 to detect again. Please see the chart below for auto resonance suppression flow.

Note 1. Drive will detect the most suitable not the best attenuation rate to ensure stability of the system

Note 2. Note that when adjust the attenuation rate manually, the setting value is too large may cause system instability.

PB27 Parameter flowchart		
PB27 Current value	PB27 Desired value	Function
0	1	Clear the setting value of PB01~02, 21~22 and enable auto resonance suppression function.
0	2	Clear the setting value of PB01~02, 21~22 and enable auto resonance suppression function continuously.
1	0	Save the setting value of PB01~02, 21~22 and disable auto resonance suppression function.
1	1	Clear the setting value of PB01~02, 21~22 and enable auto resonance suppression function.
1	2	Do not clear the setting value of PB01~02, 21~22 and enable auto resonance suppression function continuously.
2	0	Save the setting value of PB01~02, 21~22 and disable auto resonance suppression function.
2	1	Clear the setting value of PB01~02, 21~22 and enable auto resonance suppression function.
2	2	Do not clear the setting value of PB01~02, 21~22 and enable auto resonance suppression function continuously.

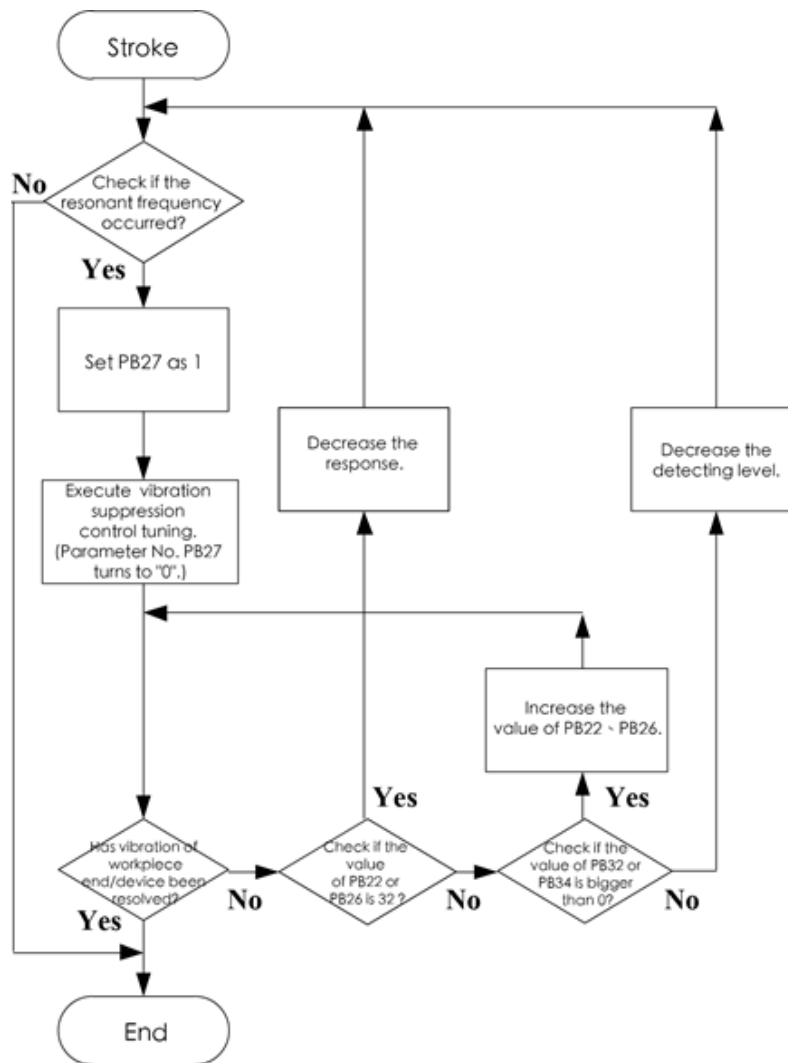

(2)Auto low frequency resonance suppression function :

When the command changes instantly due to lack of rigidity makes the transmission side and the load side of the motor cannot be synchronized will cause mechanical vibration, influence position accurate and defect-free rate for product. This phenomenon would usually be improved by reducing bandwidth of system, but it will lose the response. In order to do resonance suppression without reducing the bandwidth, the SDH servo drive provides the method of "Auto low frequency resonance suppression function" which parameters, setting range and the initial values are shown in the following table.

And provides two low-frequency filter, users can operate manual or auto resonance suppression according to their needs.

Name	Abbr.	Sign	Setting range	Unit	Initial value	Control mode
Auto low frequency resonance suppression mode	AVSM	PB29	0~1	-	0	Pt · Pr
Low frequency resonance detection level	VCL	PB30	1~8000	pulse	50	Pt · Pr
Low frequency resonance suppression frequency (1)	VSF1	PB31	1~3000	0.1Hz	100	Pt · Pr
Low frequency resonance suppression gain (1)	VSG1	PB32	0~15	-	0	Pt · Pr
Low frequency resonance suppression frequency (2)	VSF2	PB33	1~3000	0.1Hz	100	Pt · Pr
Low frequency resonance suppression gain(2)	VSG2	PB34	0~15	-	0	Pt · Pr

► Manual suppression method :

There are two sets of auto resonance suppression filter for users to set manually which one is PB31 and PB32, the second one is PB33 and PB34; PB31 · PB33 are suppression frequencies; PB32 · PB34 are suppression gain.

If resonance frequency of machine is known, users can set the frequency of filter at PB31 · PB33 and set PB32 · PB34 to '1' where '1' means start to open suppression function and '0' means close suppression function.

Increase the gain value to enhance the response. (Note 1)

Increase the attenuation rate step by step in order to have no resonance (Note 2) or slowly increasing low-pass filter time constant (reduce bandwidth of the low-pass filter) to have no resonance, but this will reduce the bandwidth of the system.

► Auto suppression method :

There are two sets of auto resonance suppression filter for users to operate auto low frequency resonant suppression which one is PB31 and PB32, the second one is PB33 and PB34; PB21 ~ PB25 are suppression frequencies; PB22 ~ PB26 are suppression attenuation rates.

When resonance occurs, users who do not know resonance frequency can set PB29 to be 1 to operate the auto resonance suppression. The drive will detect resonant frequency and attenuation rate automatically, then set detected result in PB31 ~ PB33 and set 1 to PB32 ~ PB34 to start suppression function.

PB29 will automatically set back to 0 after finishing detecting; Please refer to the following table for the parameter flow of PB29.

When PB29 is set to 1 and the resonance still persists, please check if the value of PB32 or PB34 is 0, if one of it is 0 that means this resonance could not be suppressed by filter efficiency. Please reduce attenuation rate (Note 2) in such case. If the PB32 or PB34 is not 0 means resonance frequency detecting is faulty, it is possible from the detecting level (PB28) is too low. It is recommended to increase the detecting level and detect again. Please see the chart below for auto resonance suppression flow.

Note 1: If the value of gain is too high, motor would not operate smoothly.

Note 2: Swing detecting level means the value of vibration peak. Unit: pulse.

PB29 parameter flow		
PB29 Current Value	PB29 Desired Value	Function
0	1	Clear the setting value of PB31~34 and enable auto resonance suppression function.
1	0	Save the setting value of PB31~34 and disable auto resonance suppression function
1	1	Clear the setting value of PB31~34 and enable auto resonance suppression function.

Auto resonance suppression flowchart:

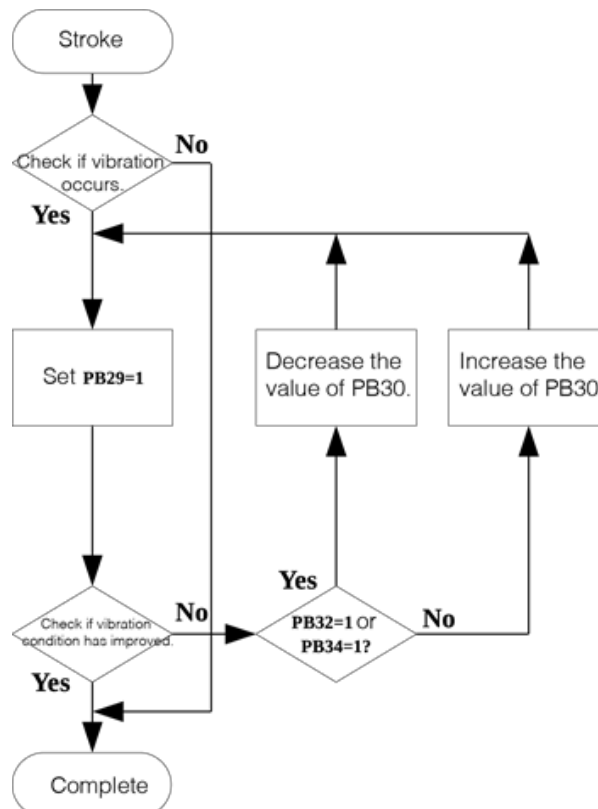

6.3.7 Gain switch function

The gain switch could be performed for the drive during the running or stop status of the motor. The programmable DI pins could be set as the function of gain switch. If this function is applied, the gain tuning mode option (PA02) should be set as "0000" or "0001". The gain switch function is invalid under the auto-gain tuning mode option.

Applicable occasions are listed below.

- (1) The rotation noises of motor are loud due to the large gain value setting.
- (2) The load inertia ratio of mechanism is changed violently during the route.
- (3) To improve the response or to shorten the settling time of the machinery system.

The relevant parameters and the detail descriptions are listed below.

Name	Name Abbr.	Sign	Setting range	Unit	Initial value	Control mode
The ratio of load inertia to motor shaft	GD1	PB 06	0~1200	0.1time	70	Pt · Pr · S
Position loop gain	PG1	PB07	4~1024	rad/s	45	Pt · Pr
Speed loop gain	VG1	PB08	40~9000	rad/s	183	Pt · Pr · S
Speed integral gain	VIC	PB09	1~1000	ms	34	Pt · Pr · S
Gain switch option	CDP	PB11	0000h~0008h	-	0000H	Pt · Pr · S
Gain switch condition value	CDS	PB12	0~4000000	By parameter setting	10	Pt · Pr · S
Gain switch time constant	CDT	PB13	0~1000	ms	1	Pt · Pr · S
The ratio 2 of load inertia to motor shaft	GD2	PB14	0~1200	0.1time	70	Pt · Pr · S
Position loop gain change ratio	PG2	PB15	10~500	%	100	Pt · Pr
Speed loop gain change ratio	VG2	PB16	10~500	%	100	Pt · Pr · S
Speed integral gain change ratio	VIC2	PB17	10~500	%	100	Pt · Pr · S

Parameters related to gain switching are described below.

(1) The method of gain tuning for GD1, PG1, VG1, VIC (PB06~PB09) parameters is the same as manual-gain tuning mode, but they are changeable under this gain switch operation.

(2) Gain switch option CDP (PB11)

Used to set the gain changing condition. Enable the trigger condition in the lowest digit. If users set "1" here, they could use the CDP signal of DI for gain changing. The CDP signal could be assigned to any one of the 8 DI pins using parameters PD02 to PD09 or PD21 to PD24.

0	0	0	x
---	---	---	---

x=0: Invalid

x=1: The external CDP signal of DI is ON

x=2: Position command frequency is equal to higher than parameter CDS setting

x=3: Position command pulse error is equal to higher than parameter CDS setting

x=4: Motor speed is equal to higher than parameter CDS setting

x=5: The external CDP signal of DI is OFF

x=6: Position command frequency is equal to lower than parameter CDS setting

x=7: Position command pulse error is equal to lower than parameter CDS setting

x=8: Motor speed is equal to lower than parameter CDS setting

(3) Gain switch condition value CDS (PB12)

The value of gain switch condition (kpps · pulse · rpm) is changed by the setting of CDP(PB11). When the setting value is 0002, this parameter unit is frequency (kpps); when the setting value is 0003, this parameter unit is pulse; when the setting value is 0004, this parameter unit is torque (rpm). The unit will vary according to the setting value of switching conditions.

PB11 setting value	Gain switch condition	Unit
0002	Position command frequency is equal to higher than parameter CDS setting	kpps
0003	Position command pulse error is equal to higher than parameter CDS setting	pulse
0004	Motor speed is equal to higher than parameter CDS setting	rpm
0006	Position command frequency is equal to lower than parameter CDS setting	kpps
0007	Position command pulse error is equal to lower than parameter CDS setting	pulse
0008	Motor speed is equal to lower than parameter CDS setting	rpm

(4) Gain switch time constant CDT (PB13)

Switching time constant is used for the change of smoothing gain, which is used to set up the time constant of switching CDP and CDS. When the gain set too large, use this parameter to set the mechanical vibration can be slowed down.

(5) The ratio 2 of load inertia to motor shaft GD2 (PB14)

Enable to set to change the ratio of load inertia to motor shaft and if the ratio of load inertia to motor shaft does not change, please set this parameter to the value of GD1 (PB06).

(6) The change rate PG2、VG2、VIC2 (PB15~PB17) when position gain 2、speed gain 2、speed integral gain switch. The original servo gain value would correct to the ratios (%) set by PG2, VG2, and VIC to run gain switching.

Example 1: The external DI signal as the switch option.

Relevant parameters setting:

Name	Name Abbr.	Sign	Setting value	Unit
The ratio of load inertia to motor shaft	GD1	PB06	70	0.1time
Position loop gain	PG1	PB07	100	rad/s
Speed loop gain	VG1	PB08	500	rad/s
Speed integral gain	VIC	PB09	100	ms
Gain switch option	CDP	PB11	0001	-
Gain switch time constant	CDT	PB13	10	ms
The ratio 2 of load inertia to motor shaft	GD2	PB14	20	0.1time
Position loop gain change ratio	PG2	PB15	80	%
Speed loop gain change ratio	VG2	PB16	120	%
Speed integral gain change ratio	VIC2	PB17	150	%

The sequence of gain switch:

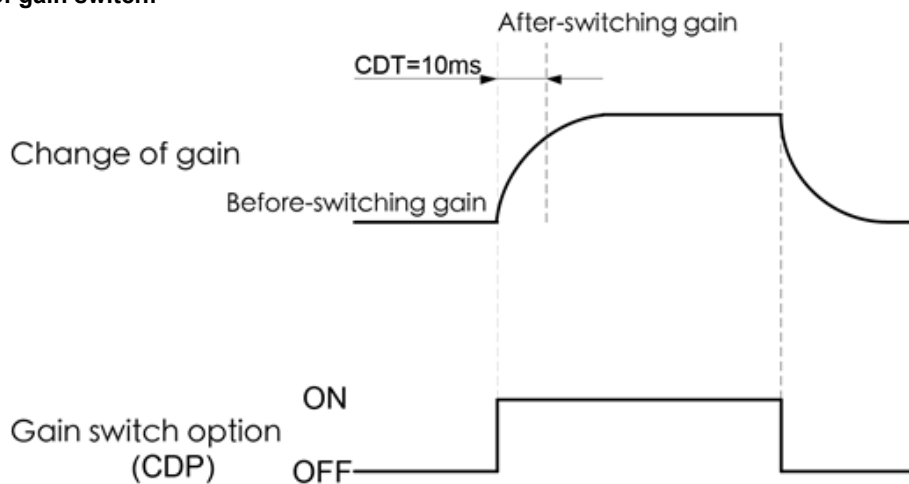

The states of parameters change:

Name	CDP OFF	CDP ON	CDP OFF
The ratio of load inertia to motor shaft	10	→ 20	→ 10
Position loop gain	100	→ 80	→ 100
Speed loop gain	500	→ 600	→ 500
Speed integral gain	100	→ 150	→ 100

Example 2: Trigger condition of position command pulse error.

Relevant parameters setting:

Name	Name Abbr.	Sign	Setting value	Unit
The ratio of load inertia to motor shaft	GD1	PB 06	10	0.1time
Position loop gain	PG1	PB07	100	rad/s
Speed loop gain	VG1	PB08	500	rad/s
Speed integral gain	VIC	PB09	100	ms
Gain switch option	CDP	PB11	0003	-
Gain switch condition value	CDS	PB12	100	pulse
Gain switch time constant	CDT	PB13	10	ms
The ratio 2 of load inertia to motor shaft	GD2	PB14	20	0.1time
Position loop gain change ratio	PG2	PB15	80	%
Speed loop gain change ratio	VG2	PB16	120	%
Speed integral gain change ratio	VIC2	PB17	150	%

The sequence of gain switch:

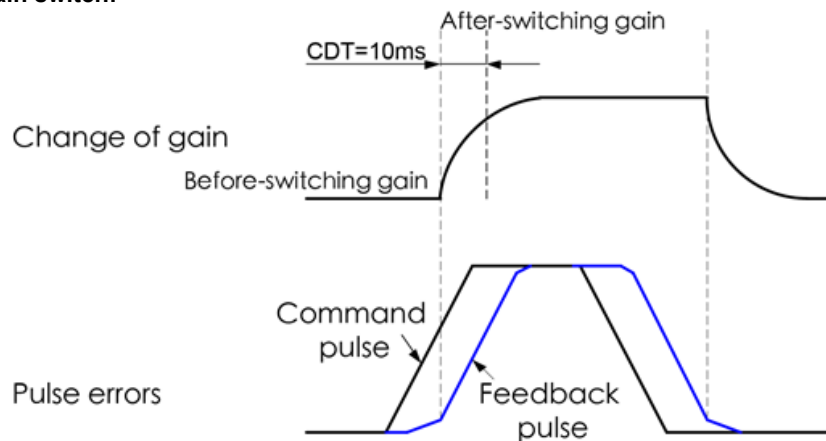

The states of parameters change:

Name	CDP OFF	CDP ON	CDP OFF
The ratio of load inertia to motor shaft	10	→ 20	→ 10
Position loop gain	100	→ 80	→ 100
Speed loop gain	500	→ 600	→ 500
Speed integral gain	100	→ 150	→ 100

6.4 Position control mode

This mode is used at occasions, for example, machine tool, CNC processing, where require highly accurate positioning. There are two ways for position command: one is the external input and the other is internal register input. The external input is to receive the external pulse-train commands. The inner register input enables users to use the inner 63 sets of registers as the position commands (refer to the chapter 7) and then set the DI function of POS1 to PO3 to switch the corresponding position command. The following table explains the settings of the external input and inner register input.

Name	Name Abbr.	Sign	Setting range	unit	Initial value	Control mode	Description				
Control mode option	STY	PA01 (*)	0000h ~ 1115h	-	0000h	ALL	Setting value of Control mode option: <table border="1" style="display: inline-table; vertical-align: middle;"> <tr> <td>u</td> <td>z</td> <td>y</td> <td>x</td> </tr> </table> x:control mode select x=0:position <u>y:position command select</u> y=0:external input y=1:inner register	u	z	y	x
u	z	y	x								

The modification of PA01 would be valid by power off once and power on again.

► The S-pattern smooth is invalid as the external pulse-train commands are applied.

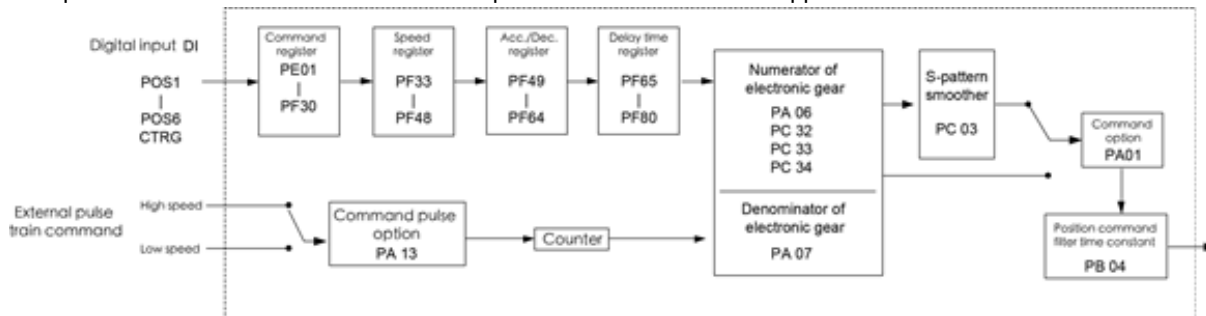

6.4.1 External pulse-train command (Pt Command)

Name	Name Abbr.	Sign	Setting range	unit	Initial value	Control mode	Description
Function selection 3 (Command pulse option)	PLSS	PA13	0000h ~ 1112h	-	0000h	Pt	<p>Setting external pulse-train command</p> <p><u>u</u> <u>z</u> <u>y</u> <u>x</u></p> <p>x: Setting value of Control mode option: x=0: Forward/reverse rotation pulse train x=1: Pulse train + sign x=2: A/B phase pulse train</p> <p>y: acknowledged logic y=0: positive logic; y=1: negative logic</p> <p>z: Setting of pulse filter when u=0, the setting of z means : z=0: below 500KPPS z=1: below 200KPPS when u=1, the setting of z means z=0: below 4000KPPS z=1: below 1000KPPS</p> <p>u: External pulse source options u=0: low speed optical coupler (CN1pin, PP, PG, NP, NG) u=1: high speed differential signal (CN1pin, HPP, HPG, HNP, HNG)</p>

The position commands are provided by external devices. When this mode applied, set the PA01 as 0000. There are 3 formats which could be used by users. The pulse trigger could be assigned into positive or negative logic. Positive logic means that the drive recognizes the pulse valid by the rising edge. On the other hand, negative logic means the falling edge.

Related parameter is listed below. The PA13 would be valid by power off once and power on again.

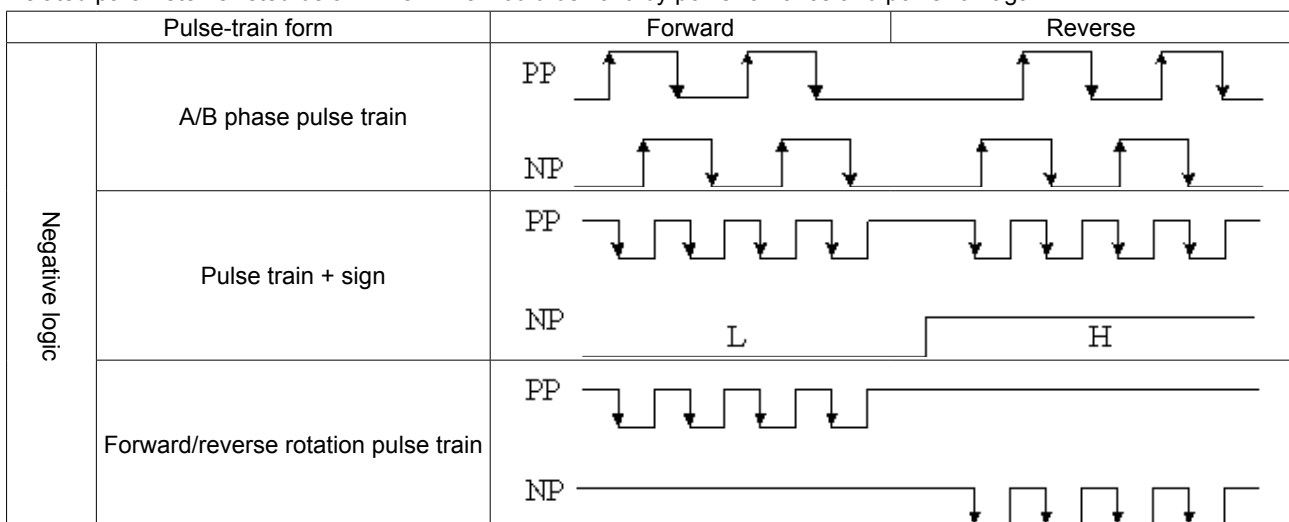

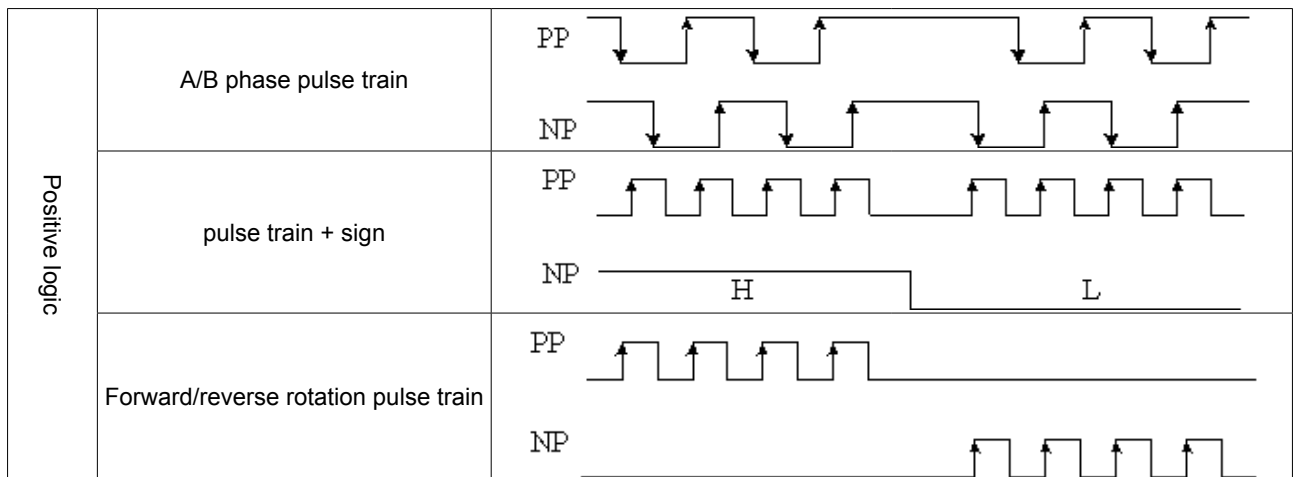

If pulse train is line drive type, the highest permissible frequency is 500Kpps. If pulse train is open collector type, the highest permissible frequency is 200Kpps.

6.4.2 Inner register command (Pr Command)

Please refer to chapter 7 for details.

PR command uses parameter PE01 to PE98 and PF01 to PF30 form 64 sets of inner command registers and with external I/O (CN1 \ POS1 ~ POS6 \ CTRG) which could select one set of 64 sets as position command, as the following table :

There are two ways for position command: one is the external input and the other is internal register input. The external input is to receive the external pulse-train commands. The inner register input enables users to use the inner 63 sets of registers as the position commands (refer to the chapter 7) and then set the DI function of POS1 to POS3 to switch the corresponding position command. The following table explains the settings of the external input and inner register input.

Command	POS6	POS5	POS4	POS3	POS2	POS1	CTRG	Corresponding parameter
PO	0	0	0	0	0	0	↑	PE01 PE02
P1	0	0	0	0	0	1	↑	PE03 PE04
~								~
P50	1	1	0	0	0	1	↑	PF03 PF04
P51	1	1	0	0	1	1	↑	PF05 PF06
~								~
P63	1	1	1	1	1	1	↑	PF29 PF30

POS1 ~ POS6 status : 0 means short-circuit (Open), 1 means open-circuit (Close)

CTRG : means the transient of short-circuit (0) to open-circuit (1).

The applications of absolute/incremental command are common that equal to a simple program control. Users could use the table above to complete the periodical operation easily.

Absolute/incremental position command :

The applications of absolute/incremental command are common. Users have to make PA01 valid then use these two types. See the table below for parameter setup.

Name	Name Abbr.	Sign	Setting range	unit	Initial value	Control mode	Description				
Control mode option	STY	PA 01	0000h ~ 1115h	-	0000h	ALL	<table border="1" style="display: inline-table; margin-bottom: 5px;"> <tr> <td>u</td> <td>z</td> <td>y</td> <td>x</td> </tr> </table> x=0:position control mode y=1:inner register(absolute type) y=2:inner register(incremental type)	u	z	y	x
u	z	y	x								

For example, enter the position register P1 and P2 to 30 turns and 60 turns, send P1 commands and then send P2 command.

The results of absolute and incremental type even the same sequent of commands are listed.

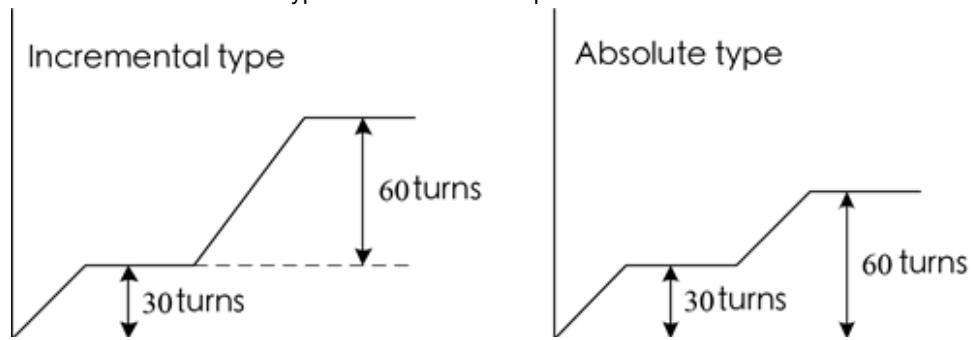

6.4.3 Position command smoothing

This is used to smooth the running of motor as a violent position command change is applied.

Name	Name Abbr.	Setting range	Unit	Initial value	Control mode
Position command filter time constant	PB 04	0~20000	ms	3	Pt · Pr

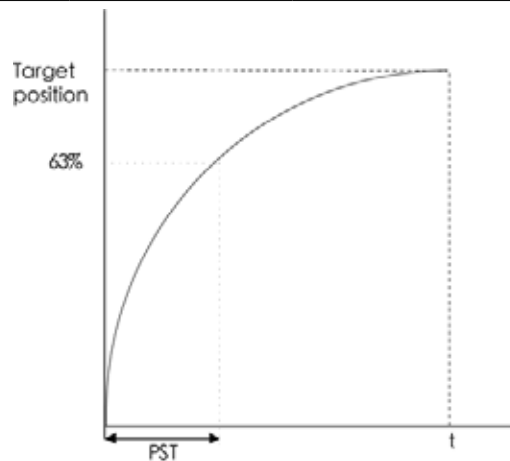

In addition, users can also use the acceleration/deceleration speed smoothing, to let the servo motor run more smoothly. Acceleration/deceleration speed smoothing parameters are shown as the following table:

Name	Sign	Name Abbr.	Setting range	Unit	Initial value	Control mode
S-pattern smoothing	STC	PC 03	0~10000	ms	0	Pr · S · T

Note: Please refer to chapter 7 for the acceleration/deceleration time of PR mode

► It is recommending turning on the PC03 function.

To use the S-pattern smoothing could improve the acceleration/deceleration vibration. The load inertia ratio increased or occasion with huge inertia change may cause a motor rough running. In this case, users could use the STC (PC03) to improve the phenomenon.

When the external pulse-train position command is applied, the STA (PC01), STB (PC02), STC (PC03) would be invalid. This is because the speed and acceleration continuity of the external pulse commands was determined by the host controller.

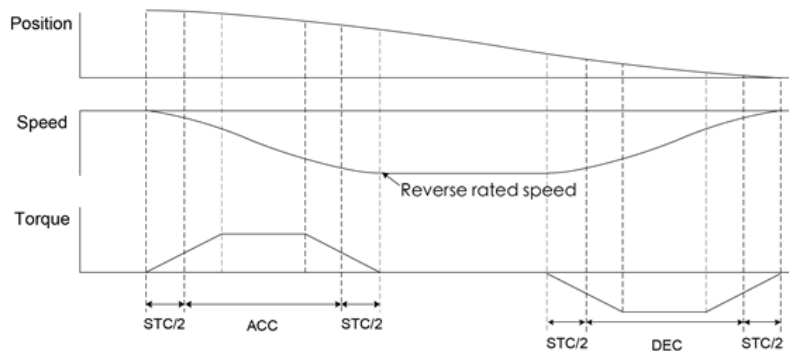
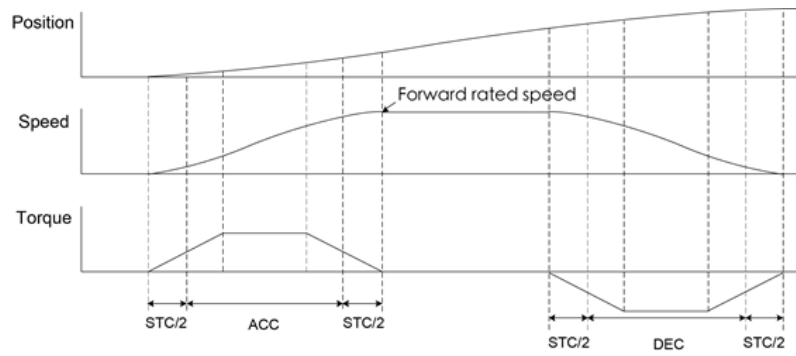

As a forward/reverse rotation due to position command is done, the acceleration/deceleration time is decided by the PF49~PF64.

As the inner register command is applied, it is recommended to use the S-pattern smoothing.

Note: The setting of ACC and DEC, please refer to the chapter 7.

6.4.4 Electronic gear ratio

Users could set different electronic gear ratios to enable the transmission mechanism to move different distances. Relevant parameters are presented below.

Name	Name Abbr.	Sign	Setting range	Unit	Initial Value	Control mode
Electronic gear numerator	CMX	PA 06	1~1048576	-	1	Pt · Pr
Electronic gear denominator	CDV	PA 07	1~1048576	-	1	Pt · Pr
Electronic gear numerator 2	CMX2	PC 32	1~1048576	-	1	Pt · Pr
Electronic gear numerator 3	CMX3	PC 33	1~1048576	-	1	Pt · Pr
Electronic gear numerator 4	CMX4	PC 34	1~1048576	-	1	Pt · Pr

The improper setting could lead to unexpected fast rotation so make sure to set them in the state of SERVO OFF.

The range of the electronic gear ratio is $1/50 < (CMX/CDV) < 25600$. If the setting value is outside this range, the operation of motor may not be performed. The relationship of electronic gear numerator and electronic gear denominator is plotted below.

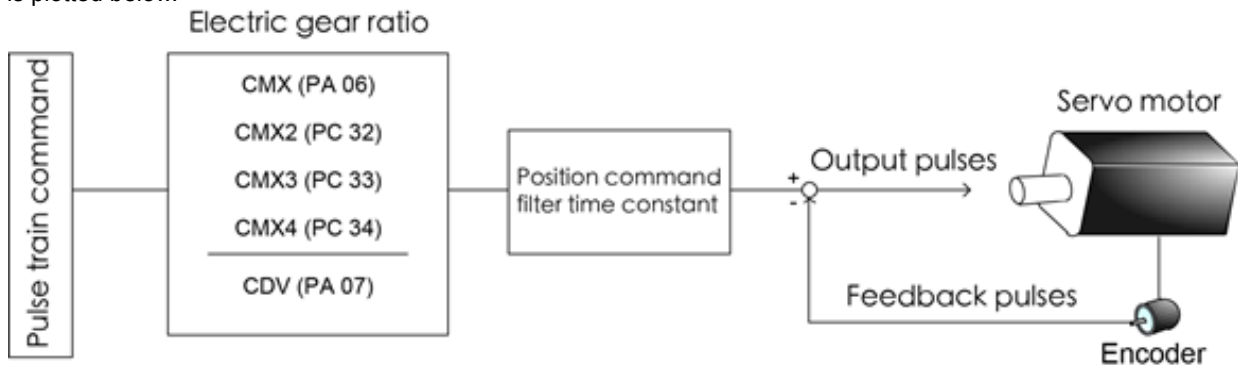

4 electronic gear numerators are available for users to select. Enable the function CM1 and CM2 of DI to switch. See the table below.

Name	CM1	CM2	Control mode
Electronic gear numerator 1 (PA 06)	0	0	Pt、Pr
Electronic gear numerator 2 (PC 32)	1	0	Pt、Pr
Electronic gear numerator 3 (PC 33)	0	1	Pt、Pr
Electronic gear numerator 4 (PC 34)	1	1	Pt、Pr

0: OFF (CMx-SG is open-circuit), 1:ON (CMx-SG is short-circuit), x=1, 2

Calculation of electronic gear ratio:

Before calculating the value, users have to know the specifications such as the resolution of motor encoder (22bit Pulse/rev), the deceleration rate, and the gear ratio of the machine. Use the following equation to calculate the electronic gear ratio.

$$\text{Electronic gear ratio} = \frac{\text{Encoder resolution}}{\text{Load distance per revolution(angle)/Distance pulses to be shifted entered by users}}$$

If a gear ratio between motor and loads existed, to multiply the factor:

The following example explains the method for setting the electronic gear ratio.

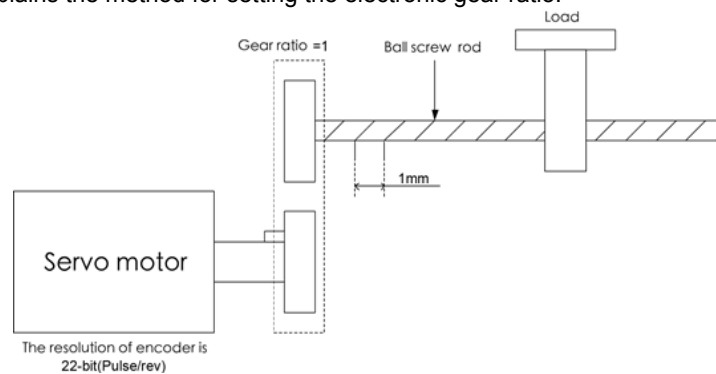

Load distance per revolution is 1mm, the resolution of motor encoder is 22-bitPulse/rev, the gear ratio of load mechanism to motor shaft is 1, if the demand distance is 5µm, the calculation is listed below.

$$\frac{1048576 \text{ pulse / rev}}{1 \text{ mm / rev} \div 5 \mu\text{m / pulse}} = 1048576 / 200$$

From above, it could be known that by setting the electronic gear numerator as 4194304 and the electronic gear denominator as 200, then the ball screw rod would be shift a 5-µm distance after a position pulse command.

6.4.5 Torque limit of position control mode

See section 6.3.4. for details.

6.4.6 Position loop gain

If users need to use manual-gain tuning for position loop, to set parameters of speed loop (see Section 6.3.5) is priority since position loop is outside control of speed loop. Then users could set proportion gain and feed-forward gain of position loop. Usually, position gain is 1/4~1/6 value of the speed loop gain. Users could also use auto-gain tuning mode to set the gains of position and speed loop automatically. Position loop block diagram is presented below.

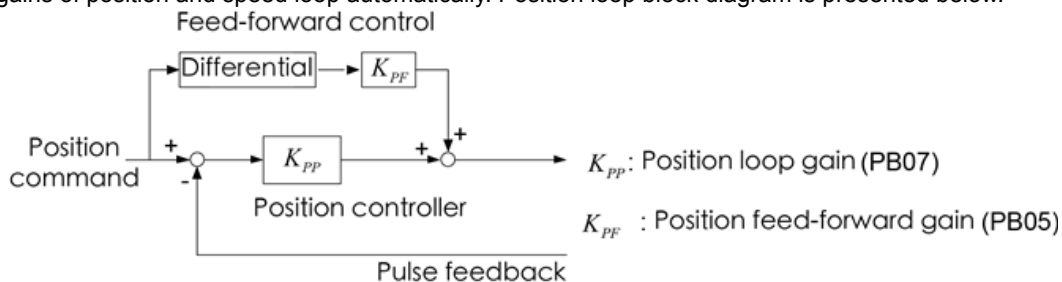

Parameters related to position gain adjustment are listed below.

Name	Name Abbr.	Sign	Setting range	Unit	Initial value	Control mode
Gain tuning mode option	ATUM	PA02	0000h~0003h	-	0002h	Pt、Pr、S、T
Auto-tuning response level setting	ATUL	PA03	1~32	-	10	Pt、Pr、S、T
Position feed-forward gain	FFC	PB05	0~200	%	0	Pt、Pr
Position loop gain	PG1	PB07	4~1024	rad/s	45	Pt、Pr

If position loop gain PG1 (PB07) is set too large, the motor would rotate back and forth and generate vibration even though the bandwidth and response are becoming faster. These phenomena are not permitted for occasions requiring an accurate position control. In this case, be sure to reduce PG1 value to prevent motor vibration. If the bandwidth limited due to mechanism factors causes a bad traceability, position feed-forward gain could be used to reduce the dynamic error of position tracking. On the other hand, the usage of feed-forward control also relatively increases the position settling time.

The method for adjusting position feed-forward gain is to increase the value gradually. Theoretically, 1 is the best setting value. The improper value would cause machine vibration easily. In such case, users should decrease the position feed-forward gain to meet a vibration-free situation.

6.5 Hybrid control mode

The 5 hybrid modes of servo drive could satisfy users who need to change varied modes frequently. The parameter PA01 could be changed for the setting of hybrid mode. See the table below.

Control mode		Abbr.	PA 01 Setting	Description
Hybrid mode	Position with external command - speed	Pt-S	1001h	Via DI signal to switch Pt and S
	Position with external command - torque	Pt-T	1005h	Via DI signal to switch Pt and T
	Position with inner register command - speed	Pr-S	1011h	Via DI signal to switch Pr and S
	Position with inner register command - torque	Pr-T	1015h	Via DI signal to switch Pr and T
	Speed - torque	S-T	1003h	Via DI signal to switch S and T

The arrangement of DI and DO is critical when the hybrid mode is applied. To avoid DI/DO pins insufficient, users could apply external analog voltage signal as the command of speed/torque mode and external pulse train command for position mode so that could reduce the demand of DI.

The function LOP of DI should be made valid as the hybrid mode applied. See the following table.

Name	Sign	I/O	CN1No.	Description	Control mode	
Control mode switch	LOP	DI	CN1-21 (default)	Option of position/speed switched	Described by varied case	
				(Note) LOP		Control mode
				0		position
				1		speed
				Option of speed/torque switched		
				(Note) LOP		Control mode
				0		Speed
				1		Torque
				Option of torque/position switched		
				(Note) LOP		Control mode
0	Torque					
1	position					
Note 0: OFF(LOP-SG is open-circuit), 1: ON(LOP-SG is short-circuit)						

The pin function setting of ST1 and RS2 are the same value, as speed/torque hybrid mode is applied and the LOP signal activated, the ST1 function would have priority in speed control mode and the RS2 function would have priority in torque control mode. Others such as POS1/SP2, PC/ST1, RS2/PC, TL/ST2, ST2/RS1, RS1/TL, and CR/SP1 are defined mutually. The drive would automatically recognize the corresponding DI pin function when 2 different modes are switched. See Section 3.4.2 for more details.

6.5.1 Position/speed hybrid mode

This hybrid mode is divided into 2 types in detail. i.e. Pt/S and Pr/S. The sequence chart of mode switch is presented in the figure below.

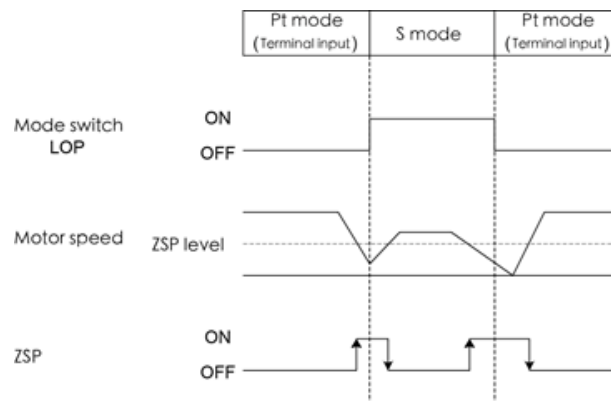

Control mode could not be switched if the motor is at a high speed rotation. It could be performed as the zero speed detection output a signal is ON. Yet it is recommended for users to switch control mode when the motor is stopped completely

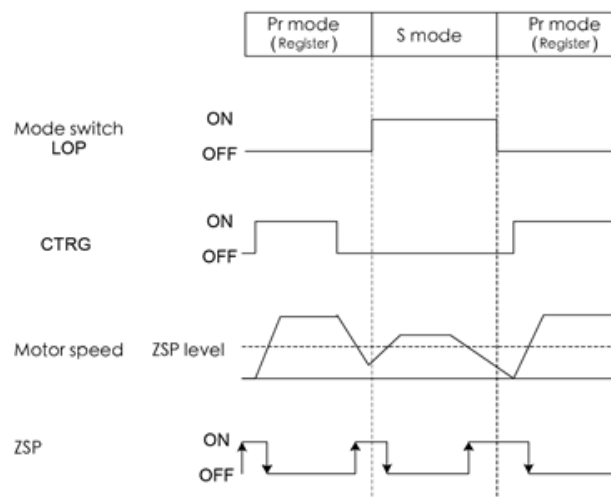

6.5.2 Speed/torque hybrid mode

Set the PA01 as 1003H before this hybrid mode performed. Users could use LOP signal to switch speed mode and torque mode. Because pin function ST1 (ST2) and RS2 (RS1) are defined mutually, the rotation direction of motor would reverse while changing between the speed and torque modes.

The sequence diagram of the speed / torque mode is presented below.

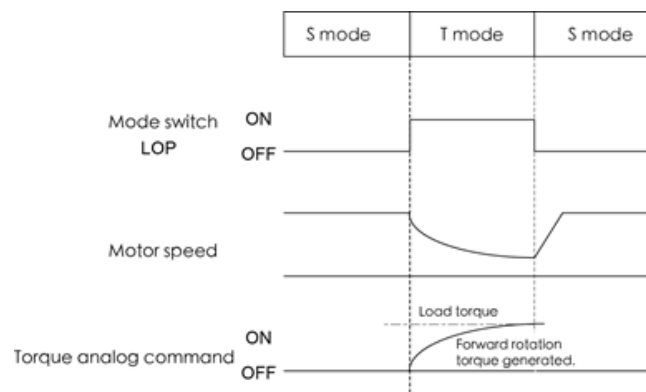

It is recommended that users switch the speed to torque mode after the motor is static.

6.5.3 Torque/Position hybrid mode

This hybrid mode is divided into 2 types in detail. i.e. T/Pt and T/Pr. Users could set the PA01 as 1005 (T/Pt mode) or 1015 (T/Pr mode). The switch could not be performed if the motor is at a high speed rotation. It could be switched as the zero speed detection output signal is ON. Users could use the pin function LOP of DI to switch these 2 modes. When the position mode with inner register command is wanted, the state of CTRG signal must be turned on. The sequence chart is presented in the figure below.

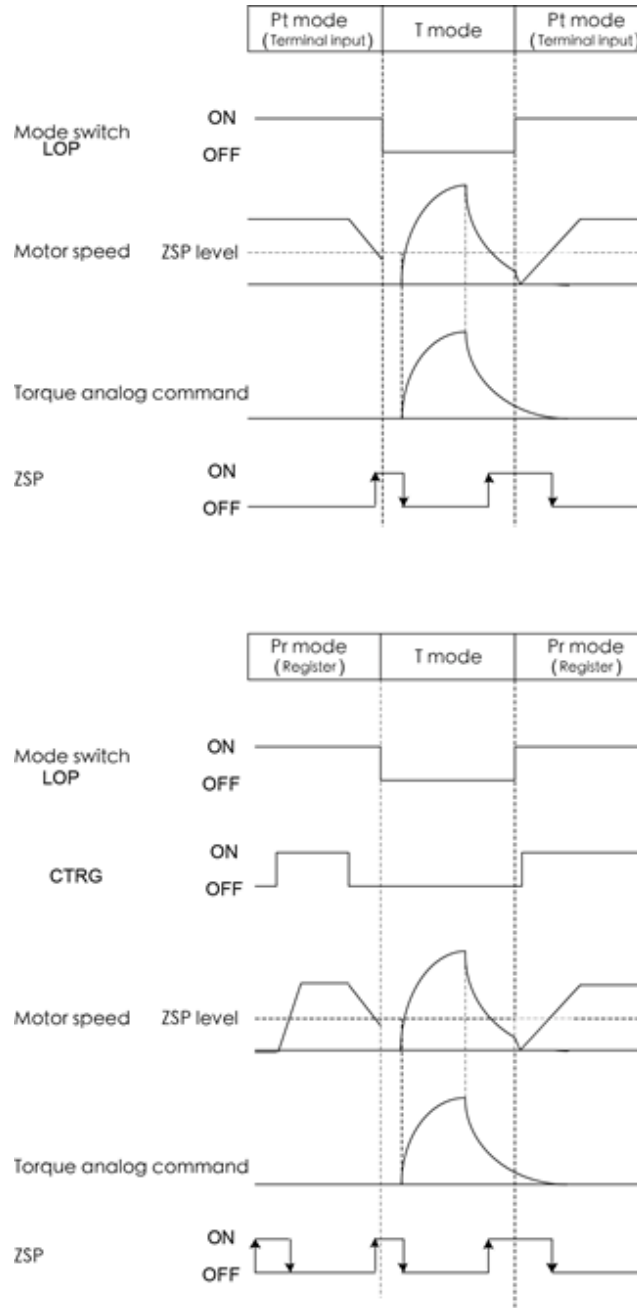

It is recommended that users switch torque to position mode after the motor is static.

6.6 Other functions

⚠ DANGER • Before wiring or inspection, switch power off and wait for more than 10 minutes. Then, confirm if the power indicator is off or the voltage is safe with voltage meter. Otherwise, you may get an electric shock.

⚠ WARNING • Please use the specified peripheral equipment products. Otherwise may cause fire or failure.

6.6.1 Selection of brake resistor

⚠ WARNING • Regenerative resistor and servo drives in addition to the specified combination is not available or it may become a fire hazard.

As the direction of motor generated torque is opposite to the rotary direction of motor, it becomes a power generator. The regenerative energy would be turned back to the servo drive. To prevent from P-N voltage exceeded, a voltage (under 370V) stabilized protection is necessary. The IGBT switch and brake resistors constitute this protection. Regenerative energy is consumed by the brake resistor.

There is a built-in brake resistor inside the drive. If the regenerative energy is too large, it is not recommended to use the one. Instead, use an external one to avoid overheating. When using the built-in brake resistor, make sure that the P-D terminals is short-circuit. If the external brake resistor applied, make P/D terminals open while the external resistor is connected to the P/C terminals.

Built-in brake resistor specifications for Shihlin servo drive are described below.

Drive (W)	Built-in brake resistor specification		Minimum permissible (Ω)	Consumption power of built-in resistor (W)
	resistor (Ω)	Capacity (W)		
100	100	20	100	10
200	100	20	100	10
400	100	20	100	10
500	100	20	100	10
750	40	40	40	20
1000	40	40	40	20
1500	13	100	13	50
2000	13	100	13	50
3500	13	100	13	50
5000	Without Built-in brake resistor		8	Without Built-in brake resistor
7000				

- The average regenerative power that could be consumed is at 50% rated power of the built-in brake resistor. So as the external brake resistor.

As external brake resistor is applied, the same resistance value mentioned above is required. If serial or parallel wiring are applied to increase resistor's power, be sure that the resistance meets the minimum permissible specification. The brake resistor with a thermal switch or a cooling fan would be helpful to tell users that the capacity of brake resistor is insufficient or to reduce the temperature of brake resistor. Please contact the manufacturer of brake resistor to know the detail load characteristic.

In order to let users easily calculate the power of external brake resistor, the calculations are described below.

(a) Without external load

If the motor is repeated running forward and reverse, the braking regenerative energy would return to the aluminum capacitors of servo drive. When the P-N voltage exceeds a particular value, the brake IGBT switch is turn on and the brake resistor would dissipate the regenerative energy. The following statement and table provide the calculation of regenerative power.

Drive (W)	Motor inertia($\times 10^{-4}$ kg·m ²)	Regenerative power which from rated speed to stop without load Es(joule)	Regenerative energy of capacitor Ec(joule)
100	0.055	0.27	8.98
200	0.208	1.03	8.98
400	0.335	1.65	11.02
500	6.59	14.45	11.02
750	1.2	5.92	19.18
1000	12.56	27.55	19.18
1500	18.52	40.62	41.62
2000	38.8	85.10	41.62
3500	74.8	164.05	55.49

5000	84.6	185.93	140.00
7000	121.6	267.25	140.00

The capacity of brake resistor is calculated as follows:

$$\text{Power of brake resistor (Pbr)} \Rightarrow 2 \times ((N+1) \times E_s - E_c) / T$$

N is the ratio of load inertia to motor shaft. T is duty cycle (Defined by users).

If the ratio of load inertia to motor shaft is N, deceleration from 3000rpm to stop; the regenerative energy is $(N + 1) \times E_s$. The brake resistor consumption is $(N + 1) \times E_s - E_c$ joules. Assuming the duty cycle is T second, then the recommend power of brake resistor is $2 \times ((N + 1) \times E_s - E_c) / T$.

The calculation procedure is as follows.

J is motor inertia (Unit:kg·m²); Wr is the maximum speed of operation cycle. (Unit: rpm)

Step	Item	Calculation or procedure
1	Choose the duty cycle T	With user's application to decide the repeat operation cycle.
2	Set motor speed Wr	Panel operation to read/write this value.
3	Set load to motor inertia ratio N	Panel operation to read/write this value. (PA02=0002 valid.)
4	Compute the Es	$E_s = J \times W_r^2 / 182$
5	Compute the Ec	Refer to the previous table
6	Compute the Pbr	$2 \times ((N+1) \times E_s - E_c) / T$

► Example 1

The drive's capacity is 400W, duty cycle T is 0.5 second, revolution speed is 3000 rpm, load to motor inertia ratio is 7, then the necessary power of brake resistor = $2 \times ((7 + 1) \times 85.1 - 11.02) / 0.5 = 8.72W$.

Since these are less than the capacity (20W) of 400W servo drive's built-in brake resistor, users could directly use the built-in brake resistor to consume the regenerative energy.

Note: Due to 3000rpm is the rate speed of 400W servo drive; we could find the Es on the previous table is 1.65 J.

► Example 2

The drive's capacity is 2KW, duty cycle T is 1 second, revolution speed is 1000 rpm, and load to motor inertia ratio is 20. Since the revolution speed 1000rpm is less than the rated speed (2000rpm), we need to compute $E_s = 38.8 \times 0.0001 \times 1000^2 / 182 = 21.3J$, then the necessary power of brake resistor = $2 \times ((20 + 1) \times 21.3 - 41.62) / 1 = 811.36W$. Since these are more than the capacity (50W) of 2KW servo drive's built-in brake resistor, a 1000W brake resistor is recommended.

Generally, if the load to motor inertia ratio is small ($N \leq 5$), the built-in brake resistor is sufficient. If the capacity of brake resistor is too small, the heat accumulated is growing easily and the temperature of brake resistor rises soon. When the temperature is higher than a certain value, the brake resistor will be burn out.

(b) With external load

When the external load torque is greater than motor torque, it makes the servo motor output torque direction is opposite to the rotary direction of servo motor. In this case, the external energy is delivered to the servo drive through the servo motor. The following figure is an example that the motor runs in CCW rotation at constant speed when a sudden external load torque change.

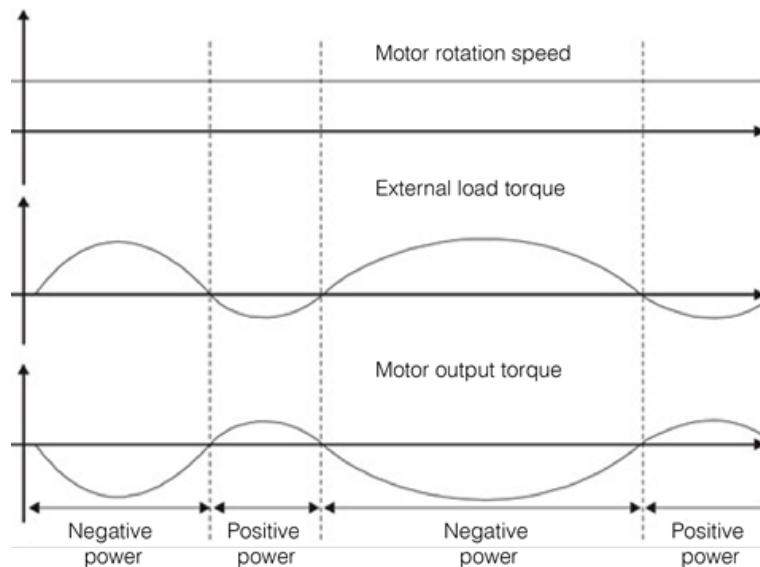

Power of the external load torque (PL) = $T_L \times \omega$

Where:

T_L : is the external load torque. (Unit: Nt-m)

ω : is the motor rotation speed. (Unit: rad/s)

Please calculate this value at safe condition as possible as you can.

If an external load torque of +50% rated torque is applied and the servo motor speed is 3000r/min, the servo drive is 400W capacity(rated torque: 1.27Nt-m), then the users need to connect an external brake resistor which power is $2 \times (0.5 \times 1.27) \times (3000 \times 2 \times \pi / 60) = 399W, 100\Omega$.

Note: 1rpm = $2\pi / 60$ (rad/s)

6.6.2 Analog monitor output

There are 2 analog monitor channels (MON1 · MON2) whose address is in CN1-30(MON1) and CN1-32(MON2) provided for users to check the required signals. The contents and settings of monitor output are described in the table below.

Name	Name Abbr.	Sign	Setting range	Description	Initial value	Control mode				
Analog monitor output	MOD	PC 14	0000h ~ 0707h	There are 2 monitor outputs, ch1 and ch2. <table border="1" style="margin-left: 20px;"> <tr> <td>0</td> <td>ch2</td> <td>0</td> <td>ch1</td> </tr> </table> The setting values and their corresponding output are listed below. 0: Motor speed (scale: $\pm 10V$ /(double rated speed)) 1: Generated torque (scale: $\pm 10V$ /max.torque) 2: Speed command (scale: $\pm 10V$ /(double rated speed)) 3: Effective load ratio (scale: $\pm 10V/\pm 300\%$) 4: Pulse command frequency (scale: $\pm 10V/500kpps$) 5: Current command (scale: $\pm 10V$ /max.current command) 6: DC Bus voltage (scale: $\pm 10V/400V$) 7: Pulse command error (scale: $\pm 10V/1048576$ pulse)	0	ch2	0	ch1	0100h	ALL
0	ch2	0	ch1							

Example:

If the PC14 is set as 0000 and the current speed of motor is forward rotation ± 3000 rpm (\pm means forward/reserve rotation), a +5V signal would be measured on CN1-30. The mentioned example above is without any adjustment of PC28 to PC31.

Voltage offset of analog monitor

The parameter PC28 and PC29 are used to set the compensation to eliminate the bias voltages of analog monitor output MON1 and MON2. Description as followings.

Name	Name Abbr.	Sign	Setting range	Description	Unit	Initial value	Control mode
Analog monitor MO1 offset	MO1	PC 28	-999 ~ 999	Used to set the offset voltage of the analog monitor MO 1 output.	mV	0	ALL
Analog monitor MO2 offset	MO2	PC 29	-999 ~ 999	Used to set the offset voltage of the analog monitor MO 2 output.	mV	0	ALL

Here is an example.

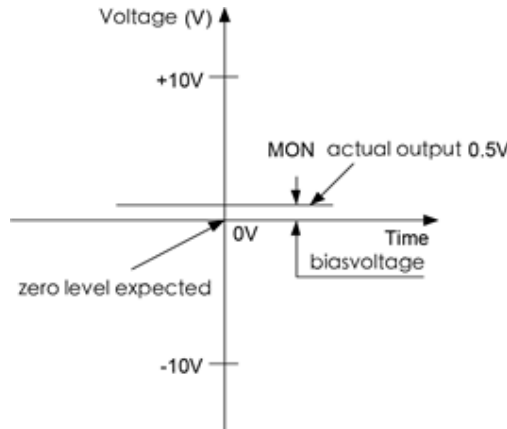

It assumes that the motor speed is 0 rpm and then the analog monitor voltage output should be 0 V. This difference above is 0.5 V, which could be compensated by setting PC28 or PC29 as -500mV so the MOD analog voltage would be corrected.

Output proportion of analog monitor

The output proportion of analog monitor enables users to set the ratio of the analog voltage output to be viewed. Relevant parameters are presented in the table below.

Name	Name Abbr.	Sign	Setting range	Description	Unit	Initial value	Control mode
Analog monitor MON1 output proportion	MOG1	PC30	0~100	Set the output proportion of analog monitor MON 1.	%	100	ALL
Analog monitor MON2 output proportion	MOG2	PC31	0~100	Set the output proportion of analog monitor MON 2.	%	100	ALL

If the current rotation speed is ±3000 rpm and monitor scale is ±10V/ (double rated speed), the analog output should be +5V if MOG1 or MOG2 is set as initial value (100%). So, the analog monitor output voltage by MON should be +10V in case of 50% setting value applied.

The equation is:

$$\text{MOD output voltage} = \frac{\text{Current monitor value}}{\text{Maxiumu monitor value}} \times 10V \div \text{MOG}$$

MOG1/ MOG2 unit: %

6.6.3 Operation of electromagnetic brake interlock

The electromagnetic brake interlock signal is described:

- (1) As MBR is OFF, the electromagnetic brake is disabled and motor shaft is locked.
- (2) As MBR is ON, the electromagnetic brake is enabled and motor shaft is rotatable.

The PC16 could be used to decide the delay time of SON signal off to MBR signal activated. The electromagnetic brake is usually applied on the Z axis (vertical axis) prevents from load falling.

Electromagnetic brakes normally used on the z axis (vertical axis) direction to lower servo motor 's resistance that produces overheat which would result in the decreasing of motor cycle life. Electromagnetic brake must be operated in the servo OFF situation. Brake signal can control brake to be magnetic; provide electromagnetic brake power, and make electromagnetic brake open.

- MBR enables/disables magnetic contactor to release/lock the motor shaft.
- The coil of electromagnetic brake is without polarity.
- Do not use CN1_48 (+24Vdd) to drive the electromagnetic brake.
- If users control the electromagnetic brake without MBR DO, refer to the operation sequence.
- If want to turn on the function of DO MBR, please set the PA01 to X1XX.

The operation sequence of electromagnetic brake is plotted below.

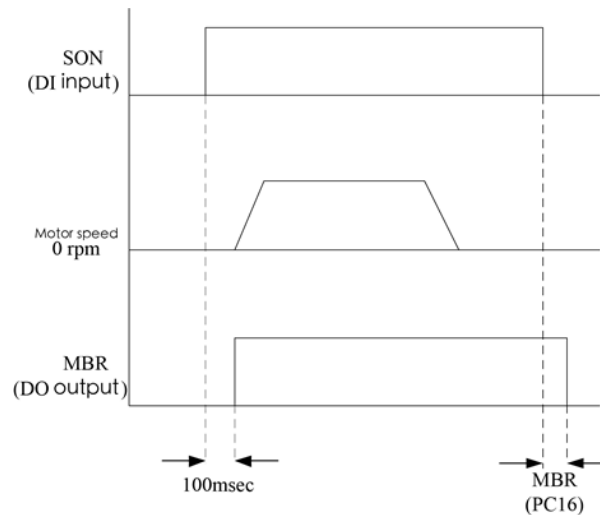

Wiring diagram of electromagnetic brake (MBR DO applied)

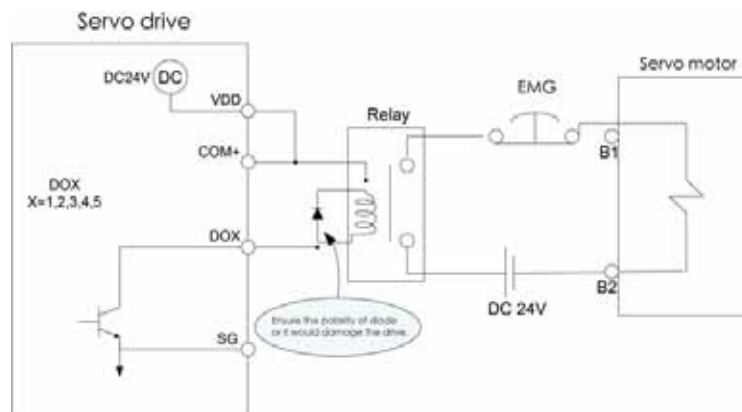

Specification of electromagnetic brake:

Motor type	SMA series				
	L010B	L020B/L040B	L075B	M050B/M100B/M150B	M200B/M350B M500B/M700B
Brake type	Spring brake (Normal locked)				
Rated voltage (V)	DC 24V				
Rated power (W)	6.3	7.9	8.6	19.3	34
Rated current (A)	0.24	0.32	0.35	0.8	1.41
Friction Tq (N·m)	0.3	1.3	2.4	8.5	45

Electromagnetic brake is only provided for security of stopped motor, please don't use at motor deceleration.

7. PR (Procedure) Procedure control function description

7.1 Pr mode description

PR (Procedure): PR Procedure is the minimum unit of command in PR mode. A command is composed by one procedure or many procedures and there are 64 sets of procedure which are plan able consist of one home returning procedure and 63 sets PR procedure.

There are three types of procedure trigger as followings :

Standard triggering : Assigned to trigger procedure by POS1 to POS6 and triggered by CTRG↑.

Event triggering : Trigger procedure by rising edge and falling edge of EV1~EV4, please refer to the parameter setting of PF83 and PF84.

Software triggering : Write the trigger No. to PF82 when servo ON.

7.2 The difference of PR mode between SDH and SDA

	PR mode of SDA	PR mode of SDH
Total amount of command	8 section isolated position	1 home returning procedure (PR#0) 63 sets PR procedure (PR#01~PR#63)
Total type of command	In-Position command	In-Position/ Constant speed /JUMP/WRITE/index position
Position command	Absolute / relative alternative	Absolute/incremental/relative (used interchangeably)
Acceleration / deceleration time	1 set	16 sets
Moving speed	8 sets	16 sets
Delay time	-	16 sets
Command trigger type	DI: POSn + TRG↑	DI: POSn + CTRG↑ Event triggering : EV1~EV4 Software triggering : PF82
Position command format	turns · pulses	32 byte data (varied by control mode)
Home returning	Auto trigger when power on. (The first SON) trigger by DI:SHOM	Auto trigger when power on. (The first SON) trigger by DI:SHOM Procedure 0(PR#0) is home returning. After home return, operate assigned procedure automatically.
Soft limit protection	No	Yes

7.3 DI/DO and timing of PR mode

DI signal:

CTRG · SHOM · STOP · POS1~POS6 · ORGP · LSP · LSN · EV1~EV4

DO Signal:

CMDOK · MC_OK · INP (In-position range) · ALM · OVF (Position overflow) · SWPL (Software positive limit output) · SWNL (Software negative limit output)

INP · CMDOK and MC_OK timing chart:

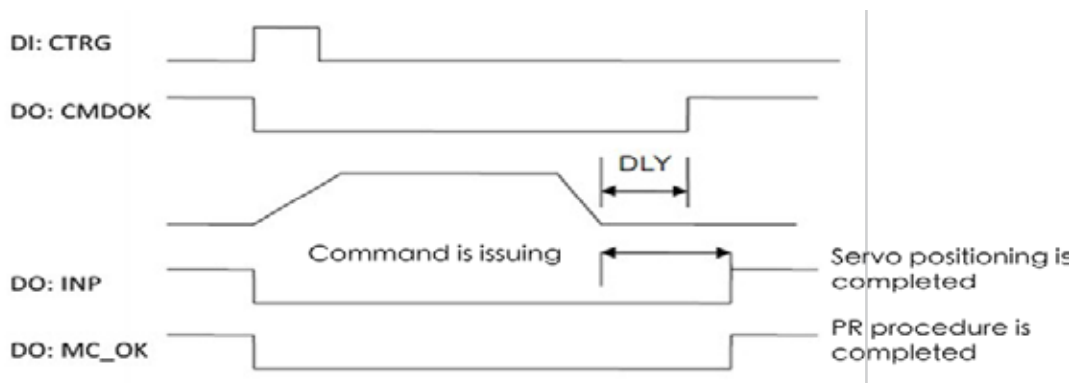

Command trigger description of PR mode :

	Command source	Description
Standard triggering	DI: CTRG↑+POS1~6	The usage of DI: POS1~6 assigned procedure NO. which wants to be triggered and then trigger PR command with the rising edge of DI: CTRG. Application: DI command of PC or PLC.
Specialized triggering	DI: STOP, SHOM	DI: When STOP is from OFF to ON, command stop. DI: When SHOM is from OFF to ON, start to home return.
Event triggering	DI: EV1~EV4	DI: The changed status of EV1~EV4 to be a trigger event. The triggered procedure NO. with setting PF83 from OFF to ON. The triggered procedure NO. with setting PF84 from ON to OFF. Application : connecting sensors trigger the default procedure.
Software triggering	PF82	When servo on, writes procedure NO. directly into PF82 to trigger the procedure. (Panel/communication software can be used) Application : PC command by communication method

7.4 Parameter setting of PR mode

Target speed : PF33 ~ PF48, total 16 sets.

	15~0 BIT
PF33~PF48	Target speed: 1 ~ 3000 (rpm)

Acceleration / deceleration time : PF49 ~ PF64, total 16 sets.

	15~0 BIT
PF49~PF64	Acceleration / deceleration time constant: 1 ~ 65500 (ms)

Delay time : PF65 ~ PF80, total 16 sets.

	15~0 BIT
PF49~PF64	Delay time: 1 ~ 32767 (ms)

Relevant parameters of PR mode :

	Function description
PA04	Home moving option
PA08	Home moving high speed option 1
PA09	Home moving low speed option 2
PE01	Origin return path definition
PE02	Origin Data value
PF81	Auto-protection of deceleration time
PF82	PR command trigger registers(Soft trigger)
PF86	Soft limit: Positive
PF87	Soft limit: Negative
PE03~PE98	PR#01~PR#48 path parameter setting
PF01~PF30	PR#49~PR#63 path parameter setting

PR procedure path definition :

There are total 126 parameters from PE03 ~ PE98, PF01 ~ PF30 and 63 sets of PR procedure PR # 01 ~ PR # 63 (PR # 01 ~ PR # 63) can be set.

PR # 01 is set by the PE03 and PE04; PR # 02 is set by the PE05 and PE06, PR # 48 is set by the PE97 and PE98, PF # 49 is set by PF01 and PF02; PR # 63 is set by PF29 and PF30 and so on. So that each set of PR procedure has two parameters to be set.

Take an example of parameter PE03 and PE04 of PR # 01, the setting method of remaining procedures are the same as the example.

The first parameter of each PR procedure is the function setting parameter; the second parameter is the data setting parameter.

The definition of function setting parameter was shown as following table :(PR # 01, for example)

	31~28	27~24	23~20	19~16	15~12	11~8	7~4	3~0 BIT
PE03	-	-	-	-	-	-	-	TYPE
PE04	DATA(32bit)							

The path format and function is determined by TYPE. Here is the definition :

TYPE=1 means constant speed control; TYPE=2 means in-position control; TYPE=3 means AUTO in-position control; TYPE=7 means procedure jump; TYPE=8 means parameter write in; TYPE=A means index position control. Although TYPE=2 and TYPE=3 all mean in-position control, but the difference of them is that TYPE=3 could operate next procedure automatically. Therefore there are five types of control modes which are constant speed 、 in-position 、 procedure jump 、 parameter write in and index position.

SPEED constant speed (TYPE=1): The parameter definition is shown as the table below. (Take PR#01 for an example)

	31~28	27~24	23~20	19~16	15~12	11~8	7~4	3~0 BIT
PE03	x	x	DLY	x	DEC	ACC	OPT	1
PE04	DATA(32bit): Target speed (UNIT could be set from OPT option)							

※When this command is executed, the current speed (not necessarily 0) will start to accelerate or decelerate. Once reaches the target speed, this command is completed and do continuously output without stop.

The definition of OPT option is shown as below :

OPT option			
Bit 7 (0/8)	Bit 6 (0/4)	Bit 5 (0/2)	Bit 4 (0/1)
x	UNIT (unit)	AUTO (Auto operation)	INS (Insert)

※DI: STOP and soft limit are acceptable.

INS: When setting as INS, then the path insert to interrupt the previous path.

AUTO: When speed reaches the area of constant speed, load to next path.

UNIT: When Bit 6=0, the unit is 0.1 rpm; when Bit 6=1, the unit is PPS (Pulse per Second)

ACC/DEC: The range of value is 0~F. Enable to set acceleration and deceleration time NO.

The definition is shown below.

ACC/DEC value	F	E	D	C	B	...	4	3	2	1	0
Corresponding parameter	PF64	PF65	PF64	PF63	PF62	...	PF53	PF52	PF51	PF50	PF49

DLY: The range of value is 0~F. Enable to set delay time NO. The definition is shown below.

DLY value	F	E	D	C	B	...	4	3	2	1	0
Corresponding parameter	PF80	PF79	PF78	PF77	PF76	...	PF69	PF68	PF67	PF66	PF65

POSITION position control: TYPE=2 means complete and stop; TYPE=3 means complete and operate the next path. (Take PR#01 of an example)

	31~28	27~24	23~20	19~16	15~12	11~8	7~4	3~0 BIT
PE03	x	x	DLY	SPD	DEC	ACC	OPT	2 or 3
PE04	DATA(32bit): Target position, unit: pulse							

The definition of OPT option is shown below :

OPT option			
Bit 7 (0/8)	Bit 6 (0/4)	Bit 5 (0/2)	Bit 4 (0/1)
CMD (Command type)		OVLP (Overlapping)	INS (Insert)
CMD option			
BIT 7	BIT 6	Description	
0	0	Absolute position command (Position command=DATA)	
0	1	Relative position command (Position command=Current feedback+DATA)	
1	0	Incremental position command(Position command=The end of previous command+DATA)	

※DI: STOP and soft limit is acceptable.

INS: When setting as INS, then the path insert to interrupt the previous path.

OVLP: The next path overlap is permitted. When the path overlapped, please set DLY to 0.

CMD: The calculation of position command end which is shown as above table.

ACC/DEC: The range of value is 0~F. Enable to set acceleration and deceleration time NO.

The definition is shown below.

ACC/DEC Value	F	E	D	C	B	...	4	3	2	1	0
Corresponding parameter	PF64	PF65	PF64	PF63	PF62	...	PF53	PF52	PF51	PF50	PF49

SPD: The range of value is 0~F. Enable to set target speed NO.
The definition is shown below.

SPD Value	F	E	D	C	B	...	4	3	2	1	0
Corresponding parameter	PF48	PF47	PF46	PF45	PF44	...	PF37	PF36	PF35	PF34	PF33

DLY: The range of value is 0~F. Enable to set delay time NO.
The definition is shown below.

DLY Value	F	E	D	C	B	...	4	3	2	1	0
Corresponding parameter	PF80	PF79	PF78	PF77	PF76	...	PF69	PF68	PF67	PF66	PF65

Procedure jump: TYPE=7 means enable to jump to the assigned PR procedure NO. (Take PR#01 of an example)

	31~28	27~24	23~20	19~16	15~12	11~8	7~4	3~0 BIT
PE03	x	x	DLY	x	x	x	OPT	7
PE04	PATH_NO: Assigned PR procedure NO.; The range is from 0 to 63.							

PATH_NO: Jumped target procedure NO.

The definition of OPT option is shown below :

OPT option			
Bit 7 (0/8)	Bit 6 (0/4)	Bit 5 (0/2)	Bit 4 (0/1)
x	x	x	INS (Insert)

INS: When setting as INS, then the path insert to interrupt the previous path.

DLY: The range of value is 0~F. Enable to set delay time NO.
The definition is shown below.

DLY Value	F	E	D	C	B	...	4	3	2	1	0
Corresponding parameter	PF80	PF79	PF78	PF77	PF76	...	PF69	PF68	PF67	PF66	PF65

Parameter writes in: TYPE=8 means enable to write in the assigned parameter. (Take PR#01 of an example)

	31~28	27~24	23~20	19~16	15~12	11~8	7~4	3~0 BIT
PE03	x	SOUR	DLY	Target parameter be written			OPT	8
PE04	Source (Constant value or parameter NO.)							

The definition of OPT option is shown below :

OPT option			
Bit 7 (0/8)	Bit 6 (0/4)	Bit 5 (0/2)	Bit 4 (0/1)
x	ROM (write in ROM)	AUTO (Auto run)	INS (Insert)

INS: When setting as INS, then the path insert to interrupt the previous path.

AUTO: When speed reaches the area of constant speed, load to next path.

ROM: When Bit 6=0, the parameter would not be written in EEPROM; When Bit 6=1, the parameter would be written in EEPROM.

Writing target parameter: Enable to set the group and NO. of written parameter.

Writing Target parameter		
Bit 16~19	Bit 12~15	Bit 11~8
Parameter group A→1 B→2 C→3 D→4 E→5 F→6	Parameter NO.(Decimal) P□05→05 P□45→45 P□98→98 P□77→77	

(Example : If the target parameter which wants to be written is PF34, please set to 634.)

DLY: The range of value is 0~F. Enable to set delay time NO.
The definition is shown below.

DLY Value	F	E	D	C	B	...	4	3	2	1	0
Corresponding parameter	PF80	PF79	PF78	PF77	PF76	...	PF69	PF68	PF67	PF66	PF65

SOUR: The setting of data source. There are two types of data source setting, one is 'constant write in' and the other is 'parameter value write in'.

SOUR option				Description	
Bit 27	Bit 26 (SOUR)	Bit 25	Bit 24	Data source	Writing purpose
x	0	x	x	Constant	P□XX
x	1	x	x	P□XX	P□XX

□: The group of parameter (A~F) XX: Parameter NO.

Source: There are different definitions according to SOUR setting. The definition is shown below.

Source								
	31~28	27~24	23~20	19~16	15~12	11~8	7~4	3~0 bit
SOUR =0	Constant							
SOUR =1	Rsvd (0x00000)					P_Grp	P_idx	

P_Grp, P_idx: The group and NO. of the source parameter in the function of write parameter.

Constant: Constant data which want to be written in.

When the written value is out of parameter range, then display AL63; When P_Grp is out of range, then display AL61; When P_idx is out of range, then display AL62. When some part of parameters couldn't written in SERVO ON, then display AL.64.

PR will not be executed after AUTO.

Indexing Positioning (Indexing): TYPE = A could apply turret magazine.

(Take PR#01 for an example)

	31~28	27~24	23~20	19~16	15~12	11~8	7~4	3~0 BIT
PE03	x	OPT2	DLY	SPD	DEC	ACC	OPT	A
PE04	DATA (0~4194304): Indexing coordinate command, Unit: pulse							

OPT option			
Bit 7 (0/8)	Bit 6 (0/4)	Bit 5 (0/2)	Bit 4 (0/1)
00: all forward (forward) 01: all backward (reverse) 10: Shortest Path (According to the present position and the target position judgment)		OVLP (Overlapping)	INS (Insert)

The definition of OPT option is shown below :

INS: When setting as INS, then the path insert to interrupt the previous path.

OVLP: The next path overlap is permitted. When the path overlapped, please set DLY to 0.

ACC/DEC: The range of value is 0~F. Enable to set acceleration and deceleration time NO.

The definition is shown below.

ACC/DEC Value	F	E	D	C	B	...	4	3	2	1	0
Corresponding parameter	PF64	PF65	PF64	PF63	PF62	...	PF53	PF52	PF51	PF50	PF49

SPD: The range of value is 0~F. Enable to set target speed NO.

The definition is shown below.

SPD Value	F	E	D	C	B	...	4	3	2	1	0
Corresponding parameter	PF48	PF47	PF46	PF45	PF44	...	PF37	PF36	PF35	PF34	PF33

DLY: The range of value is 0~F. Enable to set delay time NO.

The definition is shown below.

DLY Value	F	E	D	C	B	...	4	3	2	1	0
Corresponding parameter	PF80	PF79	PF78	PF77	PF76	...	PF69	PF68	PF67	PF66	PF65

The definition of OPT2 option is shown below :

OPT2 option			
Bit 27 (0/8)	Bit 26 (0/4)	Bit 25 (0/2)	Bit 24 (0/1)

x	AUTO	x	S_LOW
---	------	---	-------

S_LOW: The selection of speed unit: Bit 24=0 means the speed unit is 0.1 rpm; Bit 24=1 means the speed unit is 0.01 rpm.

AUTO: When the path completed, load to next path automatically.

DATA: Enable to set the coordinate value of each index positioning.

DATA Data format
Pulse: 0~1048575

The definition of home returning: Could be set by PE01 and PE02.

	31~28	27~24	23~20	19~16	15~12	11~8	7~4	3~0 BIT
PE01	BOOT	x	DLY	x	DEC1	ACC	PATH	
PE02	ORG_DEF (32 bit)							

PATH: Enable to set the motion after home returning. The definition of PATH is shown below :

PATH option		
Bit 4~7	Bit 0~3	Description
0	0	Stop after home return
0	1	Perform PR#01 after home return
0	2	Perform PR#02 after home return
~	~	~
3	E	Perform PR#62 after home return
3	F	Perform PR#63 after home return

ACC: The range of value is 0~F. Enable to set acceleration time NO.

The definition is shown below.

ACC Value	F	E	D	C	B	...	4	3	2	1	0
Corresponding parameter	PF64	PF65	PF64	PF63	PF62	...	PF53	PF52	PF51	PF50	PF49

DEC1: The range of value is 0~F. Enable to set the NO of first section deceleration time.

The definition is shown below.

ACC Value	F	E	D	C	B	...	4	3	2	1	0
Corresponding parameter	PF64	PF65	PF64	PF63	PF62	...	PF53	PF52	PF51	PF50	PF49

The second section deceleration time is same as the STP deceleration time of PF81.

DLY: The range of value is 0~F. Enable to set delay time NO.

The definition is shown below.

DLY Value	F	E	D	C	B	...	4	3	2	1	0
Corresponding parameter	PF80	PF79	PF78	PF77	PF76	...	PF69	PF68	PF67	PF66	PF65

BOOT: Set if run home return or not at the first servo ON.

BOOT option	
Bit 28~31	Description
0	Do not run home return at the first servo ON.
1	Run home return at the first servo ON.

ORG_DEF: Defines the coordinate values of origin (not necessarily 0).

ORG_DEF data format
Pulse: $(-2^{31}) \sim (2^{31}-1)$

There is no function of origin stop mode in SDA drive which could set back to zero after home return.

Since after finding the origin (zero point signal or Z pulse), it must decelerate to stop and the position will be a short distance beyond the origin, as shown below:

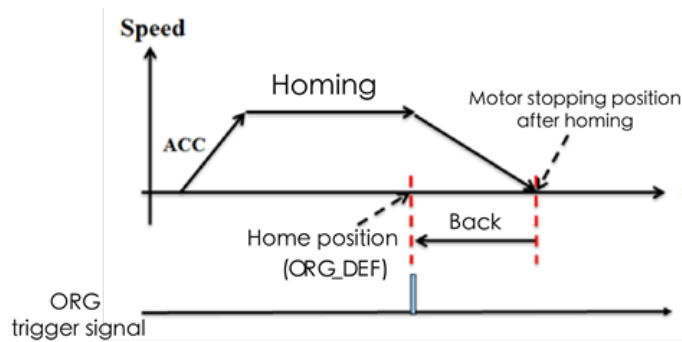

If PATH=0, the position will not move to origin point.

If PATH=A, the position will move to origin point and run PR#A automatically. Please set PR#A as absolute command of positioning control and let command =ORG_DEF.

There is no definition of offset about home return, where rather using the PATH to be specified as an offset value of a path.

It is recommended to use absolute position command and let command value = offset (absolute value).

7.5 The status of procedure connection

There are 63 groups procedure of PR mode could be set to five control types as constant speed, position, path jumping, parameters writing-in and index positioning. The 63 sets procedures consist of various different combination of control mode, PR mode of SDH provides three procedure connection functions such as AUTO (perform next procedure automatically), and insert to interrupt (INS) and overlapping (OVLP).AUTO and INS could be set at five-control mode, but OVLP just could be performed at positioning control, which continues positioning control mode.

Here are descriptions to three different connections:

(a) Sequence command:

If INS and OVLP are not set at PR mode, the procedure flow would be in original sequence. But if AUTO has been set at the previous procedure, the procedures will continuous to perform after previous procedure completed including the setting delay time.

(b) Overlapping command:

In the OVLP just could be performed at positioning control which continue positioning control mode. OVLP could be set at both two procedures are in position control mode to smooth the connection of procedure and reduce vibrations.

(c) Insert command:

Insert command means command is interrupted before completed in case of the command is replaced or combined by another command.

The final results will vary depending on the control type.

Sequence commands: Using the AUTO function to create a fixed procedure command combination.

PR#12 (AUTO position control · Incremental position stroke: 104857600 pulse · delay time: 200 ms) → PR#13 (position control · Absolute position: 0 pulse)

As shown as the following chart that it is a typical sequence command for the situation of positioning control continuous positioning control. The delay time is calculated after position completed.

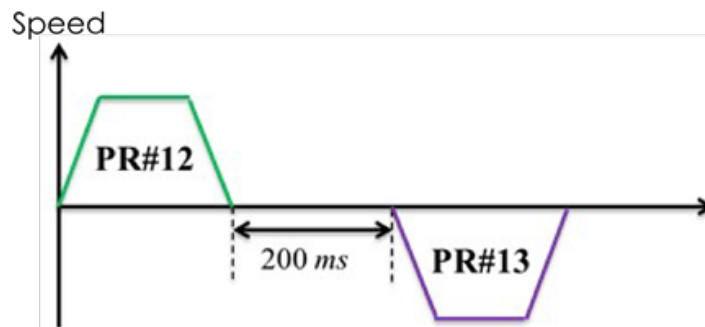

PR#12(AUTO speed control \ target speed:2000 rpm \ delay time: 200 ms) → PR#13 (position control \ absolute position : 0 pulse)

As shown as the following chart that it is a typical sequence command for the situation of constant speed control continuous positioning control. The delay time is calculated after position completed.

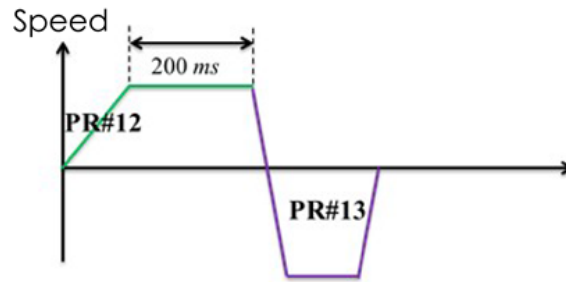

Overlapping command:

The latest position can choose whether to allow position control commands overlap at the situation of positioning control continuous positioning control in sequence command.

And the meaning of overlapping is the deceleration area of latest position command overlaps acceleration area of the next position command to let connection be smooth.

PR#12(AUTO position control \ overlapping \ incremental position stroke: 104857600 pulse \ target speed: 500 rpm \ delay time: 0 ms \ ACC: 400 ms) → PR#13(position control \ incremental position stroke: 104857600 pulse \ target speed: 700 rpm \ delay time: 0 ms \ DEC: 200 ms).

As shown as the following chart that two steps of position command could connect smoothly and reduce vibrations when switch to the next procedure.

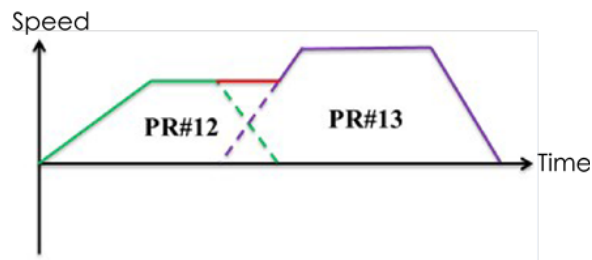

Insert command:

Insert command can be set to interrupt command or not at any control type and the insert command needs to be set at next procedure. There are two types in PR mode of SDH which are internal insert and external insert.

Internal insert:

The insert command is set at the next procedure in sequence command and the biggest difference with sequence command is the definition of delay time.

The delay time of sequence command is counted from reaching the target position or target speed, if internal insert is set, the delay time is counted form the origin of the previous procedure. The example is shown below:

PR#12(AUTO position control \ incremental position stroke: 10485760 pulse \ target speed: 600 rpm \ delay time: 1500 ms \ ACC: 200 ms \ DEC: 200 ms) → PR#13(position control \ Insert \ incremental position stroke: -10485760 pulse \ target speed: 600 rpm \ delay time: 0 ms \ ACC: 200 ms \ DEC: 200 ms).

Insert command can help time management of control procedure easily which shown as below.

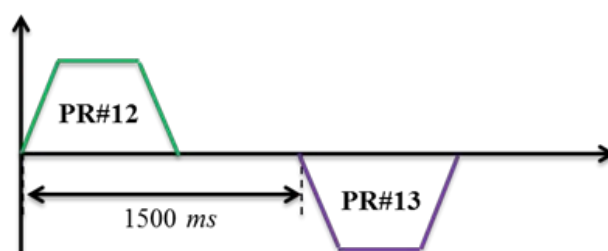

Internal insert should be noted that the delay time cannot be less than the period of time the procedure completed; otherwise it will appear that the previous procedure is not completed and interrupted by the next procedure, as shown in the following chart.

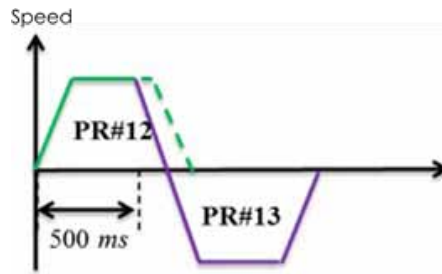

External INS: The difference of internal and external insert is that the internal insert could be triggered insert procedure by command and the external insert could be triggered by external signal. In addition, when an external insert occurs the setting delay time of the preceding procedures is invalid. Example shown as the following:

PR#12(AUTO position control \ incremental position stroke:10485760 pulse \ target speed: 600 rpm \ delay time: 1500 ms \ ACC: 200 ms \ DEC: 200 ms) → PR#13(position control \ Insert \ incremental position stroke:-10485760 pulse \ target speed: 600 rpm \ delay time: 0 ms \ ACC: 200 ms \ DEC: 200 ms).

The statement above is the pre-set control procedure flow, but when PR#07 position control \ insert \ absolute position coordination : 0 pulse \ target speed: 3000 rpm \ delay time: 0 ms \ ACC: 200 ms \ DEC: 200 ms) is triggered by external DI at 400ms, the result of procedure is as the chart below.

When the external insert occurs, the original sequence commands will be deleted immediately by external insert procedure. The external insert can be used as an emergency disposal.

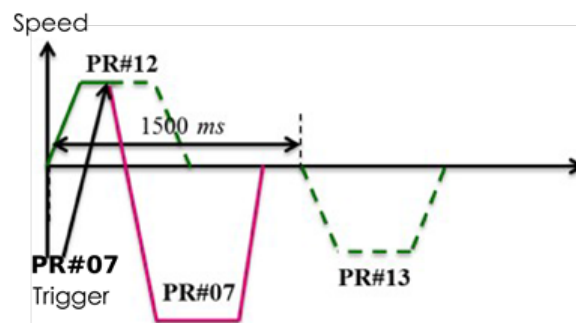

+
If there is an external trigger of new procedure, but this procedure is set no insert, the triggered procedure will be performed after the completion of the procedure being executed, as shown below.

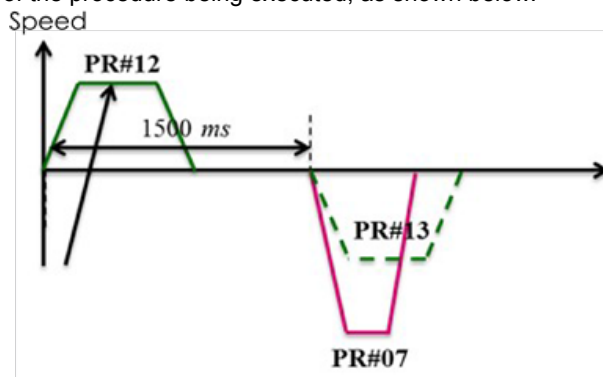

8. Parameters

8.1 Parameter definition

SDH servo drive's parameters are classified into the basic, gain values, filters, expansion and I/O group according to safety aspects and frequencies of use. When an advance adjustment is required, change the PA42 setting to make the expansion parameters write-enabled.

Here are some notes for reading of parameter manual.

(1) Parameter classification

Section 8.2 is a parameter list which is classified due to the functions for user to consult conveniently. Furthermore please read section 8.3 to know every parameter's details.

(2) Special symbol of parameter

- denotes the parameter change is vanished if once power off.
- (*) denotes the change is valid by power off once and power on again. The PA01 is an example.
- ▲ denotes the invalid change when the SON activated. The PA07 is another example.

There are 2 ways to make SON disable

- (a) Turn off the SON input.
- (b) Set the PD16 as 1 and the drive would be at Servo OFF state. But remember to recover it after the completion of modification

Group classification according to different functions is listed below.

Group	Description
Basic parameter (No PA□□)	When the position control is applied, please set this parameter group.
Gain, filter (No PB□□)	Used to perform the manual-gain tuning. Please set this parameter group.
Expansion (No PC□□)	Once the speed or torque control is required, please set this parameter group.
I/O settings (No PD□□)	Used to change the states of I/O signal. Please set this parameter group.
Pr route group 1 (No PE□□)	Used to program the route of inner position control, group 1.
Pr route group 2 (No PF□□)	Used to program the route of inner position control, group 2.

The control mode is described as follows

Mode		Sign	Description
Single mode	Position control (terminal input)	Pt	Drive runs motor to reach the goal according to the external pulse commands.
	Position control (inner register)	Pr	Drive runs motor to reach the goal according to the inner commands.
	Speed control	S	Drive runs motor to attain the target speed. The command type which is an analog voltage or the inner registers could be switched by DI.
	Torque control	T	The drive receives the commands to run the motor to generate the demanded torque. The command source is the analog voltage.
Hybrid mode		Pt-S	Pt/S is switched mutually via the LOP signal of DI.
		Pt-T	Pt/T is switched mutually via the LOP signal of DI
		Pr-S	Pr/S is switched mutually via the LOP signal of DI
		Pr-T	Pr/T is switched mutually via the LOP signal of DI.
		S-T	S/T is switched mutually via the LOP signal of DI.

8.2 Parameter list

The parameters of Shihlin servo drive could be classify into 5 groups. PA group is basic for control mode option, auto-tuning, etc. PB group is for gain and filter functions which enables to tune servo motor in stable operation. PC group is expansion parameter which is related to speed/torque control and analog signal and communication functions. PD group is for I/O parameters which enables users to set parameters for DI and DO. The following table is helpful for users to consult.

(1)Basic parameter

NO	Abbr.	Name	Initial Value	Unit	Control Mode			
					Pt	Pr	S	T
PA01(★)	STY	Control mode option	1000h	-	○	○	○	○
PA02(▲)	ATUM	Gain tuning mode option	0002h	-	○	○	○	
PA03	ATUL	Auto-tuning response level setting	10	-	○	○	○	
PA04	HMOV	Home moving option	0000h	-		○		
PA05	TL1	Inner torque limit 1	100	%	○	○	○	○
PA06	CMX	Electronic gear numerator	1	-	○	○		
PA07(▲)	CDV	Electronic gear denominator	1	-	○	○		
PA08	HSPD1	Home moving high speed option 1	1000	rpm		○		
PA09	HSPD2	Home moving high speed option 2	50	rpm		○		
PA10	RES1	Regenerative resistor value	-	Ohm	○	○	○	○
PA11	RES2	Regenerative resistor capacity		Watt	○	○	○	○
PA12	INP	In-position range	100	Pulse	○	○		
PA13(★)	PLSS	Command pulse option	0000h	-	○			
PA14(★)	ENR	Encoder output pulses	10000	pulse/rev	○	○	○	○
PA15	CRSHA	Motor crash protection level (percentage)	0	%	○	○	○	○
PA16	CRSHT	Motor crash protection (time)	1	ms	○	○	○	○
PA17	OVL	Output overload warning level	120	%	○	○	○	○
PA18	OVS	Overspeed warning	5500	rpm	○	○	○	○
PA19	OVPE	Position error excess	3x 2 ²²	pulse	○	○		
PA20(★)	OVPL1	Position pulse frequency excess level 1	530	KHz	○			
PA21(★)	OVPL2	Position pulse frequency excess level 2	4500	KHz	○			
PA22(★)	DBF	Dynamic brake control	0	-	○	○	○	○
PA23(■)	MCS	Memory write-inhibit function	0	-	○	○	○	○
PA24(★)	PRES	Linear scale resolution of full-closed loop	5000	pulse/rev	○	○		
PA25	PERR	Error protection range of full-closed loop	30000	pulse	○	○		
PA26(▲)	FCON	Full-closed loop control option	0000h	-	○	○		
PA27	FELP	Low-pass filter of full-closed loop	100	ms	○	○		
PA28(★)	ABS	Absolute encoder settings	0000h	-	○	○	○	○
PA29(■)	CAP	Absolute homing position	0000h	-	○	○	○	○
PA30(■)	UAP	Update encoder absolute position	0	-	○	○	○	○
PA31	APST	Absolute coordinate system state	0000h	-	○	○	○	○
PA32	APR	Encoder absolute position (pulse)	0	pulse	○	○	○	○
PA33	APP	Encoder absolute position (rev)	0	rev	○	○	○	○
PA34(★)	ABSM	I/O communication of absolute system	0	-	○	○	○	○
PA35~PA38	Reserved							
PA39(★)	POL	Motor rotary direction option	0000h	-	○	○	○	○
PA40(▲)	SPW	Special parameter write-enable	0000h	-	○	○	○	○
PA41	POSPD	Max. speed output setting of encoder	5500	rpm	○	○	○	○
PA42(★)	BLK	Parameter write-inhibit	0000h	-	○	○	○	○
PA43(★)	ENB	Encoder type option	0001h	-	○	○	○	○
PA44(★)	EGM	Electronic gear ratio mode	0	-	○	○		
PA45(★)	FBP	Position command pulse per revolution	10000	pulse	○	○		
PA46~PA50	Reserved							

(2) Gain, filter parameters

NO	Abbr.	Name	Initial Value	Unit	Control Mode			
					Pt	Pr	S	T
PB01	NHF1	Machine resonance suppression filter 1	1000	Hz	<input type="radio"/>	<input type="radio"/>	<input type="radio"/>	<input type="radio"/>
PB02	NHD1	Machine resonance suppression attenuation 1	0	dB	<input type="radio"/>	<input type="radio"/>	<input type="radio"/>	<input type="radio"/>
PB03	NLP	Resonance suppression low-pass filter	0	0.1ms	<input type="radio"/>	<input type="radio"/>	<input type="radio"/>	<input type="radio"/>
PB04	PST	Position command filter time constant	3	ms	<input type="radio"/>	<input type="radio"/>		
PB05	FFC	Position feed-forward gain	0	%	<input type="radio"/>	<input type="radio"/>		
PB06	GD1	The ratio of load inertia to motor shaft	10	0.1time	<input type="radio"/>	<input type="radio"/>	<input type="radio"/>	
PB07	PG1	Position loop gain	35	rad/s	<input type="radio"/>	<input type="radio"/>		
PB08	VG1	Speed loop gain	817	rad/s	<input type="radio"/>	<input type="radio"/>	<input type="radio"/>	
PB09	VIC	Speed integral gain	48	ms	<input type="radio"/>	<input type="radio"/>	<input type="radio"/>	
PB10	VFG	Speed feed-forward gain	0	0.0001			<input type="radio"/>	
PB11(★)	CDP	Gain switch condition	0000h	-	<input type="radio"/>	<input type="radio"/>	<input type="radio"/>	
PB12	CDS	Gain switch condition value	10	depends	<input type="radio"/>	<input type="radio"/>	<input type="radio"/>	
PB13	CDT	Gain switch time constant	1	ms	<input type="radio"/>	<input type="radio"/>	<input type="radio"/>	
PB14	GD2	The ratio 2 of load inertia to motor shaft	70	0.1time	<input type="radio"/>	<input type="radio"/>	<input type="radio"/>	
PB15	PG2	Position loop gain change ratio	100	%	<input type="radio"/>	<input type="radio"/>		
PB16	VG2	Speed loop gain change ratio	100	%	<input type="radio"/>	<input type="radio"/>	<input type="radio"/>	
PB17	VIC2	Speed integral gain change ratio	100	%	<input type="radio"/>	<input type="radio"/>	<input type="radio"/>	
PB18	SFLT	Speed low-pass filter smooth time constant	0	ms			<input type="radio"/>	<input type="radio"/>
PB19	TQC	Torque command filter time constant	0	ms				<input type="radio"/>
PB20	SJIT	Speed feedback filter time constant	0	0.1ms	<input type="radio"/>	<input type="radio"/>	<input type="radio"/>	<input type="radio"/>
PB21	NHF2	Machine resonance suppression filter 2	1000	Hz	<input type="radio"/>	<input type="radio"/>	<input type="radio"/>	<input type="radio"/>
PB22	NHD2	Machine resonance suppression attenuation 2	0	dB	<input type="radio"/>	<input type="radio"/>	<input type="radio"/>	<input type="radio"/>
PB23	Reserved							
PB24	VDC	Speed differential compensation	980	-	<input type="radio"/>	<input type="radio"/>	<input type="radio"/>	<input type="radio"/>
PB25	NHF3	Machine resonance suppression filter 3	1000	Hz	<input type="radio"/>	<input type="radio"/>	<input type="radio"/>	<input type="radio"/>
PB26	NHD3	Machine resonance suppression attenuation 3	0	dB	<input type="radio"/>	<input type="radio"/>	<input type="radio"/>	<input type="radio"/>
PB27	ANCF	Auto resonance suppression mode	1	-	<input type="radio"/>	<input type="radio"/>	<input type="radio"/>	<input type="radio"/>
PB28	ANCL	Resonance suppression detection level	50	%	<input type="radio"/>	<input type="radio"/>	<input type="radio"/>	<input type="radio"/>
PB29	AVSM	Auto vibration suppression mode	0	-	<input type="radio"/>	<input type="radio"/>		
PB30	VCL	Low-frequency vibration detection level	50	pulse	<input type="radio"/>	<input type="radio"/>		
PB31	VSF1	Vibration suppression frequency 1	100	0.1Hz	<input type="radio"/>	<input type="radio"/>		
PB32	VSG1	Vibration suppression gain 1	0	-	<input type="radio"/>	<input type="radio"/>		
PB33	VSF2	Vibration suppression frequency 2	100	0.1Hz	<input type="radio"/>	<input type="radio"/>		
PB34	VSG2	Vibration suppression gain 2	0	-	<input type="radio"/>	<input type="radio"/>		
PB35	FRCL	Friction compensation level	0	%	<input type="radio"/>	<input type="radio"/>	<input type="radio"/>	
PB36	FRCT	Friction compensation filter time constant	0	ms	<input type="radio"/>	<input type="radio"/>	<input type="radio"/>	
PB37	FRCM	Friction compensation option	0	-	<input type="radio"/>	<input type="radio"/>	<input type="radio"/>	
PB38	FFCT	Position feed forward filter time constant	0	ms	<input type="radio"/>	<input type="radio"/>		
PB39(▲)	SVP	Synchronous motion speed gain	0	rad/s	<input type="radio"/>	<input type="radio"/>	<input type="radio"/>	<input type="radio"/>
PB40(▲)	SVI	Synchronous motion speed integral constant	0	rad/s	<input type="radio"/>	<input type="radio"/>	<input type="radio"/>	<input type="radio"/>
PB41(▲)	SPI	Synchronous motion position integral constant	0	rad	<input type="radio"/>	<input type="radio"/>	<input type="radio"/>	<input type="radio"/>
PB42(▲)	SBW	Synchronous motion control bandwidth	0	Hz	<input type="radio"/>	<input type="radio"/>	<input type="radio"/>	<input type="radio"/>
PB43	SVL	Synchronous motion speed error filter constant	0	0.1ms	<input type="radio"/>	<input type="radio"/>	<input type="radio"/>	<input type="radio"/>
PB44~PB50	Reserved							

(3) Expansion parameters

NO	Abbr.	Name	Initial Value	Unit	Control Mode			
					Pt	Pr	S	T
PC01	STA	Acceleration time constant	200	ms		○	○	○
PC02	STB	Deceleration time constant	200	ms		○	○	○
PC03	STC	S-pattern acc./dec. time constant	0	ms		○	○	○
PC04	JOG	JOG speed command	300	rpm	○	○	○	○
PC05	SC1	Inner speed command/limit 1	100	rpm			○	○
PC06	SC2	Inner speed command/limit 2	500	rpm			○	○
PC07	SC3	Inner speed command/limit 3	1000	rpm			○	○
PC08	SC4	Inner speed command/limit 4	200	rpm			○	○
PC09	SC5	Inner speed command/limit 5	300	rpm			○	○
PC10	SC6	Inner speed command/limit 6	500	rpm			○	○
PC11	SC7	Inner speed command/limit 7	800	rpm			○	○
PC12(▲)	VCM	Output speed of maximum analog command	3000	rpm			○	○
PC13(▲)	TLC	Torque generated of maximum analog command	100	%	○	○	○	○
PC14	MOD	Analog monitor output	0100h	-	○	○	○	○
PC15(★)	SVZR	Speed analog zero voltage acknowledged range	10	mV			○	○
PC16	MBR	Electromagnetic brake output delay time	100	ms	○	○	○	○
PC17	ZSP	Zero speed acknowledged range	50	rpm	○	○	○	○
PC18(★)	COP1	Stop option and power interruption restart option	0010h	-	○	○	○	○
PC19(★)	COP2	Alarm history clear option and overload pre-warn option	0000h	-	○	○	○	○
PC20(★)	SNO	Communication device number	1	-	○	○	○	○
PC21(★)	CMS	Communication mode option	0010h	-	○	○	○	○
PC22(★)	BPS	Communication protocol option	0010h	-	○	○	○	○
PC23	SIC	Communication time-out process option	0	s	○	○	○	○
PC24(★)	DMD	Status display option	0000h	-	○	○	○	○
PC25	TL2	Inner torque limit 2	100	%	○	○	○	○
PC26	VCO	Speed analog command/limit offset	0	mV			○	○
PC27	TLO	Torque analog command/limit offset	0	mV			○	○
PC28	MO1	Analog monitor ch1 offset	0	mV	○	○	○	○
PC29	MO2	Analog monitor ch2 offset	0	mV	○	○	○	○
PC30	MOG1	Analog monitor ch1 output proportion	100	%	○	○	○	○
PC31	MOG2	Analog monitor ch2 output proportion	100	%	○	○	○	○
PC32	CMX2	Electronic gear numerator 2	1	-	○	○		
PC33	CMX3	Electronic gear numerator 3	1	-	○	○		
PC34	CMX4	Electronic gear numerator 4	1	-	○	○		
PC35(★)	VCL	VC voltage limit	0	mV			○	○
PC36 ~ PC60	Reserved							

(4) I/O setting parameters

NO	Abbr.	Name	Initial Value	Unit	Control Mode			
					Pt	Pr	S	T
PD01(★)	DIA1	Digital input signal auto-ON option 1	0000h	-	○	○	○	○
PD02(★)	DI1	Digital input 1 option	0001h	-	○	○	○	○
PD03(★)	DI2	Digital input 2 option	0007h	-	○	○	○	○
PD04(★)	DI3	Digital input 3 option	0009h	-	○	○	○	○
PD05(★)	DI4	Digital input 4 option	000Ah	-	○	○	○	○
PD06(★)	DI5	Digital input 5 option	0002h	-	○	○	○	○
PD07(★)	DI6	Digital input 6 option	0006h	-	○	○	○	○
PD08(★)	DI7	Digital input 7 option	0012h	-	○	○	○	○
PD09(★)	DI8	Digital input 8 option	0011h	-	○	○	○	○
PD10(★)	DO1	Digital output 1 option	0003h	-	○	○	○	○
PD11(★)	DO2	Digital output 2 option	0008h	-	○	○	○	○
PD12(★)	DO3	Digital output 3 option	0007h	-	○	○	○	○
PD13(★)	DO4	Digital output 4 option	0005h	-	○	○	○	○
PD14(★)	DO5	Digital output 5 option	0001h	-	○	○	○	○
PD15(★)	DIF	Digital input filter time option	0002h	-	○	○	○	○
PD16(■)	SDI	Digital input on/off state control option	0000h	-	○	○	○	○
PD17(★)	DOP1	LSP/LSN triggered stop option	0000h	-	○	○	○	
PD18(★)	DOP2	CR signal clear option	0000h	-	○	○		
PD19(★)	DOP3	Alarm code output option	0000h	-	○	○	○	○
PD20(★)	DOP4	Alarm reset triggered process	0000h	-	○	○	○	○
PD21(★)	DI9	Digital input 9 option	0018h	-	○	○	○	○
PD22(★)	DI10	Digital input 10 option	0019h	-	○	○	○	○
PD23(★)	DI11	Digital input 11 option	0005h	-	○	○	○	○
PD24(★)	DI12	Digital input 12 option	0010h	-	○	○	○	○
PD25(■)	ITST	Communication control DI on/off state	0000h	-	○	○	○	○
PD26(★)	DO6	Digital output 6 option	0002h	-	○	○	○	○
PD27(★)	DOD	Digital output logic option	0020h	-	○	○	○	○
PD28	MCOK	Move arrive (DO:MC_OK) operation option	0000h	-		○		
PD29~PD40	Reserved							

(5) Pr position path planning parameter group 1

NO	Abbr.	Name	Initial Value	Unit	Control Mode			
					Pt	Pr	S	T
PE01	ODEF	Origin return Definition	00000000h	-		○		
PE02	ODAT	Origin Data value	0	-		○		
PE03	PDEF1	PATH#1 Definition	00000000h	-		○		
PE04	PDAT1	PATH#1 Data	0	-		○		
PE05	PDEF2	PATH#2 Definition	00000000h	-		○		
PE06	PDAT2	PATH#2 Data	0	-		○		
PE07	PDEF3	PATH#3 Definition	00000000h	-		○		
PE08	PDAT3	PATH#3 Data	0	-		○		
PE09	PDEF4	PATH#4 Definition	00000000h	-		○		
PE10	PDAT4	PATH#4 Data	0	-		○		
PE11	PDEF5	PATH#5 Definition	00000000h	-		○		
PE12	PDAT5	PATH#5 Data	0	-		○		
PE13	PDEF6	PATH#6 Definition	00000000h	-		○		
PE14	PDAT6	PATH#6 Data	0	-		○		
PE15	PDEF7	PATH#7 Definition	00000000h	-		○		
PE16	PDAT7	PATH#7 Data	0	-		○		
PE17	PDEF8	PATH#8 Definition	00000000h	-		○		
PE18	PDAT8	PATH#8 Data	0	-		○		
PE19	PDEF9	PATH#9 Definition	00000000h	-		○		
PE20	PDAT9	PATH#9 Data	0	-		○		
PE21	PDEF10	PATH#10 Definition	00000000h	-		○		
PE22	PDAT10	PATH#10 Data	0	-		○		
PE23	PDEF11	PATH#11 Definition	00000000h	-		○		
PE24	PDAT11	PATH#11 Data	0	-		○		
PE25	PDEF12	PATH#12 Definition	00000000h	-		○		
PE26	PDAT12	PATH#12 Data	0	-		○		
PE27	PDEF13	PATH#13 Definition	00000000h	-		○		
PE28	PDAT13	PATH#13 Data	0	-		○		
PE29	PDEF14	PATH#14 Definition	00000000h	-		○		
PE30	PDAT14	PATH#14 Data	0	-		○		
PE31	PDEF15	PATH#15 Definition	00000000h	-		○		
PE32	PDAT15	PATH#15 Data	0	-		○		
PE33	PDEF16	PATH#16 Definition	00000000h	-		○		
PE34	PDAT16	PATH#16 Data	0	-		○		
PE35	PDEF17	PATH#17 Definition	00000000h	-		○		
PE36	PDAT17	PATH#17 Data	0	-		○		
PE37	PDEF18	PATH#18 Definition	00000000h	-		○		
PE38	PDAT18	PATH#18 Data	0	-		○		
PE39	PDEF19	PATH#19 Definition	00000000h	-		○		
PE40	PDAT19	PATH#19 Data	0	-		○		
PE41	PDEF20	PATH#20 Definition	00000000h	-		○		
PE42	PDAT20	PATH#20 Data	0	-		○		
PE43	PDEF21	PATH#21 Definition	00000000h	-		○		
PE44	PDAT21	PATH#21 Data	0	-		○		
PE45	PDEF22	PATH#22 Definition	00000000h	-		○		
PE46	PDAT22	PATH#22 Data	0	-		○		
PE47	PDEF23	PATH#23 Definition	00000000h	-		○		
PE48	PDAT23	PATH#23 Data	0	-		○		
PE49	PDEF24	PATH#24 Definition	00000000h	-		○		
PE50	PDAT24	PATH#24 Data	0	-		○		
PE51	PDEF25	PATH#25 Definition	00000000h	-		○		
PE52	PDAT25	PATH#25 Data	0	-		○		
PE53	PDEF26	PATH#26 Definition	00000000h	-		○		
PE54	PDAT26	PATH#26 Data	0	-		○		
PE55	PDEF27	PATH#27 Definition	00000000h	-		○		
PE56	PDAT27	PATH#27 Data	0	-		○		
PE57	PDEF28	PATH#28 Definition	00000000h	-		○		

PE58	PDAT28	PATH#28 Data	0	-	o		
PE59	PDEF29	PATH#29 Definition	00000000h	-	o		
PE60	PDAT29	PATH#29 Data	0	-	o		
PE61	PDEF30	PATH#30 Definition	00000000h	-	o		
PE62	PDAT30	PATH#30 Data	0	-	o		
PE63	PDEF31	PATH#31 Definition	00000000h	-	o		
PE64	PDAT31	PATH#31 Data	0	-	o		
PE65	PDEF32	PATH#32 Definition	00000000h	-	o		
PE66	PDAT32	PATH#32 Data	0	-	o		
PE67	PDEF33	PATH#33 Definition	00000000h	-	o		
PE68	PDAT33	PATH#33 Data	0	-	o		
PE69	PDEF34	PATH#34 Definition	00000000h	-	o		
PE70	PDAT34	PATH#34 Data	0	-	o		
PE71	PDEF35	PATH#35 Definition	00000000h	-	o		
PE72	PDAT35	PATH#35 Data	0	-	o		
PE73	PDEF36	PATH#36 Definition	00000000h	-	o		
PE74	PDAT36	PATH#36 Data	0	-	o		
PE75	PDEF37	PATH#37 Definition	00000000h	-	o		
PE76	PDAT37	PATH#37 Data	0	-	o		
PE77	PDEF38	PATH#38 Definition	00000000h	-	o		
PE78	PDAT38	PATH#38 Data	0	-	o		
PE79	PDEF39	PATH#39 Definition	00000000h	-	o		
PE80	PDAT39	PATH#39 Data	0	-	o		
PE81	PDEF40	PATH#40 Definition	00000000h	-	o		
PE82	PDAT40	PATH#40 Data	0	-	o		
PE83	PDEF41	PATH#41 Definition	00000000h	-	o		
PE84	PDAT41	PATH#41 Data	0	-	o		
PE85	PDEF42	PATH#42 Definition	00000000h	-	o		
PE86	PDAT42	PATH#42 Data	0	-	o		
PE87	PDEF43	PATH#43 Definition	00000000h	-	o		
PE88	PDAT43	PATH#43 Data	0	-	o		
PE89	PDEF44	PATH#44 Definition	00000000h	-	o		
PE90	PDAT44	PATH#44 Data	0	-	o		
PE91	PDEF45	PATH#45 Definition	00000000h	-	o		
PE92	PDAT45	PATH#45 Data	0	-	o		
PE93	PDEF46	PATH#46 Definition	00000000h	-	o		
PE94	PDAT46	PATH#46 Data	0	-	o		
PE95	PDEF47	PATH#47 Definition	00000000h	-	o		
PE96	PDAT47	PATH#47 Data	0	-	o		
PE97	PDEF48	PATH#48 Definition	00000000h	-	o		
PE98	PDAT48	PATH#48 Data	0	-	o		
PE99		Reserved					

(6)Pr position path planning parameter group 2

NO	Abbr.	Name	Initial Value	Unit	Control Mode			
					Pt	Pr	S	T
PF01	PDEF49	PATH#49 Definition	00000000h	-		○		
PF02	PDAT49	PATH#49 Data	0	-		○		
PF03	PDEF50	PATH#50 Definition	00000000h	-		○		
PF04	PDAT50	PATH#50 Data	0	-		○		
PF05	PDEF51	PATH#51 Definition	00000000h	-		○		
PF06	PDAT51	PATH#51 Data	0	-		○		
PF07	PDEF52	PATH#52 Definition	00000000h	-		○		
PF08	PDAT52	PATH#52 Data	0	-		○		
PF09	PDEF53	PATH#53 Definition	00000000h	-		○		
PF10	PDAT53	PATH#53 Data	0	-		○		
PF11	PDEF54	PATH#54 Definition	00000000h	-		○		
PF12	PDAT54	PATH#54 Data	0	-		○		
PF13	PDEF55	PATH#55 Definition	00000000h	-		○		
PF14	PDAT55	PATH#55 Data	0	-		○		
PF15	PDEF56	PATH#56 Definition	00000000h	-		○		
PF16	PDAT56	PATH#56 Data	0	-		○		
PF17	PDEF57	PATH#57 Definition	00000000h	-		○		
PF18	PDAT57	PATH#57 Data	0	-		○		
PE19	PDEF58	PATH#58 Definition	00000000h	-		○		
PF20	PDAT58	PATH#58 Data	0	-		○		
PF21	PDEF59	PATH#59 Definition	00000000h	-		○		
PF22	PDAT59	PATH#59 Data	0	-		○		
PF23	PDEF60	PATH#60 Definition	00000000h	-		○		
PF24	PDAT60	PATH#60 Data	0	-		○		
PF25	PDEF61	PATH#61 Definition	00000000h	-		○		
PF26	PDAT61	PATH#61 Data	0	-		○		
PF27	PDEF62	PATH#62 Definition	00000000h	-		○		
PF28	PDAT62	PATH#62 Data	0	-		○		
PF29	PDEF63	PATH#63 Definition	00000000h	-		○		
PF30	PDAT63	PATH#63 Data	0	-		○		
PF31	Reserved							
PF32	Reserved							
PF33	POV1	Speed setting of Internal position command 1	50	rpm		○		
PF34	POV2	Speed setting of Internal position command 2	10	rpm		○		
PF35	POV3	Speed setting of Internal position command 3	200	rpm		○		
PF36	POV4	Speed setting of Internal position command 4	300	rpm		○		
PF37	POV5	Speed setting of Internal position command 5	500	rpm		○		
PF38	POV6	Speed setting of Internal position command 6	800	rpm		○		
PF39	POV7	Speed setting of Internal position command 7	1000	rpm		○		
PF40	POV8	Speed setting of Internal position command 8	1200	rpm		○		
PF41	POV9	Speed setting of Internal position command 9	1500	rpm		○		
PF42	POV10	Speed setting of Internal position command 10	1800	rpm		○		
PF43	POV11	Speed setting of Internal position command 11	2000	rpm		○		
PF44	POV12	Speed setting of Internal position command 12	2200	rpm		○		
PF45	POV13	Speed setting of Internal position command 13	2400	rpm		○		
PF46	POV14	Speed setting of Internal position command 14	2700	rpm		○		
PF47	POV15	Speed setting of Internal position command 15	3000	rpm		○		
PF48	POV16	Speed setting of Internal position command 16	3000	rpm		○		
PF49	POA1	Acceleration and deceleration time of internal position command 1	200	ms		○		
PF50	POA2	Acceleration and deceleration time of internal position command 2	300	ms		○		
PF51	POA3	Acceleration and deceleration time of internal position command 3	500	ms		○		
PF52	POA4	Acceleration and deceleration time of internal position command 4	600	ms		○		
PF53	POA5	Acceleration and deceleration time of internal position command 5	800	ms		○		

PF54	POA6	Acceleration and deceleration time of internal position command 6	900	ms		○		
PF55	POA7	Acceleration and deceleration time of internal position command 7	1000	ms		○		
PF56	POA8	Acceleration and deceleration time of internal position command 8	1200	ms		○		
PF57	POA9	Acceleration and deceleration time of internal position command 9	1400	ms		○		
PF58	POA10	Acceleration and deceleration time of internal position command 10	1600	ms		○		
PF59	POA11	Acceleration and deceleration time of internal position command 11	2000	ms		○		
PF60	POA12	Acceleration and deceleration time of internal position command 12	2500	ms		○		
PF61	POA13	Acceleration and deceleration time of internal position command 13	3000	ms		○		
PF62	POA14	Acceleration and deceleration time of internal position command 14	4000	ms		○		
PF63	POA15	Acceleration and deceleration time of internal position command 15	5000	ms		○		
PF64	POA16	Acceleration and deceleration time of internal position command 16	6000	ms		○		
PF65	DLY1	Delay time after position reached 1	0	ms		○		
PF66	DLY2	Delay time after position reached 2	100	ms		○		
PF67	DLY3	Delay time after position reached 3	200	ms		○		
PF68	DLY4	Delay time after position reached 4	300	ms		○		
PF69	DLY5	Delay time after position reached 5	500	ms		○		
PF70	DLY6	Delay time after position reached 6	600	ms		○		
PF71	DLY7	Delay time after position reached 7	800	ms		○		
PF72	DLY8	Delay time after position reached 8	1000	ms		○		
PF73	DLY9	Delay time after position reached 9	1200	ms		○		
PF74	DLY10	Delay time after position reached 10	1500	ms		○		
PF75	DLY11	Delay time after position reached 11	2000	ms		○		
PF76	DLY12	Delay time after position reached 12	2300	ms		○		
PF77	DLY13	Delay time after position reached 13	2500	ms		○		
PF78	DLY14	Delay time after position reached 14	3000	ms		○		
PF79	DLY15	Delay time after position reached 15	4000	ms		○		
PF80	DLY16	Delay time after position reached 16	5000	ms		○		
PF81	PDEC	Auto-protection of deceleration time	00000000h	ms	○	○	○	○
PF82(■)	PRCM	PR command trigger registers	0	-		○		
PF83	EVON	Event on trigger PR program No.	0000h	-		○		
PF84	EVOF	Event off trigger PR program No.	0000h	-		○		
PF85(■)	PMEM	Don't memory data setting when power off	0000h	-	○	○	○	○
PF86	SWLP	Software limit : positive	$2^{31}-1$	pulse		○		
PF87	SWLN	Software limit: negative	$-2^{31}+1$	pulse		○		
PF88~PF99								

The following table including the relevant parameters with different modes is helpful for users convenient to consult.

Torque control related parameters								
NO	Abbr.	Name	Initial Value	Unit	Control Mode			
					Pt	Pr	S	T
PA01(*)	STY	Control mode setting value	1000h	-	○	○	○	○
PA05	TL1	Internal torque limit 1	100	%	○	○	○	○
PC05	SC1	Internal speed limit 1	100	rpm			○	○
PC06	SC2	Internal speed limit 2	500	rpm			○	○
PC07	SC3	Internal speed limit 3	1000	rpm			○	○
PC08	SC4	Internal speed limit 4	200	rpm			○	○
PC09	SC5	Internal speed limit 5	300	rpm			○	○
PC10	SC6	Internal speed limit 6	500	rpm			○	○
PC11	SC7	Internal speed limit 7	800	rpm			○	○
PC12 (▲)	VCM	Analog speed limit maximum rotation speed	3000	rpm			○	○
PC13 (▲)	TLC	Analog torque command maximum output	100	%	○	○	○	○
PC25	TL2	Internal torque limit 2	100	%	○	○	○	○
PC26	VCO	Analog speed limit offset	0	mV			○	○
PC27	TLO	Analog torque command offset	0	mV			○	○
PC35(*)	VCL	VC Voltage limit	0	mV			○	○

Speed control related parameters								
NO	Abbr.	Name	Initial Value	Unit	Control Mode			
					Pt	Pr	S	T
PA01(*)	STY	Control mode setting value	1000h	-	○	○	○	○
PA05	TL1	Internal torque limit 1	100	%	○	○	○	○
PA14(*)	ENR	Encoder output pulses	10000	pulse/rev	○	○	○	○
PB18	SFLT	Speed command low-pass smoothing time constant	0	ms			○	○
PC05	SC1	Internal speed command 1	100	rpm			○	○
PC06	SC2	Internal speed command 2	500	rpm			○	○
PC07	SC3	Internal speed command 3	1000	rpm			○	○
PC08	SC4	Internal speed command 4	200	rpm			○	○
PC09	SC5	Internal speed command 5	300	rpm			○	○
PC10	SC6	Internal speed command 6	500	rpm			○	○
PC11	SC7	Internal speed command 7	800	rpm			○	○
PC12 (▲)	VCM	Analog speed command – Maximum rotation speed	3000	rpm			○	○
PC25	TL2	Internal torque limit 2	100	%	○	○	○	○
PC26	VCO	Analog speed command offset	0	mV			○	○
PC27	TLO	Analog torque limit offset	0	mV			○	○
PC35(*)	VCL	VC Voltage limit	0	mV			○	○

Position control related parameters								
NO	Abbr.	Name	Initial Value	Unit	Control Mode			
					Pt	Pr	S	T
PA01(*)	STY	Control mode setting value	1000h	-	○	○	○	○
PA04	HMOV	Home moving mode	0000h	-		○		
PA05	TL1	Inner torque limit 1	100	%	○	○	○	○
PA06	CMX	Electronic gear numerator	1	-	○	○		
PA07 (▲)	CDV	Electronic gear denominator	1	-	○	○		
PA13 (*)	PLSS	Command pulse option	0000h	-	○			
PA14 (*)	ENR	Encoder output pulses	10000	Pulse/rev	○	○	○	○
PA39(*)	POL	Motor rotary direction option	0000h	-	○	○	○	○
PC25	TL2	Inner torque limit 2	100	%	○	○	○	○
PC32	CMX2	Electronic gear numerator 2	1	-	○	○		
PC33	CMX3	Electronic gear numerator 3	1	-	○	○		
PC34	CMX4	Electronic gear numerator 4	1	-	○	○		
PE01	ODEF	Origin return Definition	00000000h	-		○		
PE02	ODAT	Origin Data value	0	-		○		
PE03~PE98		PR mode related definition. Details refer to section 8.3				○		
PF01~PF87		PR mode related definition. Details refer to section 8.3				○		

Smoothing filter and resonance suppression related parameters								
NO	Abbr.	Name	Initial Value	Unit	Control Mode			
					Pt	Pr	S	T
PB01	NHF1	Machine resonance suppression filter 1	1000	Hz	○	○	○	○
PB02	NHD1	Machine resonance suppression attenuation 1	0	dB	○	○	○	○
PB03	NLP	Resonance suppression low-pass filter	10	0.1ms	○	○	○	○
PB04	PST	Position command filter time constant	3	ms	○	○		
PB19	TQC	Torque command filter time constant	0	ms				○
PB20	SJIT	Speed feedback filter time constant	0	0.1ms	○	○	○	○
PB21	NHF2	Machine resonance suppression filter 2	1000	Hz	○	○	○	○
PB22	NHD2	Machine resonance suppression attenuation 2	0	dB	○	○	○	○
PB23	Reserved							
PB25	NHF3	Machine resonance suppression filter 3	1000	Hz	○	○	○	○
PB26	NHD3	Machine resonance suppression attenuation 3	0	dB	○	○	○	○
PB27	ANCF	Auto resonance suppression mode	1	-	○	○	○	○
PB28	ANCL	Resonance suppression detection level	50	%	○	○	○	○
PB29	AVSM	Auto vibration suppression mode	0	-	○	○		
PB30	VCL	Low-frequency vibration detection level	50	pulse	○	○		
PB31	VSF1	Vibration suppression frequency 1	100	0.1Hz	○	○		
PB32	VSG1	Vibration suppression gain 1	0	-	○	○		
PB33	VSF2	Vibration suppression frequency 2	100	0.1Hz	○	○		
PB34	VSG2	Vibration suppression gain 2	0	-	○	○		
PB35	FRCL	Friction compensation level	0	%	○	○	○	
PB36	FRCT	Friction compensation filter time constant	0	ms	○	○	○	
PB37	FRCM	Friction compensation option	0	-	○	○	○	
PB38	FFCT	Position feed forward filter time constant	0	ms	○	○		
PC01	STA	Acceleration time constant	200	ms		○	○	○
PC02	STB	Deceleration time constant	200	ms		○	○	○
PC03	STC	S-pattern acc./dec. time constant	0	ms		○	○	○
PD17(*)	DOP1	LSP/LSN triggered stop option	0000h	-	○	○	○	

Control gain and gain switch related parameters								
NO	Abbr.	Name	Initial Value	Unit	Control Mode			
					Pt	Pr	S	T
PA02	ATUM	Gain tuning mode option	0002h	-	○	○	○	○
PA03	ATUL	Auto-tuning response level setting	0010	-	○	○	○	○
PB05	FFC	Position feed-forward gain	0	0.0001	○	○		
PB07	PG1	Position loop gain	45	rad/s	○	○		
PB08	VG1	Speed loop gain	183	rad/s	○	○	○	
PB09	VIC	Speed integral gain	34	ms	○	○	○	
PB10	VFG	Speed feed-forward gain	0	0.0001			○	
PB11(*)	CDP	Gain switch condition	0000h	-	○	○	○	
PB12	CDS	Gain switch condition value	10	Kpps / Pulse / rpm	○	○	○	
PB13	CDT	Gain switch time constant	1	ms	○	○	○	
PB14	GD2	The ratio 2 of load inertia to motor shaft	70	0.1time	○	○	○	
PB15	PG2	Position loop gain change ratio	100	%	○	○		
PB16	VG2	Speed loop gain change ratio	100	%	○	○	○	
PB17	VIC2	Speed integral gain change ratio	100	%	○	○	○	
PB24	VDC	Speed differential compensation	980	-	○	○	○	

Digital I/O settings related parameters								
NO	Abbr.	Name	Initial Value	Unit	Control Mode			
					Pt	Pr	S	T
PA12	INP	In-position range	41943	pulse	○	○		
PC17	ZSP	Zero speed acknowledged range	50	rpm	○	○	○	○
PC16	MBR	Electromagnetic brake output delay time	100	ms	○	○	○	○
PD01(*)	DIA1	Digital input signal auto-ON option 1	0000h	-	○	○	○	○
PD02(*)	DI1	Digital input 1 option(CN1-14)	0001h	-	○	○	○	○
PD03(*)	DI2	Digital input 2 option(CN1-15)	000Dh	-	○	○	○	○

PD04(*)	DI3	Digital input 3 option(CN1-16)	0003h	-	o	o	o	o
PD05(*)	DI4	Digital input 4 option(CN1-17)	0004h	-	o	o	o	o
PD06(*)	DI5	Digital input 5 option(CN1-18)	0002h	-	o	o	o	o
PD07(*)	DI6	Digital input 6 option(CN1-19)	000Fh	-	o	o	o	o
PD08(*)	DI7	Digital input 7 option(CN1-20)	0012h	-	o	o	o	o
PD09(*)	DI8	Digital input 8 option(CN1-21)	0011h	-	o	o	o	o
PD10(*)	DO1	Digital output 1 option(CN1-41)	0003h	-	o	o	o	o
PD11(*)	DO2	Digital output 2 option(CN1-42)	0008h	-	o	o	o	o
PD12(*)	DO3	Digital output 3 option(CN1-43)	0007h	-	o	o	o	o
PD13(*)	DO4	Digital output 4 option(CN1-44)	0005h	-	o	o	o	o
PD14(*)	DO5	Digital output 5 option(CN1-45)	0001h	-	o	o	o	o
PD15(*)	DIF	Digital input filter time option	0002h	-	o	o	o	o
PD16(*)	IOS	Digital input on/off state control option	0000h	-	o	o		
PD17(*)	DOP1	LSP/LSN triggered stop option	0000h	-	o	o	o	
PD18(*)	DOP2	R signal clear option	0000h	-	o	o		
PD19(*)	DOP3	Alarm code output option	0000h	-	o	o	o	o
PD20(*)	DOP4	Alarm reset triggered process	0000h	-	o	o	o	o
PD21(*)	DI9	Digital input 9 option	0018h	-	o	o	o	o
PD22(*)	DI10	Digital input 10 option	0019h	-	o	o	o	o
PD23(*)	DI11	Digital input 11 option	0005h	-	o	o	o	o
PD24(*)	DI12	Digital input 12 option	0010h	-	o	o	o	o
PD25(■)	ITST	Communication control DI on/off state	0000h	-	o	o	o	o
PD26(*)	DO6	Digital output 6 option	0002h	-	o	o	o	o
PD27(*)	DOD	Digital output logic option	0020h	-	o	o	o	o

Communication related parameters								
NO	Abbr.	Name	Initial Value	Unit	Control Mode			
					Pt	Pr	S	T
PC20(*)	SNO	Communication device number	1	-	o	o	o	o
PC21(*)	CMS	Communication mode option	0010h	-	o	o	o	o
PC22(*)	BPS	Communication protocol option	0010h	-	o	o	o	o
PC23	SIC	Communication time-out process option	0	s	o	o	o	o

Monitor and status display related parameters								
NO	Abbr.	Name	Initial Value	Unit	Control Mode			
					Pt	Pr	S	T
PC14	MOD	Analog monitor output	0100h	-	o	o	o	o
PC24(*)	DMD	Status display option	0000h	-	o	o	o	o
PC28	MO1	Analog monitor ch1 offset	0	mV	o	o	o	o
PC29	MO2	Analog monitor ch2 offset	0	mV	o	o	o	o
PC30	MOG1	Analog monitor ch1 output proportion	100	%	o	o	o	o
PC31	MOG2	Analog monitor ch2 output proportion	100	%	o	o	o	o

Other functions related parameters								
NO	Abbr.	Name	Initial Value	Unit	Control Mode			
					Pt	Pr	S	T
PA40(▲)	SPW	Special parameter write-enable	0000h	-	o	o	o	o
PA42(*)	BLK	Parameter write-inhibit	0000h	-	o	o	o	o
PB06	GD1	The ratio of load inertia to motor shaft	70	0.1time	o	o	o	
PB14	GD2	The ratio 2 of load inertia to motor shaft	70	0.1time	o	o	o	
PC18(*)	COP1	Stop option and power interruption restart option	0010h	-	o	o	o	o
PC19(*)	COP2	Alarm history clear option	0000h	-	o	o	o	o
PD20(*)	DOP4	Alarm reset triggered process	0000h	-	o	o	o	o

8.3 Parameter details list

No	Abbr.	Function description	Control Mode	Initial Value	Setting range	unit																																																																												
PA01	STY (*)	Setting value of Control mode option: <div style="border: 1px solid black; display: inline-block; padding: 2px;">u z y x</div> x:control mode select 0:position 1:position/speed 2:speed 3:speed/torque 4:torque 5:torque/position y:position command select 0: external input 1:inner register(absolute type) 2:inner register(incremental type) z:electromagnetic brake enabled option 0:disabled 1:enabled. (Motor with electromagnetic brake applied) u:DI/DO setting option 0:Functions of DI/DO are fixed as user defined no matter what control mode switched. 1:Functions of DI/DO are changed as control mode switched. Pin functions are decided by servo drive automatically.	Pr.Pt S.T	1000h	0000h ~ 1115h	-																																																																												
PA02	ATUM (▲)	Gain tuning mode option: x:gain tuning mode option 0>manual-gain tuning(PI control) 1: manual-gain tuning(PI control + interference compensator) 2: Auto-gain tuning(load inertia ratio and bandwidth estimated) 3: Auto-gain tuning(fixed load inertia ratio) 4:Interpolation mode(PB37 is fixed, other gain value estimated)	Pr. Pt. S. T	0002h	0000h ~ 0003h	-																																																																												
PA03	ATUL	Auto-tuning response level setting: <div style="border: 1px solid black; display: inline-block; padding: 2px;">0 0 0 x</div> x: response level setting	Pr. Pt. S. T	10	1~32	-																																																																												
		<table border="1" style="width: 100%; border-collapse: collapse; text-align: center;"> <thead> <tr> <th>Response level</th> <th>Rigidity</th> <th>Response frequency</th> <th>Response level</th> <th>Rigidity</th> <th>Response frequency</th> </tr> </thead> <tbody> <tr> <td>1</td> <td rowspan="6">low</td> <td>10.0 Hz</td> <td>17</td> <td rowspan="6">middle</td> <td>67.1</td> </tr> <tr> <td>2</td> <td>11.3 Hz</td> <td>18</td> <td>75.6</td> </tr> <tr> <td>3</td> <td>12.7 Hz</td> <td>19</td> <td>85.2</td> </tr> <tr> <td>4</td> <td>14.3 Hz</td> <td>20</td> <td>95.9</td> </tr> <tr> <td>5</td> <td>16.1 Hz</td> <td>21</td> <td>108.0</td> </tr> <tr> <td>6</td> <td>18.1 Hz</td> <td>22</td> <td>121.7</td> </tr> <tr> <td>7</td> <td rowspan="6">middle</td> <td>20.4 Hz</td> <td>23</td> <td rowspan="6">high</td> <td>137.1</td> </tr> <tr> <td>8</td> <td>23.0 Hz</td> <td>24</td> <td>154.4</td> </tr> <tr> <td>9</td> <td>25.9 Hz</td> <td>25</td> <td>173.9</td> </tr> <tr> <td>10</td> <td>29.2 Hz</td> <td>26</td> <td>195.9</td> </tr> <tr> <td>11</td> <td>32.9 Hz</td> <td>27</td> <td>220.6</td> </tr> <tr> <td>12</td> <td>37.0 Hz</td> <td>28</td> <td>248.5</td> </tr> <tr> <td>13</td> <td rowspan="4">middle</td> <td>41.7 Hz</td> <td>29</td> <td rowspan="4">high</td> <td>279.9</td> </tr> <tr> <td>14</td> <td>47.0 Hz</td> <td>30</td> <td>315.3</td> </tr> <tr> <td>15</td> <td>52.9 Hz</td> <td>31</td> <td>355.1</td> </tr> <tr> <td>16</td> <td>59.6 Hz</td> <td>32</td> <td>400.0</td> </tr> </tbody> </table>	Response level	Rigidity	Response frequency	Response level	Rigidity	Response frequency	1	low	10.0 Hz	17	middle	67.1	2	11.3 Hz	18	75.6	3	12.7 Hz	19	85.2	4	14.3 Hz	20	95.9	5	16.1 Hz	21	108.0	6	18.1 Hz	22	121.7	7	middle	20.4 Hz	23	high	137.1	8	23.0 Hz	24	154.4	9	25.9 Hz	25	173.9	10	29.2 Hz	26	195.9	11	32.9 Hz	27	220.6	12	37.0 Hz	28	248.5	13	middle	41.7 Hz	29	high	279.9	14	47.0 Hz	30	315.3	15	52.9 Hz	31	355.1	16	59.6 Hz	32	400.0				
Response level	Rigidity	Response frequency	Response level	Rigidity	Response frequency																																																																													
1	low	10.0 Hz	17	middle	67.1																																																																													
2		11.3 Hz	18		75.6																																																																													
3		12.7 Hz	19		85.2																																																																													
4		14.3 Hz	20		95.9																																																																													
5		16.1 Hz	21		108.0																																																																													
6		18.1 Hz	22		121.7																																																																													
7	middle	20.4 Hz	23	high	137.1																																																																													
8		23.0 Hz	24		154.4																																																																													
9		25.9 Hz	25		173.9																																																																													
10		29.2 Hz	26		195.9																																																																													
11		32.9 Hz	27		220.6																																																																													
12		37.0 Hz	28		248.5																																																																													
13	middle	41.7 Hz	29	high	279.9																																																																													
14		47.0 Hz	30		315.3																																																																													
15		52.9 Hz	31		355.1																																																																													
16		59.6 Hz	32		400.0																																																																													

No	Abbr.	Function description	Control Mode	Initial Value	Setting range	unit									
PA04	HMOV	Home moving option: <table border="1" style="margin-left: 20px;"> <tr> <td>0</td> <td>z</td> <td>y</td> <td>x</td> </tr> </table>	0	z	y	x	Pr	0000h	0000h ~ 0128h	-					
		0	z	y	x										
		<table border="1" style="margin-left: 20px;"> <tr> <th>z</th> <th>y</th> <th>x</th> </tr> <tr> <td>Limit setting</td> <td>Z signal setting</td> <td>Home moving option</td> </tr> <tr> <td>0~1</td> <td>0~2</td> <td>0~8</td> </tr> </table>	z	y	x	Limit setting					Z signal setting	Home moving option	0~1	0~2	0~8
		z	y	x											
Limit setting	Z signal setting	Home moving option													
0~1	0~2	0~8													
When reach limit : z=0: Error z=1: direction reverse	y=0 : motor turns back to last Z pulse to attain y=1 : motor goes ahead to next Z pulse to attain y=2 : origin recognized right away	x=0: Home return in CW rotation, LSP is origin. x=1: Home return in CCW rotation, LSN is origin. x=2: Home return in CW rotation, OGRP: OFF → ON is origin. x=3: Home return in CCW rotation, OGRP: OFF → ON is origin. X=4: CW rotation to find z pulse as origin. X=5: CCW rotation to find z pulse as origin.													
y=0 : motor turns back to last Z pulse to attain y=1 : motor goes ahead to next Z pulse to attain y=2 : origin recognized right away	x=6: Home return in CW rotation, OGRP: ON → OFF is origin. x=7: Home return in CCW rotation, OGRP: ON → OFF is origin. x=8: Directly define current position as the origin.														
PA05	TL1	Inner torque limit 1 : Motor generated torque is restricted by this parameter which unit is %. The generated torque is calculated as below. Torque limit value = maximum torque *PA05 TL signal is used to select PA05 or analog TLA as limit value. TL1 signal enables the PC25 to compare with PA05 or TLA.	Pr. Pt S. T	100	0 ~ 100	%									
		If the TL1 and SG are open-circuit, the valid torque limit is: <table border="1" style="margin-left: 20px;"> <tr> <th>TL-SG</th> <th>The valid torque limit</th> </tr> <tr> <td>open-circuit</td> <td>torque limit =PA 05</td> </tr> <tr> <td>short-circuit</td> <td>If TLA<PA 05, torque limit = TLA If TLA>PA 05, torque limit = PA 05</td> </tr> </table>					TL-SG	The valid torque limit	open-circuit	torque limit =PA 05	short-circuit	If TLA<PA 05, torque limit = TLA If TLA>PA 05, torque limit = PA 05			
		TL-SG					The valid torque limit								
		open-circuit					torque limit =PA 05								
short-circuit	If TLA<PA 05, torque limit = TLA If TLA>PA 05, torque limit = PA 05														
If the TL1 and SG are short-circuit, the valid torque limit is: <table border="1" style="margin-left: 20px;"> <tr> <th>TL-SG</th> <th>The valid torque limit</th> </tr> <tr> <td>open-circuit</td> <td>If PC 25<PA 05, torque limit = PC 25 If PC 25>PA 05, torque limit = PA 05</td> </tr> <tr> <td>short-circuit</td> <td>If PC 25<TLA, torque limit = PC 25 If PC 25>TLA, torque limit = TLA</td> </tr> </table>	TL-SG	The valid torque limit	open-circuit	If PC 25<PA 05, torque limit = PC 25 If PC 25>PA 05, torque limit = PA 05	short-circuit	If PC 25<TLA, torque limit = PC 25 If PC 25>TLA, torque limit = TLA									
TL-SG	The valid torque limit														
open-circuit	If PC 25<PA 05, torque limit = PC 25 If PC 25>PA 05, torque limit = PA 05														
short-circuit	If PC 25<TLA, torque limit = PC 25 If PC 25>TLA, torque limit = TLA														
PA06	CMX	Electronic gear numerator	Pr. Pt	1	1 ~ 2 ²⁶	-									

PA07	CDV (▲)	<p>Electronic gear denominator The improper setting could lead to unexpected fast rotation so make sure to set them in the state of SERVO OFF. The proper range setting is:</p> $\frac{\text{Pulse command input}}{f1} \rightarrow \frac{CMX}{CDV} \rightarrow \frac{\text{Position command}}{f2=f1 \cdot \frac{CMX}{CDV}}$ <p>Note : limit condition : $1/50 < (CMX/CDV) < 64000$</p>	Pr. Pt	1	1 ~ 2 ²⁶	-								
PA08	HSPD1	<p>Home moving high speed option 1</p>	Pr	100	1 ~ 2000	rpm								
PA09	HSPD2	Home moving high speed option 2	Pr	20	1 ~ 500	rpm								
PA10	RES1	<p>Regenerative resistor value</p> <table border="1"> <thead> <tr> <th>Drive capacity</th> <th>Default</th> </tr> </thead> <tbody> <tr> <td>Under 500W</td> <td>100Ω</td> </tr> <tr> <td>750W~1KW</td> <td>40Ω</td> </tr> <tr> <td>1.5KW~3.5KW</td> <td>13Ω</td> </tr> </tbody> </table>	Drive capacity	Default	Under 500W	100Ω	750W~1KW	40Ω	1.5KW~3.5KW	13Ω	Pr. Pt S. T	According to spec, please refer to the table left.	10 ~ 750	Ohm
Drive capacity	Default													
Under 500W	100Ω													
750W~1KW	40Ω													
1.5KW~3.5KW	13Ω													
PA11	RES2	<p>Regenerative resistor capacity</p> <table border="1"> <thead> <tr> <th>Drive capacity</th> <th>Default</th> </tr> </thead> <tbody> <tr> <td>Under 500W</td> <td>20W</td> </tr> <tr> <td>750W~1KW</td> <td>40W</td> </tr> <tr> <td>1.5KW~3.5KW</td> <td>100W</td> </tr> </tbody> </table>	Drive capacity	Default	Under 500W	20W	750W~1KW	40W	1.5KW~3.5KW	100W	Pr. Pt S. T	According to spec, please refer to the table left.	0 ~ 3000	Watt
Drive capacity	Default													
Under 500W	20W													
750W~1KW	40W													
1.5KW~3.5KW	100W													
PA12	INP	<p>In-position range : To define the permissible pulse error range of position pulse commands. As positioning operation done, the INP signal of DO would output.</p>	Pt. Pr	41943	0 ~ 2 ²²	pulse								

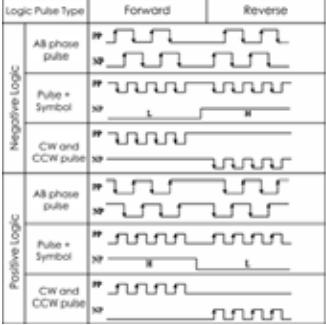
PA13	PLSS (*)	<p>Pulse command option : Setting value of Control mode option:</p> <table border="1" data-bbox="331 248 520 282"> <tr> <td>u</td> <td>z</td> <td>y</td> <td>x</td> </tr> </table> <p><u>x</u> : pulse-train format select x=0 : forward/reverse rotation pulse train x=1 : pulse train + sign x=2 : A/B phase pulse train</p> <p><u>y</u> : acknowledged logic y=0 : positive logic y=1 : negative logic</p>  <p><u>z</u> : input pulse filter option 0 : Pulse frequency 500kpps or less (u=0) 1 : Pulse frequency 200kpps or less (u=0) 0 : Pulse frequency 4000kpps or less (u=1) 1 : Pulse frequency 1000kpps or less (u=1)</p> <p><u>u</u> : pulse input hardware option u=0 : Normal speed port (CN1, PP、PG、NP、NG) u=1 : High speed port (CN1, HPP、HPG、HNP、HNG)</p>	u	z	y	x	Pt	0000h	0000h ~ 1112h	-
u	z	y	x							
PA14	ENR (*)	<p>Encoder output pulses Used to set the A/B-phase pulses encoder output by the drive. Users could use parameter PA39 to choose the output pulse setting or output division ratio setting. Set the value 4 times greater than the A-phase or B-phase pulses. The number of A/B-phase pulses actual output is 1/4 times. The maximum output frequency is 20MHz. (after multiplication by 4). Use this parameter within this range.</p> <p>For output pulse setting Set "□0□□" (initial value) in parameter PA39. Set the number of pulses per servo motor revolution. If PA39=0000h and PA14=1024, the actual output pulses per motor revolution is 1024.</p> <p>For output division ratio setting Set "□1□□" in parameter PA39. Set the output division ratio (PA14) per motor revolution.</p> $Output\ pulses = \frac{PA14\ setting\ value}{resolution\ per\ motor\ revolution}$ <p>If PA39=0100h and PA14=512, the actual output pulses per motor revolution is (222/512) =8192.</p>	Pr.Pt S.T	10000	4 ~ 2 ²²	Pulse/ rev				

No	Abbr.	Function description	Control Mode	Initial Value	Setting range	unit				
PA15	CRSHA	Motor crash protection level (percentage) Used to prevent the motor running from crashing the mechanical equipment. If PA15 is 0, the function is disabled. Any non-zero value setting will enable this function.	Pr.Pt S.T	0	0~300	%				
PA16	CRSHT	Motor crash protection (time) When the PA15 level is reached after the PA16 setting time taken, the AL20 will occur.	Pr.Pt S.T	1	0 ~ 1000	ms				
PA17	OVL	Output overload warning level Used to set output overload level. If PA17 setting is within 0~100, when the motor has reached this level, a warning will be activated. If PA17 setting exceeds 100, the function is disabled.	Pr.Pt S.T	120	0 ~ 120	%				
PA18	OVS	Over speed warning When the motor feedback speed exceeds this PA18 setting, the AL06 will occur.	Pr.Pt S.T	5500	1 ~ 6000	rpm				
PA19	OVPE	Position error excess When the position error exceeds this PA19 setting, the AL08 will occur.	Pr.Pt	3×2^{22}	$1 \sim 2^{31}-1$	pulse				
PA20	OVPL1 (*)	Position pulse frequency excess level 1 When PA13 is set as 0□□□ and the position command pulse frequency exceeds this PA20 setting, the AL07 will occur.	Pt	530	100 ~ 600	KHz				
PA21	OVPL2 (*)	Position pulse frequency excess level 2 When PA13 is set as 1□□□ and the position command pulse frequency exceeds this PA20 setting, the AL07 will occur.	Pt	4500	1000 ~ 5000	KHz				
PA22	DBF (*)	Dynamic brake control Used to enable or disable the dynamic brake if an alarm occurred. 0: DBF enabled, the motor stops immediately. 1: DBF disabled, the motor coasts to stop gradually.	Pr.Pt S.T	0	0~1	-				
PA23	MCS (■)	Memory write-inhibit function Used to permit or prohibit memory-write. 0:EEPROM is writable. 1:EEPROM is prohibited to be written. Parameter modification will vanish after power off.	Pr.Pt S.T	0	0~1	-				
PA24	PRES (*)	Linear scale resolution of full-closed loop Used to set the A/B quadrature phase pulses (4x) for full-closed control per motor revolution.	Pr.Pt	5000	200 ~ 2^{22}	pulse				
PA25	PERR	Error protection range of full-closed loop When the position error of linear scale A/B phase feedbacked and the motor encoder feedbacked exceeds this PA25 setting, the AL23 will occur.	Pr.Pt	30000	1 ~ $(2^{31}-1)$	pulse				
PA26	FCON (▲)	Full-closed loop control option : <table border="1" style="margin-left: 20px;"> <tr> <td>0</td> <td>z</td> <td>y</td> <td>x</td> </tr> </table> x : switch of full-close loop 0 : invalid 1 : full-close loop control is valid 2 : couple synchronous motion is valid y : pulse output source option (LA/LB/LZ) 0 : motor encoder 1 : linear scale A/B phase counter z : positive or negative direction option of linear scale 0 : A phase leads B phase means the positive direction 1 : B phase leads A phase means the positive direction	0	z	y	x	Pr.Pt	0000h	0000h ~ 0112h	-
0	z	y	x							
PA27	FELP	Low-pass filter of full-closed loop If the mechanism rigidity of full-close loop control is insufficient, users can adjust this PA27 setting to enhance the stability of the mechanism. The more rigidity of full-closed mechanism, the less setting of PA27. "0" setting means this filter disabled(By pass).	Pr.Pt	100	0 ~ 1000	ms				

PA28	ABS (*)	Absolute encoder settings Used to permit that the motor with absolute encoder but is operated as an incremental motor. 0: Incremental mode. 1: Absolute mode. This setting is only available for the servo motor with absolute encoder, otherwise the AL24 will occur.-	Pr.Pt S.T	0000h	0000h ~ 0001h	-												
PA29	CAP (■)	Absolute homing position When the PA29 is set as 1, the current position will be set as origin position. This function is the same as the ABSC.	Pr.Pt S.T	0000h	0000h ~ 0001h	-												
PA30	UAP (■)	Update encoder absolute position Used to update the absolute position data of the encoder. 1: Update the encoder data to PA31~PA33 only 2: Update the PA31~PA33 and clear the position error as well. As this setting is activated, the current position of the motor will be reset as the goal of position command.	Pr.Pt S.T	0	0 ~ 2	-												
PA31	APST	<p>Absolute coordinate system state (read only)</p> <table border="1"> <tr> <td>bit15~bit5</td> <td>bit4</td> <td>bit3</td> <td>bit2</td> <td>bit1</td> <td>bit0</td> </tr> <tr> <td>0</td> <td>0/1</td> <td>0</td> <td>0/1</td> <td>0/1</td> <td>0/1</td> </tr> </table> <p>bit0 : absolute position status 0 : normal 1 : absolute position has lost</p> <p>bit1 : battery voltage level 0 : normal 1 : low voltage</p> <p>bit2 : encoder turns excess 0 : normal 1 : overflow</p> <p>bit3 : reserved</p> <p>bit4 : absolute coordinate system state 0 : normal 1 : absolute coordinate system has not yet been set</p> <p>bit5~bit15 : reserved</p>	bit15~bit5	bit4	bit3	bit2	bit1	bit0	0	0/1	0	0/1	0/1	0/1	Pr.Pt S.T	0	0000h ~ 001Fh	-
bit15~bit5	bit4	bit3	bit2	bit1	bit0													
0	0/1	0	0/1	0/1	0/1													
PA32	APR	Encoder absolute position (pulse) (read only) To display the absolute encoder pulse number. This parameter is valid only when the PA28 is set as 1.	Pr.Pt S.T	0	0~4194303	pulse												
PA33	APP	Encoder absolute position (rev) (read only) To display the absolute encoder turn number. This parameter is valid only when the PA28 is set as 1.	Pr.Pt S.T	0	32767~ -32768	rev												
PA34	ABSM (*)	I/O communication of absolute system 0 : Delta PLC is applied 1 : Mitsubishi PLC is applied	Pr.Pt S.T	0	0 ~ 1	-												
PA35 ~ PA38	reserved																	

PA39	POL (*)	<p>Motor rotary direction option</p> <p>The relation among motor rotary direction and input command pulse-train direction and encoder output pulse direction is described below.</p> <table border="1"> <tr> <td>0</td> <td>z</td> <td>y</td> <td>x</td> </tr> </table> <p>x : input pulse-train and motor rotary direction option</p> <table border="1"> <thead> <tr> <th rowspan="2">x</th> <th colspan="2">motor rotary direction</th> </tr> <tr> <th>forward pulse-train input</th> <th>reverse pulse-train input</th> </tr> </thead> <tbody> <tr> <td>0</td> <td>CCW</td> <td>CW</td> </tr> <tr> <td>1</td> <td>CW</td> <td>CCW</td> </tr> </tbody> </table> <p>y : motor rotary direction and encoder pulse output option</p> <table border="1"> <thead> <tr> <th>y</th> <th>motor CCW rotation</th> <th>motor CW rotation</th> </tr> </thead> <tbody> <tr> <td>0</td> <td> </td> <td> </td> </tr> <tr> <td>1</td> <td> </td> <td> </td> </tr> </tbody> </table> <p>z : encoder output option 0 : output pulse 1 : output division ratio This parameter is related to PA 14</p>	0	z	y	x	x	motor rotary direction		forward pulse-train input	reverse pulse-train input	0	CCW	CW	1	CW	CCW	y	motor CCW rotation	motor CW rotation	0			1			Pt.S. T	0000h	0000h ~ 0111h	-																																
0	z	y	x																																																											
x	motor rotary direction																																																													
	forward pulse-train input	reverse pulse-train input																																																												
0	CCW	CW																																																												
1	CW	CCW																																																												
y	motor CCW rotation	motor CW rotation																																																												
0																																																														
1																																																														
PA40	SPW (▲)	<p>Special parameter write-enable : As this parameter is set as 0088h, the drive would take 2 seconds to recover factory-set. This change is valid by power off once and power on again.</p>	Pr.Pt S.T	0000h	0000h ~ 00FFh	-																																																								
PA41	POSPD	<p>Max. speed output setting of encoder According to the actual application, users can set this PA41 to optimize the encoder outputs (LA, LB). If this setting value is exceeded during the motor running, the AL30 will occur. "0" is to disable this function.</p>	Pr.Pt S.T	5500	0 ~ 6000	rpm																																																								
PA42	BLK (*)	<p>Parameter read/write inhibit option</p> <table border="1"> <thead> <tr> <th>PA42</th> <th>PA□□</th> <th>PB□□</th> <th>PC□□</th> <th>PD□□</th> <th>PE□□</th> <th>PF□□</th> </tr> </thead> <tbody> <tr> <td>0000h</td> <td></td> <td></td> <td></td> <td>⊙</td> <td></td> <td></td> </tr> <tr> <td>0001h</td> <td></td> <td></td> <td>⊙</td> <td></td> <td></td> <td>X</td> </tr> <tr> <td>0002h</td> <td></td> <td>⊙</td> <td></td> <td></td> <td></td> <td>X</td> </tr> <tr> <td>0003h</td> <td></td> <td>⊙</td> <td></td> <td></td> <td>X</td> <td></td> </tr> <tr> <td>0004h</td> <td>⊙</td> <td></td> <td></td> <td>X</td> <td></td> <td></td> </tr> <tr> <td>0005h</td> <td>⊙</td> <td></td> <td>X</td> <td></td> <td></td> <td></td> </tr> <tr> <td>0006h</td> <td colspan="6">X, but PA42 is excepted it is writable.</td> </tr> </tbody> </table> <p>⊙ : R/W enable, ○ : R enable W inhibit, X : R/W inhibit Note: When the parameter group is assigned to R/W inhibit, it mean that the display will not show.</p>	PA42	PA□□	PB□□	PC□□	PD□□	PE□□	PF□□	0000h				⊙			0001h			⊙			X	0002h		⊙				X	0003h		⊙			X		0004h	⊙			X			0005h	⊙		X				0006h	X, but PA42 is excepted it is writable.						Pr.Pt S.T	0000h	0000h ~ 00FFh	-
PA42	PA□□	PB□□	PC□□	PD□□	PE□□	PF□□																																																								
0000h				⊙																																																										
0001h			⊙			X																																																								
0002h		⊙				X																																																								
0003h		⊙			X																																																									
0004h	⊙			X																																																										
0005h	⊙		X																																																											
0006h	X, but PA42 is excepted it is writable.																																																													
PA43	ENB (*)	<p>Encoder type option Set PA43 as 0, when the 20bit resolution encoder is used Set PA43 as 1, when the 22bit resolution encoder is used Set PA43 as 2, when the 23bit resolution encoder is used</p>	Pr.Pt S.T	0001h	0000h ~ 0002h	-																																																								

No	Abbr.	Function description	Control Mode	Initial Value	Setting range	unit
PA44	EGM (*)	<p>Electronic gear ratio mode</p> <p>0 : normal, ratio=PA06/PA07 1 : ratio conversion 1, ratio= encoder resolution/ PA45 2 : ratio conversion 2, ratio= 2 x PA06/PA07, PA19= PA19 x 2, it is suitable for 22bit to 23bit conversion</p> <p>Here is an explanation diagram : FBP is the setting value of PA45 ; Pt is the resolution pulse of per turn</p>	Pr.Pt	0	0 ~ 2	-
PA45	FBP (*)	Position command pulse per revolution Used to set the position command pulse number per revolution when the PA44 is set as 1.	Pr.Pt	10000	10 ³ ~ 10 ⁶	pulse
PA46 ~ PA50		Reserved				

No	Abbr.	Function description	Control Mode	Initial Value	Setting range	unit
PB01	NHF1	<p>Machine resonance suppression filter 1 To set a specific frequency which the control gain is decreased to suppress the mechanism resonance. Refer to section 6.3.6.</p>	Pr.Pt S.T	1000	10 ~ 4000	Hz
PB02	NHD1	Machine resonance suppression attenuation 1 To set the attenuation at the PB01 frequency. The setting of "0" value denotes the disabled of this notch filter.	Pr.Pt S.T	0	0 ~ 32	dB
PB03	NLP	Resonance suppression low-pass filter To set low-pass filter time constant for suppress resonance	Pr.Pt S.T	10	0 ~ 10000	0.1ms
PB04	PST	<p>Position command filter time constant Used to smooth the running of motor in position control mode. See section 6.4.3 for more details.</p> <p>The time to reach actual target position is 5time of PST.</p>	Pt. Pr	3	0 ~ 20000	ms
PB05	FFC	Position feed-forward gain To reduce the position error and position settling time, but if the value is set too large, a sudden acceleration or deceleration may cause overshoots.	Pt. Pr	0	0 ~ 200	%

PB06	GD1	The ratio of load inertia to motor shaft (load inertia ratio) Set the load inertia ratio value on the servo motor. When the auto tuning mode (PA02) set to "1", then adjusting result will be set in this parameter automatically.	Pr. Pt. S. T	70	0 ~ 1200	0.1time				
PB07	PG1	Position loop gain : Used to decide response level of position loop. Increasing PG1 improves traceability, but a too high value makes overshooting or vibration occurred. When auto-gain tuning mode is applied, PB07 would be set according to the result of inertia estimation.	Pt. Pr	45	4 ~ 1024	rad/s				
PB08	VG1	Speed loop gain Increasing VG1 improves traceability to a speed command but a too high value will make machine resonance. When auto-gain tuning mode is applied, PB08 would be set according to the result of gain tuning.	Pt. Pr S	183	40 ~ 9000	rad/s				
PB09	VIC	Speed integral gain The PB09 is used to eliminate stationary deviation against a command.	Pt Pr. S	34	1 ~ 1000	ms				
PB10	VFG	Speed feed-forward gain To set the proper gain would reduce the tracking time of speed command. Also, a too big value would cause overshoots during the sudden acceleration/deceleration command.	S	0	0 ~ 200	%				
PB11	CDP (*)	Gain switch option <table border="1" style="margin-left: 20px;"> <tr> <td>0</td> <td>0</td> <td>0</td> <td>x</td> </tr> </table> <ul style="list-style-type: none"> x=0 : Turn off gain switch x=1 : Gain switched as the CDP signal of DI is ON x=2 : Position command frequency >= CDS(PB12) setting x=3 : Position command pulse error >= CDS(PB12) setting x=4 : Motor speed >= CDS(PB12) setting x=5 : Gain switched as the CDP signal of DI is OFF x=6 : Position command frequency <= CDS(PB12) setting x=7 : Position command pulse error <= CDS(PB12) setting x=8 : Motor speed <= CDS(PB12) setting 	0	0	0	x	Pt. Pr S	0000h	0000h ~ 0008h	-
0	0	0	x							
PB12	CDS	Gain switch condition value The unit of CDS value is varied (kpps, pulse, rpm) according to the settings of CDP.	Pt. Pr S	10	0 ~ 4000000	kpps pulse rpm				
PB13	CDT	Gain switch time constant Used to smooth the motor running at gain switching. Used to set up time constant when CDP switches to CDS.	Pt. Pr S	1	0 ~ 1000	ms				
PB14	GD2	The ratio 2 of load inertia to motor shaft Set the demand ratio of load inertia to motor shaft after switching. This value is valid as gain switch function preformed.	Pt. Pr S	70	0 ~ 1200	0.1 time				
PB15	PG2	Position loop gain change ratio The gain values would be changed as: gain after switched = (PG1 or VG1 or VIC) x PB15 (%) These changes are valid only if auto-gain tuning disabled.	Pt. Pr	100	10 ~ 500	%				
PB16	VG2	Speed loop gain change ratio These changes are valid only if auto-gain tuning disabled.	Pt.Pr. S	100	10 ~ 500	%				
PB17	VIC2	Speed integral gain change ratio : These changes are valid only if auto-gain tuning disabled.	Pt.Pr S	100	10 ~ 500	%				
PB18	SFLT	Speed low-pass filter smooth time constant : Larger value would make the response slow down obviously. If it is set as zero, this function is disabled.  The required time to catch the command is 5-time of SELT.	S. T	0	0 ~ 1000	ms				

No	Abbr.	Function description	Control Mode	Initial Value	Setting range	unit
PB19	TQC	Torque command filter time constant : Larger value would make the response slow down obviously. If it is set as zero, this function is disabled.  The required time to catch the command is 5-time of TQC.	T	0	0 ~ 5000	ms
PB20	SJIT	Speed feedback filter time constant Used to set the filter time constant of motor speed feedback.	Pr.Pt S.T	0	0 ~ 1000	0.1ms
PB21	NHF2	Machine resonance suppression filter 2 : The secondary option of notch filter frequency to suppress the mechanism resonance.	Pr.Pt S.T	1000	10 ~ 4000	Hz
PB22	NHD2	Machine resonance suppression attenuation 2 : The secondary option of notch filter attenuation. 0 is setting for turning off the function of Notch filter.	Pr.Pt S.T	0	0 ~ 32	dB
PB23		Reserved				
PB24	VDC	Speed differential compensation : Used to set the Speed differential compensation. It is valid only if digital terminals input is "ON".	Pr.Pt S	980	0 ~ 1000	-
PB25	NHF3	Machine resonance suppression filter 3 : The third option of notch filter frequency to suppress the mechanism resonance.	Pr.Pt S.T	1000	10 ~ 4000	Hz
PB26	NHD3	Machine resonance suppression attenuation 3 : The third option of notch filter attenuation. 0 is setting for turning off the function of Notch filter.	Pr.Pt S.T	0	0 ~ 32	dB
PB27	ANCF	Auto-resonance suppression mode setting(for machine resonance suppression filter 1&2) Setting value is 0 : Stable Setting value is 1 : Stable after resonance suppression Setting value is 2 : Continuous resonance suppression	Pr.Pt S.T	1	0 ~ 2	-
PB28	ANCL	Resonance suppression detection level The smaller the setting value is, the more sensitive the resonance will be.	Pr.Pt S.T	50	1 ~ 300	%
PB29	AVSM	Auto low frequency resonance suppression mode setting: Setting value is 0 : Stable Setting value is 1 : Stable after resonance suppression Description: When it is set to 1: Auto resonance, the value returns to 0 automatically and saves the point of resonance suppression to PB31 (VSF1) when it is stable.	Pr.Pt	0	0 ~ 1	-
PB30	VCL	Low frequency resonance suppression detection level When PB29 is set to 1, low frequency resonance suppression is on. The lower value of Low frequency resonance suppression detection level is, the more sensitive the detection will be, but misjudge the noise or other not main low frequency resonance easily. The higher the value is, the more correct the judge is. But if the machine resonance is too small, the lower value is hard to search for low-frequency resonance.	Pr.Pt	50	1 ~ 8000	pulse
PB31	VSF1	Low-frequency vibration suppression 1 The setting value of the first low-frequency vibration suppression. If PB32 is set to 0, then it will disable the first low-frequency filter.	Pr.Pt	100	1 ~ 3000	0.1Hz
PB32	VSG1	Low-frequency vibration suppression gain 1 The bigger value it is, the better the position response will be. However, if the value is set too big, the motor will not be able to smoothly operate. It is suggested to set the value to 1	Pr.Pt	0	0 ~ 15	-
PB33	VSF2	Low-frequency vibration suppression 2 The setting value of the second low-frequency vibration suppression. If PB34 is set to 0, then it will disable the second low-frequency filter.	Pr.Pt	100	1 ~ 3000	0.1Hz

PB34	VSG2	Low-frequency vibration suppression gain 2 The second low-frequency vibration suppression gain. The bigger value it is, the better the position response will be. However, if the value is set too big, the motor will not be able to smoothly operate. It is suggested to set the value to 1.	Pr.Pt	0	0 ~ 15	-
PB35	FRCL	Friction Compensation The level of friction compensation (the percentage of rated torque. Set the value to 0 means to disable the function; set the value to 1 or number above means to enable it.)	Pr.Pt S	0	0 ~ 100	%
PB36	FRCT	Friction compensation smoothing time constant The setting value of the friction compensation smoothing time constant.	Pr.Pt S	0	0 ~ 1000	ms
PB37	FRCM	Friction compensation option When setting value is 0 : Speed <PC17, the value of Friction compensation option retains. When setting value is 1 : Speed <PC17, the value of Friction compensation option converges to 0 °	Prep S	0	0 ~ 1	-
PB38	FFCT	Position feed forward filter time constant The setting value of the position feed forward filter time constant.	Pr.Pt	0	0 ~ 1000	0.1ms
PB39	SVP (▲)	Synchronous motion speed gain With this value increases will enhance the two motors speed follow, but cause into vibration and noise.	Pr.Pt S.T	0	0 ~ 8191	rad/s
PB40	SVI (▲)	Synchronous motion speed integral compensation With this value increases will enhance the two motors speed follow and close speed between two motor errors, but cause into vibration and noise.	Pr.Pt S.T	0	0 ~ 1023	rad/s
PB41	SPI (▲)	Synchronous motion position integral compensation With this value increases will enhance the two motors speed follow and close speed between two motor errors, but cause into vibration and noise. It is suggested to set the value to the same value of PB09.	Pr.Pt S.T	0	0 ~ 1023	rad
PB42	SBW (▲)	Synchronous motion control bandwidth If users do not know how to design PB39~PB41, through setting of this value to design bandwidth, which corresponds to PB39~PB41. When the synchronous motion control bandwidth is greater than servo bandwidth the better traceability is. But when the speed loop bandwidth + synchronous motion control bandwidth > system allowed bandwidth, it can cause the resonance. When increasing the speed loop bandwidth and synchronous motion control bandwidth, please note that PB03 react far faster than the bandwidth of the two designs.	Pr.Pt S.T	0	0 ~ 1023	Hz
PB43	SVL	Synchronous motion speed error filter constant As with motion control because of the influence of low resolution making noise (less sharp and rough sound), you can set the low-pass filter suppression should be noted that bandwidth must be much faster than the motion control design.	Pr.Pt S.T	0	0 ~ 1000	0.1ms
PB44 ~ PB50	Reserved					

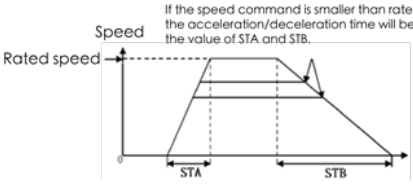
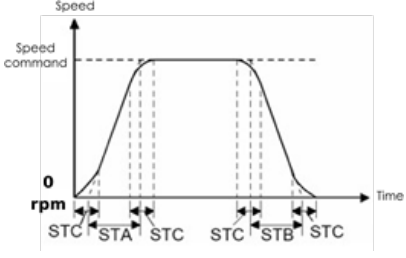
No	Abbr.	Function description	Control Mode	Initial Value	Setting range	unit
PC01	STA	<p>Acceleration time constant This parameter is the time spent for the motor from 0 rpm to the rated speed and it is defined as "acceleration time constant". For example, if the rated speed of the servo motor is 3000 rpm and this parameter is set as 3000 (3s). In such case, the motor accelerating from 0 rpm to 3000 rpm would take 3 seconds. When the speed command is set at 1000 rpm, the motor take 1 second to accelerate from 0 rpm to 1000 rpm. Set the acceleration time by the PC01 when in JOG mode. See section 6.4.3 for more details.</p> 	S.T	200	0 ~ 20000	ms
PC02	STB	<p>Deceleration time constant The time spent for the motor to decelerate from the rated speed to 0 rpm is called "deceleration time constant". See section 6.4.3 for more details. Set the deceleration time by the PC02 when in JOG mode.</p>	S.T	200	0 ~ 20000	ms
PC03	STC	<p>S-pattern acceleration/deceleration time constant The S-pattern acceleration/deceleration function is to employ a three-step curve of acceleration or deceleration moving to soothe the vibration during starting or stopping the motor. Setting an appropriate STC could improve the stability of the motor during startup and stop In order to smooth the command curve, the acceleration time and deceleration time there will be a little error. Motor acceleration time to the speed command = STA + STC Motor deceleration time from the speed command to 0 = STB + STC</p> 	Pr S.T	0	0 ~ 10000	ms
PC04	JOG	<p>JOG speed command As JOG mode applied, this PC04 is used as speed command.</p>	Pr.Pt S.T	300	0 ~ 4500	rpm
PC05	SC1	<p>Inner speed command/limit 1 For speed control, PC05 is used as inner speed command 1. For torque control, PC05 is the speed limit and directionless. The maximum value of speed command 1 is the motor highest speed.</p>	S.T	100	-4500 ~ 4500	rpm
PC06	SC2	<p>Inner speed command/limit 2 For speed control, PC06 is used as inner speed command 2. For torque control, PC06 is the speed limit and directionless. The maximum value of speed command 1 is the motor highest speed.</p>	S.T	500	-4500 ~ 4500	rpm
PC07	SC3	<p>Inner speed command/limit 3 For speed control, PC07 is used as inner speed command 3. For torque control, PC07 is the speed limit and directionless. The maximum value of speed command 1 is the motor highest speed.</p>	S.T	1000	-4500 ~ 4500	rpm
PC08	SC4	<p>Inner speed command/limit 4 For speed control, PC08 is used as inner speed command 4. For torque control, PC08 is the speed limit and directionless. The maximum value of speed command 1 is the motor highest speed.</p>	S.T	200	-4500 ~ 4500	rpm

No	Abbr.	Function description	Control Mode	Initial Value	Setting range	unit				
PC09	SC5	Inner speed command/limit 5 For speed control, PC09 is used as inner speed command 5. For torque control, PC09 is the speed limit and directionless. The maximum value of speed command 1 is the motor highest speed.	S.T	300	-4500 ~ 4500	rpm				
PC10	SC6	Inner speed command/limit 6 For speed control, PC10 is used as inner speed command 6. For torque control, PC10 is the speed limit and directionless. The maximum value of speed command 1 is the motor highest speed.	S.T	500	-4500 ~ 4500	rpm				
PC11	SC7	Inner speed command/limit 7 For speed control, PC11 is used as inner speed command 7. For torque control, PC11 is the speed limit and directionless. The maximum value of speed command 1 is the motor highest speed.	S.T	800	-4500 ~ 4500	rpm				
PC12	VCM (▲)	Output speed of maximum analog command This value decides the output speed while the maximum permissible voltage (10V) is applied. For example, if the setting is 2000, when the external voltage input is 5V, it means the speed control command is 1000r/min. The formula is as follows : output speed == PC12* applied voltage of speed command/10 In torque mode, analog speed limit inputs the swing speed limit setting of the max. voltage. The formula is as follows : Speed limit command= PC12* input voltage value/10	S	3000	0 ~ 30000	rpm				
			T	3000	0 ~ 30000	rpm				
PC13	TLC (▲)	Torque generated of maximum analog command This value decides the output torque while the maximum permissible voltage (10V) is applied. For example, if the setting is 100, when the external voltage input is 10V, it means the torque control command is 100%; when the external voltage input is 5V, it means the torque control command is 50%. The formula is as follows : Torque command == PC13* applied voltage of torque command/10 See section 6.3.4 for more details.	T	100	0 ~ 2000	%				
			Pr.Pt S							
PC14	MOD	Analog monitor output There are 2 monitor outputs, ch1 and ch2. <table border="1" style="display: inline-table; vertical-align: middle;"> <tr> <td>0</td> <td>ch2</td> <td>0</td> <td>ch1</td> </tr> </table> The setting values and their corresponding output are listed below. 0 : Motor speed (scale: ±10V/(double rated speed)) 1 : Generated torque (scale: ±10V/max.torque) 2 : Speed command (scale: ±10V/(double rated speed)) 3 : Effective load ratio (scale: ±10V/±300%) 4 : Pulse command frequency (scale: ±10V/4300kpps) 5 : Current command (scale: ±10V/max.current command) 6 : DC Bus voltage (scale: ±10V/450V) 7 : Pulse command error(scale: ±10V/4194304pulse)	0	ch2	0	ch1	Pr.Pt S.T	0100h	0000h ~ 0707h	-
			0	ch2	0	ch1				
PC15	SVZR (*)	Speed analog zero voltage acknowledged range Treat the applied voltage which is less than PC15 as zero speed command.	S.T	10	0~1000	mv				
PC16	MBR	Electromagnetic brake output delay time The parameter PC16 could be used to decide the delay time of the SON signal off to the MBR signal activated.	Pr.Pt S.T	100	0 ~ 1000	ms				
PC17	ZSP	Zero speed acknowledged range As motor feedback speed is less than the setting value of PC17, the servo drive would treat it as zero speed and the ZSP of DO would be outputted.	Pr.Pt S.T	50	0 ~ 10000	rpm				

PC18	COP1 (*)	<p>Stop option and power interruption restart option</p> <table border="1"> <tr> <td>0</td> <td>0</td> <td>y</td> <td>x</td> </tr> </table> <p>x : power interruption restart option The voltage level drop would cause drive to alarm and stop. Auto-restart function could be applied by the setting of PC18. 0 : invalid 1 : valid</p> <p>y : motor stops option. Servo stops operation in speed command mode. y=1 : stops instantaneously y=0 : decelerates to stop</p>	0	0	y	x	Pr.Pt S.T	0010h	0000h ~ 0011h	-
0	0	y	x							
PC19	COP2 (*)	<p>Alarm history clear option</p> <table border="1"> <tr> <td>0</td> <td>0</td> <td>y</td> <td>x</td> </tr> </table> <p>x=0 : does not clear x=1 : to clear the histories after power off once and restart. The value will be set to 0 automatically after clear. y=0 : does not act when the alarm occurs. y=1 : Motor EMG when the alarm occurs.</p>	0	0	y	x	Pr.Pt S.T	0000h	0000h ~ 0011h	-
0	0	y	x							
PC20	SNO (*)	<p>Communication device number To set different device number for varied devices is necessary. If two drives occupy the same number, the communication could not be performed.</p>	Pr.Pt S.T	1	1 ~ 32	Device				
PC21	CMS (*)	<p>Communication mode option :</p> <table border="1"> <tr> <td>0</td> <td>0</td> <td>y</td> <td>x</td> </tr> </table> <p>y : communication reply delay time (changing parameter is valid after restart) y=0 : reply within 1 mS y=1 : reply after 1 mS</p> <p>x : mode option x=0 : RS-232C x=1 : RS-485</p>	0	0	y	x	Pr.Pt S.T	0010h	0000h ~ 0011h	-
0	0	y	x							
PC22	BPS (*)	<p>Communication protocol option :</p> <table border="1"> <tr> <td>0</td> <td>0</td> <td>y</td> <td>x</td> </tr> </table> <p>y : RS-485 or RS-232C transfer setting y=0 : 4800bps y=1 : 9600bps y=2 : 19200bps y=3 : 38400bps y=4 : 57600bps y=5 : 115200bps</p> <p>x : Communication protocol x=0 : 7,N,2(Modbus, ASCII) x=1 : 7,E,1(Modbus, ASCII) x=2 : 7,O,1(Modbus, ASCII) x=3 : 8,N,2(Modbus, ASCII) x=4 : 8,E,1(Modbus, ASCII) x=5 : 8,O,1(Modbus, ASCII) x=6 : 8,N,2(Modbus, RTU) x=7 : 8,E,1(Modbus, RTU) x=8 : 8,O,1(Modbus, RTU)</p>	0	0	y	x	Pr.Pt S.T	0010h	0000h ~ 0058h	-
0	0	y	x							
PC23	SIC	<p>Communication time-out process option Time-out inspection could be set from 1 to 60 seconds. If it is set as 0, the inspection function is invalid.</p>	Pr.Pt S.T	0	0 ~ 60	s				

PC24	DMD (*)	Status display option : <table border="1"> <tr> <td>0</td> <td>y</td> <td>x</td> </tr> </table> <p>x : display option after power on (Hexadecimal)</p> <ul style="list-style-type: none"> x=0 : Motor feedback pulse (High byte) (before electronic gear ratio) x=1 : Motor feedback revolution (Low byte) (before electronic gear ratio) x=2 : Cumulative pulses of command (High byte) (before electronic gear ratio) x=3 : Cumulative turns of command (Low byte) (before electronic gear ratio) x=4 : Accumulative pulses error (before electronic gear ratio) x=5 : Command pulse frequency x=6 : Motor speed x=7 : Speed analog command/limit voltage x=8 : Speed input command/limit x=9 : Torque analog command/limit voltage x=A : Torque input command/limit x=B : Effective load ratio x=C : Peak load ratio x=D : DC bus voltage x=E : The ratio of load inertia to motor shaft x=F : Instantaneous torque x=10 : Regenerative load rate x=11 : Full-close loop feedback pulse (High word) x=12 : Full-close loop feedback pulse (Low word) x=13 : 13 : Z phase reference absolute pulse <p>y : assigned display after power on</p> <ul style="list-style-type: none"> y=1 : display option according the x-digit of PC24 y=0 : display option according varied control modes that status shown as followings : <table border="1"> <tr> <td>Control mode position</td> <td>Initial display after power on motor feedback pulse (Note 1)</td> </tr> <tr> <td>position/speed</td> <td>motor feedback pulses(Note 1)/ motor speed</td> </tr> <tr> <td>speed</td> <td>motor speed</td> </tr> <tr> <td>speed/torque</td> <td>motor speed / torque analog command voltage</td> </tr> <tr> <td>torque</td> <td>torque analog command voltage</td> </tr> <tr> <td>torque/position</td> <td>torque analog command voltage / motor feedback pulse (Note 1)</td> </tr> </table> <p>Note 1: the pulse after electronic gear ratio (low word)</p>	0	y	x	Control mode position	Initial display after power on motor feedback pulse (Note 1)	position/speed	motor feedback pulses(Note 1)/ motor speed	speed	motor speed	speed/torque	motor speed / torque analog command voltage	torque	torque analog command voltage	torque/position	torque analog command voltage / motor feedback pulse (Note 1)	Pr.Pt S.T	0000h	0000h ~ 0113h	-
		0	y	x																	
Control mode position	Initial display after power on motor feedback pulse (Note 1)																				
position/speed	motor feedback pulses(Note 1)/ motor speed																				
speed	motor speed																				
speed/torque	motor speed / torque analog command voltage																				
torque	torque analog command voltage																				
torque/position	torque analog command voltage / motor feedback pulse (Note 1)																				
PC25	TL2	Inner torque limit 2 : Setting description is same with PA05. Inner torque limit are decided by the signal state combinations of TL and TL1. Refer to description of PA05.	Pr.Pt S.T	100	0 ~ 100	%															
PC26	VCO	Speed analog command/limit offset : Used to "compensate" the analog offset for a zero command. Speed analog command (VC) is corrected for speed control. Speed analog limit (VLA) is corrected for torque control mode.	S.T	0	-8000 ~ 8000	mV															
PC27	TLO	Torque analog command/limit offset Used to "compensate" the analog offset for a zero command. Torque analog command (TC) is corrected for torque control mode. Torque output analog limit (TLA) is corrected for speed control mode. Refer to section 4.5.5 for more details.	S.T	0	-8000 ~ 8000	mV															
PC28	MO1	Analog monitor ch1 offset Used to set the output offset voltage of analog monitor MON 1. See section 6.6.2 for more details.	Pr.Pt S.T	0	-999 ~ 999	mV															
PC29	MO2	Analog monitor ch2 offset Used to set the output offset voltage of analog monitor MON 2. See section 6.6.2 for more details.	Pr.Pt S.T	0	-999 ~ 999	mV															

PC30	MOG1	Analog monitor ch1 output proportion Used to set output ratio of monitor signal to be viewed. See section 6.6.2 for more details.	Pr.Pt S.T	100	0~100	%				
PC31	MOG2	Analog monitor ch2 output proportion	Pr.Pt S.T	100	0~100	%				
PC32	CMX2	Electronic gear numerator 2 Refer to the description of PA06. See section 6.4.4 for more details.	Pt. Pr	1	1 ~ 2 ²⁶	-				
PC33	CMX3	Electronic gear numerator 3	Pt. Pr	1	1 ~ 2 ²⁶	-				
PC34	CMX4	Electronic gear numerator 4	Pt. Pr	1	1 ~ 2 ²⁶	-				
PC35	VCL (*)	VC input voltage limit Used to limit the range of speed analog command (VC). "0" denotes no limit. A "5000" setting of PC35 as an example : even the actual analog command is 10V, the drive would recognize that the maximum input voltage is only 5V.	S、T	0	0 ~ 20000	mV				
PC36 ~ PC60	Reserved.									
PD01	DIA1 (*)	Digital input signal auto-ON option 1 <table border="1" style="margin-left: 20px;"> <tr> <td>u</td> <td>z</td> <td>y</td> <td>x</td> </tr> </table> <u>x : SON open/short option</u> 0 : controlled by external actual wiring 1 : SON-SG is short-circuit without actual wiring <u>y : LSP open/short option</u> 0 : controlled by external actual wiring 1 : LSP-SG is short-circuit without actual wiring <u>z : LSN open/short option</u> 0 : controlled by external actual wiring 1 : LSN-SG is short-circuit without actual wiring <u>u : EMG open/short option</u> 0 : controlled by external actual wiring 1 : EMG-SG is short-circuit without actual wiring	u	z	y	x	Pr.Pt S.T	0000h	0000h ~ 1111h	-
u	z	y	x							
PD02	DI1 (*)	Digital input 1 option The 12 DI input pins of CN1 are programmable. The preset pin functions are different corresponding to varied control modes. See section 3.3.2 for more details.	Pr.Pt S.T	0001h	0000h ~ 002Fh	-				
PD03	DI2 (*)	Digital input 2 option	Pr.Pt S.T	000Dh	0000h ~ 002Fh	-				
PD04	DI3 (*)	Digital input 3 option	Pr.Pt S.T	0003h	0000h ~ 002Fh	-				
PD05	DI4 (*)	Digital input 4 option	Pr.Pt S.T	0004h	0000h ~ 002Fh	-				
PD06	DI5 (*)	Digital input 5 option	Pr.Pt S.T	0002h	0000h ~ 002Fh	-				
PD07	DI6 (*)	Digital input 6 option	Pr.Pt S.T	000Fh	0000h ~ 002Fh	-				
PD08	DI7 (*)	Digital input 7 option	Pr.Pt S.T	0012h	0000h ~ 002Fh	-				
PD09	DI8 (*)	Digital input 8 option	Pr.Pt S.T	0011h	0000h ~ 002Fh	-				

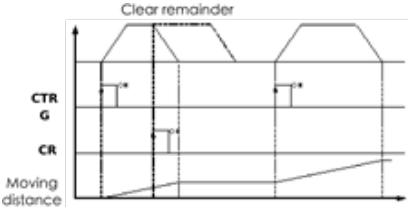
PD10	DO1 (*)	Digital output 1 option The 6 DO output pins of CN1 are programmable. The preset pin functions are different corresponding to varied control modes. See section 3.3.2 for more details	Pr.Pt S.T	0003h	0000h ~ 001Fh	-
PD11	DO2 (*)	Digital output 2 option	Pr.Pt S.T	0008h	0000h ~ 001Fh	-
PD12	DO3 (*)	Digital output 3 option	Pr.Pt S.T	0007h	0000h ~ 001Fh	-
PD13	DO4 (*)	Digital output 4 option	Pr.Pt S.T	0005h	0000h ~ 001Fh	-
PD14	DO5 (*)	Digital output 5 option	Pr.Pt S.T	0001h	0000h ~ 001Fh	-
PD15	DIF (*)	Digital input filter time option 0 0 0 x x : filter time constant 0 : invalid 1 : 2mS 2 : 4mS 3 : 6mS	Pr.Pt S.T	0002h	0000h ~ 0005h	-
PD16	SDI (■)	Digital input on/off state control option 0 0 0 x x : state control option 0 : controlled by external input signals 1 : controlled by communication software	Pr.Pt S.T	0000h	0000h ~ 0FFFh	-
PD17	DOP1 (*)	LSP/LSN triggered stop option 0 0 0 x x : motor stop option 0 : stops immediately 1 : decelerates to stop according to PC02,PC03	Pt. Pr S.	0000h	0000h ~ 0001h	-
PD18	DOP2 (*)	CR signal clear option As CR signal is activated, the deference between position pulses and motor feedback pulses would be cleared. 0 0 0 x x : clear option 0 : CR rising edge trigger 1 : keeps clearing while CR=1 2 : As CR is triggered, the motor would decelerate to stop. The remainder of pulse commands would be neglected. If CTRG signal triggered, the present commands would be executed. Here is the process chart. 	Pt. Pr	0000h	0000h ~ 0001h	-

PD19	DOP3 (*)	Alarm code output option <table border="1" style="margin-left: 20px;"> <tr> <td style="width: 20px; text-align: center;">0</td> <td style="width: 20px; text-align: center;">0</td> <td style="width: 20px; text-align: center;">0</td> <td style="width: 20px; text-align: center;">x</td> </tr> </table> <p style="margin-left: 20px;">x : output option 0 : output definition according to PD10 ~ PD14 1 : to show alarm codes while alarms occurred;see section 10.1 for detail.</p> <table border="1" style="margin-left: 20px;"> <thead> <tr> <th rowspan="2">Setting value x</th> <th colspan="3">Pin Content</th> </tr> <tr> <th>CN1-41</th> <th>CN1-42</th> <th>CN1-45</th> </tr> </thead> <tbody> <tr> <td style="text-align: center;">0</td> <td>By function</td> <td>By function</td> <td>By function</td> </tr> <tr> <td style="text-align: center;">1</td> <td colspan="3">Alarm output when alarm occurs.</td> </tr> </tbody> </table> <p style="margin-left: 20px;">Attention : By function setting is according to the setting value of PD14 to PD10.</p> <table border="1" style="margin-left: 20px;"> <thead> <tr> <th colspan="3">(Note) Alarm code</th> <th rowspan="2">Sign</th> <th rowspan="2">Name</th> </tr> <tr> <th>CN1-41</th> <th>CN1-42</th> <th>CN1-45</th> </tr> </thead> <tbody> <tr> <td rowspan="5" style="text-align: center;">0</td> <td rowspan="5" style="text-align: center;">0</td> <td rowspan="5" style="text-align: center;">0</td> <td>AL. 09</td> <td>Communication abnormal</td> </tr> <tr> <td>AL. 0A</td> <td>Communication time-out</td> </tr> <tr> <td>AL. 0E</td> <td>IGBT overheat</td> </tr> <tr> <td>AL. 0F</td> <td>Memory error</td> </tr> <tr> <td>AL. 10</td> <td>Overload 2</td> </tr> <tr> <td style="text-align: center;">0</td> <td style="text-align: center;">0</td> <td style="text-align: center;">1</td> <td>AL. 02</td> <td>Low voltage</td> </tr> <tr> <td rowspan="2" style="text-align: center;">0</td> <td rowspan="2" style="text-align: center;">1</td> <td rowspan="2" style="text-align: center;">0</td> <td>AL. 01</td> <td>Over voltage</td> </tr> <tr> <td>AL. 04</td> <td>Abnormal regeneration</td> </tr> <tr> <td style="text-align: center;">0</td> <td style="text-align: center;">1</td> <td style="text-align: center;">1</td> <td>AL. 03</td> <td>Over current</td> </tr> <tr> <td style="text-align: center;">1</td> <td style="text-align: center;">0</td> <td style="text-align: center;">0</td> <td>AL. 05</td> <td>Overload</td> </tr> <tr> <td rowspan="3" style="text-align: center;">1</td> <td rowspan="3" style="text-align: center;">0</td> <td rowspan="3" style="text-align: center;">1</td> <td>AL. 06</td> <td>Over speed</td> </tr> <tr> <td>AL. 07</td> <td>Pulse command abnormal</td> </tr> <tr> <td>AL. 08</td> <td>Position error excessive</td> </tr> <tr> <td rowspan="2" style="text-align: center;">1</td> <td rowspan="2" style="text-align: center;">1</td> <td rowspan="2" style="text-align: center;">0</td> <td>AL. 0B</td> <td>Encoder error 1</td> </tr> <tr> <td>AL. 0C</td> <td>Encoder error 2</td> </tr> <tr> <td style="text-align: center;">1</td> <td style="text-align: center;">1</td> <td style="text-align: center;">1</td> <td>AL. 11</td> <td>Motor mismatched</td> </tr> </tbody> </table> <p style="margin-left: 20px;">Note 0 : OFF, 1 : ON</p>	0	0	0	x	Setting value x	Pin Content			CN1-41	CN1-42	CN1-45	0	By function	By function	By function	1	Alarm output when alarm occurs.			(Note) Alarm code			Sign	Name	CN1-41	CN1-42	CN1-45	0	0	0	AL. 09	Communication abnormal	AL. 0A	Communication time-out	AL. 0E	IGBT overheat	AL. 0F	Memory error	AL. 10	Overload 2	0	0	1	AL. 02	Low voltage	0	1	0	AL. 01	Over voltage	AL. 04	Abnormal regeneration	0	1	1	AL. 03	Over current	1	0	0	AL. 05	Overload	1	0	1	AL. 06	Over speed	AL. 07	Pulse command abnormal	AL. 08	Position error excessive	1	1	0	AL. 0B	Encoder error 1	AL. 0C	Encoder error 2	1	1	1	AL. 11	Motor mismatched	Pr.Pt S.T	0000h	0000h ~ 0001h	-
		0	0	0	x																																																																																				
Setting value x	Pin Content																																																																																								
	CN1-41	CN1-42	CN1-45																																																																																						
0	By function	By function	By function																																																																																						
1	Alarm output when alarm occurs.																																																																																								
(Note) Alarm code			Sign	Name																																																																																					
CN1-41	CN1-42	CN1-45																																																																																							
0	0	0	AL. 09	Communication abnormal																																																																																					
			AL. 0A	Communication time-out																																																																																					
			AL. 0E	IGBT overheat																																																																																					
			AL. 0F	Memory error																																																																																					
			AL. 10	Overload 2																																																																																					
0	0	1	AL. 02	Low voltage																																																																																					
0	1	0	AL. 01	Over voltage																																																																																					
			AL. 04	Abnormal regeneration																																																																																					
0	1	1	AL. 03	Over current																																																																																					
1	0	0	AL. 05	Overload																																																																																					
1	0	1	AL. 06	Over speed																																																																																					
			AL. 07	Pulse command abnormal																																																																																					
			AL. 08	Position error excessive																																																																																					
1	1	0	AL. 0B	Encoder error 1																																																																																					
			AL. 0C	Encoder error 2																																																																																					
1	1	1	AL. 11	Motor mismatched																																																																																					
Alarm reset triggered process <table border="1" style="margin-left: 20px;"> <tr> <td style="width: 20px; text-align: center;">0</td> <td style="width: 20px; text-align: center;">0</td> <td style="width: 20px; text-align: center;">0</td> <td style="width: 20px; text-align: center;">x</td> </tr> </table> <p style="margin-left: 20px;">x : clear option 0 : PWM signal off(If the motor is running, it would coast to stop. If the motor is shaft-lock, it would become rotatable.) 1:invalid</p>	0	0	0	x																																																																																					
0	0	0	x																																																																																						
PD21	DI9 (*)	Digital input 9 option The 12 DI input pins of CN1 are programmable. The preset pin functions are different corresponding to varied control modes. See section 3.3.2 for more details.	Pr.Pt S.T	0018h	0000h ~ 002Fh	-																																																																																			
PD22	DI10 (*)	Digital input 10 option	Pr.Pt S.T	0019h	0000h ~ 002Fh	-																																																																																			
PD23	DI11 (*)	Digital input 11 option	Pr.Pt S.T	0005h	0000h ~ 002Fh	-																																																																																			
PD24	DI12 (*)	Digital input 12 option	Pr.Pt S.T	0010h	0000h ~ 002Fh	-																																																																																			

PD25	ITST (■)	<p>Digital input status</p> <p>Digital input contacts (total of 12 points) are determined by the setting methods of digital. The digital input status of PD25 that bit 0 ~ 11 corresponds to DI1~DI12 at the time of communication control. Bit binary representation 0: digital input contacts OFF 1: digital input contacts ON</p> <p>The DI input signal can come from external terminal (DI1 ~ DI12) or software PD25 (Bit 0 ~ 11 of corresponding parameter PD25) and is determined by PD16. If the PD16 corresponding bit is 1, then the source is software DI (PD25). Otherwise, from hardware DI.</p> <p>Read PD25 value as 0x0011 means DI1 ~ DI5 is ON at the end.</p> <p>Write PD25 value as 0x0011 means DI1 ~ DI5 is ON while communication, but doesn't mean the final digital input of DI1 and DI5 is ON. It is determined by PD16.</p> <p>Digital input The function planning of DI (DI1~DI8) please refer to PD02~PD09、DI9~DI12 please refer to PD21~PD24. Example 1 : When PD16 is 0FFFh and PD25 is 0000h, the status of DI1~DI12 is all controlled by communication contact. When DI1~DI12 is all OFF, all external hardware terminals DI1~DI12 and SG break over, digital input signals will not be affected, all controlled by communications contacts, all digital input contacts DI1~DI12 still OFF. Example 2 : External hardware terminal DI12~DI1 represented by bit11~bit0. Bit binary for description :bit11~bit0 represent DI12~DI1 (left to right) Digital input contact source switch (PD16): 111111000000 External hardware terminal status: 111100001111 (1 represent ON, 0 represent OFF) Communication control digital input contact status (PD25): 111000111000</p>	Pr.Pt S.T	0000h	0000h ~ 0FFFh	-
PD26	DO6 (*)	<p>Digital output 6 option</p> <p>The 6 DO output pins of CN1 are programmable. The preset pin functions are different corresponding to varied control modes. See section 3.3.2 for more details.</p>	Pr.Pt S.T	0002h	0000h ~ 001Fh	-
PD27	DOD (*)	<p>Output signal contacts definitions</p> <p>Output signal contact of the DO1~DO6 definition The parameter value bit0~bit5 representing the DO1~DO6 pin definition defines the output contact for a or b contact 0 : normal open contact A 1 : normal close contact B</p> <p>Digital output logic option To defined logic of DO1~ DO6. The bit0~ bit5 corresponds to DI1~ DI6. Contact A or contact B is selectable. 0 : normal open contact A 1 : normal close contact B</p>	Pr.Pt S.T	0020h	0000h ~ 003F	-

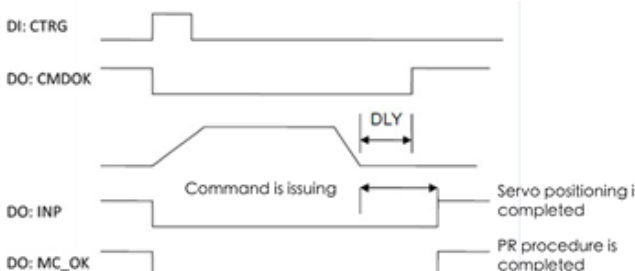
PD28	MCOK	<p>Motion reached (DO : MC_OK) operation options</p> <table border="1" style="margin-left: 20px;"> <tr> <td style="width: 20px; text-align: center;">0</td> <td style="width: 20px; text-align: center;">0</td> <td style="width: 20px; text-align: center;">y</td> <td style="width: 20px; text-align: center;">x</td> </tr> </table> <p style="margin-left: 20px;"> x=0 : Output not remain , x=1 : output remain y=0 : Position offset warning AL.1B disable y=1 : Position offset warning AL.1B enable </p>  <ol style="list-style-type: none"> Command trigger : Pr new command begins valid, command 3 begins to output and clear signals of 2, 4, 5, 6. CMD_OK : To check if command 3 finished the output and enable to set delay time DLY. Command output : Output position command pattern according to the setting value of acceleration and deceleration speed. INP : Check if position error is in the setting range of parameter PA12. MC_OK : Indicates that the command output is complete and the servo position is complete too, and signal 2, 4 is AND MC_OK(output remain) : Same with 5, but once the output is ON (7) maintained, no matter the signal 4 is OFF. Users can only choose one output for signal 5 or signal 6, designated by the parameter PD28.X. Position offset : When 7 occurs, if 4(or 5) becomes too OFF means position offset which would trigger AL.1B. The alert can be set from parameter PD28.Y. 	0	0	y	x	Pr	0000h	0000h ~ 0011h	-
0	0	y	x							
PD29 ~ PD40	Reserved									

No	Abbr.	Function description	Control Mode	Initial Value	Setting range	unit														
PE01	PDEF1	Home return definition Detail parameter definition as followings:	Pr	00000000h	00000000h ~ 10FFFF3Fh	-														
		<table border="1"> <thead> <tr> <th>31~28</th> <th>27~24</th> <th>23~20</th> <th>19~16</th> <th>15~12</th> <th>11~8</th> <th>7~0 bit</th> </tr> </thead> <tbody> <tr> <td>BOOT</td> <td>-</td> <td>DLY</td> <td>-</td> <td>DEC1</td> <td>ACC</td> <td>PATH</td> </tr> </tbody> </table> <ul style="list-style-type: none"> • PATH: path type (bit0~bit7) 0: Stop: Finish home returning and stop. 1~63: Auto: Finish home returning and operate next path. • ACC: acceleration time selection 0~F which are corresponding to PF49~PF64. • DEC1: Section 1 of home return deceleration time selection, DEC setting value is 0~F, corresponds to PF49~PF64. <p>DLY: Delay time selection 0~F , corresponds to PF65~PF80□</p> <ul style="list-style-type: none"> • BOOT: When drive power on, check if home point search operates or not : 0 : Do not home return. 1 : Do home return automatically.(the first SRV ON after power on.) • In addition to the above definitions, the related settings about home returning: 1. PA04 home return mode. 2. PA08~PA09 the setting speed of searching home. 3. PE02 : ORG_DEF the coordinate value of home could be 0 or not. This function is for traverse moving of the coordinate system. <p>A. Goes back to the origin after home returning function of PA04 in SDA series, does not provide in SDH, but through a different method. Find the origin (Sensor or Z), the drive must decelerate to stop and stop position will be a short distance beyond the origin: If it does not pull back to the origin, PATH=0. If it pulls back to the origin, the PATH= non-zero, and users can set the path to PABS=ORG_DEF.</p> <p>B . After finding the origin (Sensor or Z), move some offsets of S, and define the moved coordinates as P: PATH= non-zero, and set the ORG_DEF=P-S, the path is absolute position, command =P.</p>	31~28	27~24	23~20	19~16	15~12	11~8	7~0 bit	BOOT	-	DLY	-	DEC1	ACC	PATH				
31~28	27~24	23~20	19~16	15~12	11~8	7~0 bit														
BOOT	-	DLY	-	DEC1	ACC	PATH														

No	Abbr.	Function description	Control Mode	Initial Value	Setting range	unit																																																								
PE02	PDEF1	Origin definition	Control mode	Initial value	Range	Unit																																																								
		<table border="1"> <tr> <td>31~16</td> <td>15~0 bit</td> </tr> <tr> <td colspan="2">ORG_DEF(32bit)</td> </tr> </table>	31~16	15~0 bit	ORG_DEF(32bit)		Pr	0	$(-2^{31}+1)$ ~ $(2^{31}-1)$	-																																																				
31~16	15~0 bit																																																													
ORG_DEF(32bit)																																																														
PE03	PDEF1	PATH#1 definition Detail definition as following. See the chapter 7 for details of PR mode.	Pr	00000000h	00000000h ~ FFFFFFFFh	-																																																								
		<table border="1"> <tr> <td></td> <td>31~28</td> <td>27~24</td> <td>23~20</td> <td>19~16</td> <td>15~12</td> <td>11~8</td> <td>7~4</td> <td>3~0 bit</td> </tr> <tr> <td>PE03</td> <td>-</td> <td>-</td> <td>DLY</td> <td>-</td> <td>-</td> <td>-</td> <td>OPT</td> <td>TYPE</td> </tr> <tr> <td>PE04</td> <td colspan="8">DATA(32bit)</td> </tr> </table> <ul style="list-style-type: none"> TYPE、OPT <table border="1"> <tr> <td colspan="4">OPT option</td> <td>TYPE path model</td> </tr> <tr> <td>7</td> <td>6</td> <td>5</td> <td>4 BIT</td> <td>3~0 BIT</td> </tr> <tr> <td>-</td> <td>UNIT</td> <td>AUTO</td> <td>INS</td> <td>1: SPEED Control</td> </tr> <tr> <td colspan="2">CMD</td> <td>OVLP</td> <td>INS</td> <td>2: SINGLE position control, stop after finish.</td> </tr> <tr> <td>-</td> <td>-</td> <td>-</td> <td>INS</td> <td>3: AUTO position control, load to next path after finish.</td> </tr> <tr> <td>-</td> <td>-</td> <td>-</td> <td>INS</td> <td>7: JUMP Jump to assigned path.</td> </tr> <tr> <td>-</td> <td>-</td> <td>AUTO</td> <td>INS</td> <td>8: Write assigned parameter to path.</td> </tr> </table> <ul style="list-style-type: none"> TYPE : 1 ~ 3 DO : STP and soft limit is acceptable. INS : When this path runs, interrupt the previous path. OVLP : Allows the next path overlap. Overlap is invalid in speed mode. When position mode overlap, DLY is inactive. AUTO : Load to next path after PR program finish. CMD : See the command description of chapter 7. DLY : 0 ~ F, the delay time number(4 BIT). The delay after this path finished, delay output code, external INS is invalid (DLY related parameter :PF65~PF80) 		31~28	27~24	23~20	19~16	15~12	11~8	7~4	3~0 bit	PE03	-	-	DLY	-	-	-	OPT	TYPE	PE04	DATA(32bit)								OPT option				TYPE path model	7	6	5	4 BIT	3~0 BIT	-	UNIT	AUTO	INS	1: SPEED Control	CMD		OVLP	INS	2: SINGLE position control, stop after finish.	-	-	-	INS	3: AUTO position control, load to next path after finish.	-	-	-	INS	7: JUMP Jump to assigned path.	-	-	AUTO
	31~28	27~24	23~20	19~16	15~12	11~8	7~4	3~0 bit																																																						
PE03	-	-	DLY	-	-	-	OPT	TYPE																																																						
PE04	DATA(32bit)																																																													
OPT option				TYPE path model																																																										
7	6	5	4 BIT	3~0 BIT																																																										
-	UNIT	AUTO	INS	1: SPEED Control																																																										
CMD		OVLP	INS	2: SINGLE position control, stop after finish.																																																										
-	-	-	INS	3: AUTO position control, load to next path after finish.																																																										
-	-	-	INS	7: JUMP Jump to assigned path.																																																										
-	-	AUTO	INS	8: Write assigned parameter to path.																																																										
No	Abbr.	Function description	Control Mode	Initial Value	Setting range	unit																																																								
PE04	PDAT1	PATH#1 data PE03 defines attributes of the target point, PE04 corresponding PE03 target point or jumping PATH_NO Note :PATH : Program	Pr	0	For non index position function $(-2^{31}) \sim (2^{31}-1)$ For index position function (0~4194304)	-																																																								
PE05	PDEF2	PATH#2 definition Please refer to the description of PE03.	Pr	00000000h	00000000h~FFFFFFFFh	-																																																								
PE06	PDAT2	PATH#2 data Please refer to the description of PE04.	Pr	0	$(-2^{31}+1) \sim (2^{31}-1)$	-																																																								
PE07	PDEF3	PATH#3 definition Please refer to the description of PE03.	Pr	00000000h	00000000h~FFFFFFFFh	-																																																								
PE08	PDAT3	PATH#3 data Please refer to the description of PE04.	Pr	0	$(-2^{31}+1) \sim (2^{31}-1)$	-																																																								
PE09	PDEF4	PATH#4 definition Please refer to the description of PE03.	Pr	00000000h	00000000h~FFFFFFFFh	-																																																								
PE10	PDAT4	PATH#4 data Please refer to the description of PE04.	Pr	0	$(-2^{31}+1) \sim (2^{31}-1)$	-																																																								
PE11	PDEF5	PATH#5 definition Please refer to the description of PE03.	Pr	00000000h	00000000h~FFFFFFFFh	-																																																								
PE12	PDAT5	PATH#5 data Please refer to the description of PE04.	Pr	0	$(-2^{31}+1) \sim (2^{31}-1)$	-																																																								
PE13	PDEF6	PATH#6 definition Please refer to the description of PE03.	Pr	00000000h	00000000h~FFFFFFFFh	-																																																								
PE14	PDAT6	PATH#6 data Please refer to the description of PE06.		0	$(-2^{31}+1) \sim (2^{31}-1)$	-																																																								
PE15	PDEF7	PATH#7 definition Please refer to the description of PE03.	Pr	00000000h	00000000h~FFFFFFFFh	-																																																								
PE16	PDAT7	PATH#7 data Please refer to the description of PE04.	Pr	0	$(-2^{31}+1) \sim (2^{31}-1)$	-																																																								

PE18	PDAT8	PATH#8 data Please refer to the description of PE04.	Pr	0	$(-2^{31}+1) \sim (2^{31}-1)$	-
PE19	PDEF9	PATH#9 definition Please refer to the description of PE03.	Pr	00000000h	00000000h~FFFFFFFFh	-
PE20	PDAT9	PATH#9 data Please refer to the description of PE04.	Pr	0	$(-2^{31}+1) \sim (2^{31}-1)$	-
PE21	PDEF10	PATH#10 definition Please refer to the description of PE03.	Pr	00000000h	00000000h~FFFFFFFFh	-
PE22	PDAT10	PATH#10 data Please refer to the description of PE04.	Pr	0	$(-2^{31}+1) \sim (2^{31}-1)$	-
PE23	PDEF11	PATH#11 definition Please refer to the description of PE03.	Pr	00000000h	00000000h~FFFFFFFFh	-
PE24	PDAT11	PATH#11 data Please refer to the description of PE04.	Pr	0	$(-2^{31}+1) \sim (2^{31}-1)$	-
PE25	PDEF12	PATH#12 definition Please refer to the description of PE03.	Pr	00000000h	00000000h~FFFFFFFFh	-
PE18	PDAT8	PATH#8 data Please refer to the description of PE04.	Pr	0	$(-2^{31}+1) \sim (2^{31}-1)$	-
PE17	PDEF8	PATH#8 definition Please refer to the description of PE03.	Pr	00000000h	00000000h~FFFFFFFFh	-
PE19	PDEF9	PATH#9 definition Please refer to the description of PE03.	Pr	00000000h	00000000h~FFFFFFFFh	-
PE20	PDAT9	PATH#9 data Please refer to the description of PE04.	Pr	0	$(-2^{31}+1) \sim (2^{31}-1)$	-
PE21	PDEF10	PATH#10 definition Please refer to the description of PE03.	Pr	00000000h	00000000h~FFFFFFFFh	-
PE22	PDAT10	PATH#10 data Please refer to the description of PE04.	Pr	0	$(-2^{31}+1) \sim (2^{31}-1)$	-
PE23	PDEF11	PATH#11 definition Please refer to the description of PE03.	Pr	00000000h	00000000h~FFFFFFFFh	-
PE24	PDAT11	PATH#11 data Please refer to the description of PE04.	Pr	0	$(-2^{31}+1) \sim (2^{31}-1)$	-
PE25	PDEF12	PATH#12 definition Please refer to the description of PE03.	Pr	00000000h	00000000h~FFFFFFFFh	-
PE26	PDAT12	PATH#12 data Please refer to the description of PE04.	Pr	0	$(-2^{31}+1) \sim (2^{31}-1)$	-
PE27	PDEF13	PATH#13 definition Please refer to the description of PE03.	Pr	00000000h	00000000h~FFFFFFFFh	-
PE28	PDAT13	PATH#13 data Please refer to the description of PE04.	Pr	0	$(-2^{31}+1) \sim (2^{31}-1)$	-
PE29	PDEF14	PATH#14 definition Please refer to the description of PE03.	Pr	00000000h	00000000h~FFFFFFFFh	-
PE30	PDAT14	PATH#14 data Please refer to the description of PE04.	Pr	0	$(-2^{31}+1) \sim (2^{31}-1)$	-
PE31	PDEF15	PATH#15 definition Please refer to the description of PE03.	Pr	00000000h	00000000h~FFFFFFFFh	-
PE32	PDAT15	PATH#15 data Please refer to the description of PE04.	Pr	0	$(-2^{31}+1) \sim (2^{31}-1)$	-
PE33	PDEF16	PATH#16 definition Please refer to the description of PE03.	Pr	00000000h	00000000h~FFFFFFFFh	-
PE34	PDAT16	PATH#16 data Please refer to the description of PE04.	Pr	0	$(-2^{31}+1) \sim (2^{31}-1)$	-
PE35	PDEF17	PATH#17 definition Please refer to the description of PE03.	Pr	00000000h	00000000h~FFFFFFFFh	-
PE36	PDAT17	PATH#17 data Please refer to the description of PE04.	Pr	0	$(-2^{31}+1) \sim (2^{31}-1)$	-
PE37	PDEF18	PATH#18 definition Please refer to the description of PE03.	Pr	00000000h	00000000h~FFFFFFFFh	-
PE38	PDAT18	PATH#18 data Please refer to the description of PE04.	Pr	0	$(-2^{31}+1) \sim (2^{31}-1)$	-
PE39	PDEF19	PATH#19 definition Please refer to the description of PE03.	Pr	00000000h	00000000h~FFFFFFFFh	-

PE40	PDAT19	PATH#19 data Please refer to the description of PE04.	Pr	0	$(-2^{31}+1) \sim (2^{31}-1)$	-
PE41	PDEF20	PATH#20 definition Please refer to the description of PE03.	Pr	00000000h	00000000h~FFFFFFFFh	-
PE42	PDAT20	PATH#20 data Please refer to the description of PE04.	Pr	0	$(-2^{31}+1) \sim (2^{31}-1)$	-
PE43	PDEF21	PATH#21 definition Please refer to the description of PE03.	Pr	00000000h	00000000h~FFFFFFFFh	-
PE44	PDAT21	PATH#21 data Please refer to the description of PE04.	Pr	0	$(-2^{31}+1) \sim (2^{31}-1)$	-
PE45	PDEF22	PATH#22 definition Please refer to the description of PE03.	Pr	00000000h	00000000h~FFFFFFFFh	-
PE46	PDAT22	PATH#22 data Please refer to the description of PE04.	Pr	0	$(-2^{31}+1) \sim (2^{31}-1)$	-
PE47	PDEF23	PATH#23 definition Please refer to the description of PE03.	Pr	00000000h	00000000h~FFFFFFFFh	-
PE48	PDAT23	PATH#23 data Please refer to the description of PE04.	Pr	0	$(-2^{31}+1) \sim (2^{31}-1)$	-
PE49	PDEF24	PATH#24 definition Please refer to the description of PE03.	Pr	00000000h	00000000h~FFFFFFFFh	-
PE50	PDAT24	PATH#24 data Please refer to the description of PE04.	Pr	0	$(-2^{31}+1) \sim (2^{31}-1)$	-
PE51	PDEF25	PATH#25 definition Please refer to the description of PE03.	Pr	00000000h	00000000h~FFFFFFFFh	-
PE52	PDAT25	PATH#25 data Please refer to the description of PE04.	Pr	0	$(-2^{31}+1) \sim (2^{31}-1)$	-
PE53	PDEF26	PATH#26 definition Please refer to the description of PE03.	Pr	00000000h	00000000h~FFFFFFFFh	-
PE54	PDAT26	PATH#26 data Please refer to the description of PE04.	Pr	0	$(-2^{31}+1) \sim (2^{31}-1)$	-
PE55	PDEF27	PATH#27 definition Please refer to the description of PE03.	Pr	00000000h	00000000h~FFFFFFFFh	-
PE56	PDAT27	PATH#27 data Please refer to the description of PE04.	Pr	0	$(-2^{31}+1) \sim (2^{31}-1)$	-
PE57	PDEF28	PATH#28 definition Please refer to the description of PE03.	Pr	00000000h	00000000h~FFFFFFFFh	-
PE58	PDAT28	PATH#28 data Please refer to the description of PE04.	Pr	0	$(-2^{31}+1) \sim (2^{31}-1)$	-
PE59	PDEF29	PATH#29 definition Please refer to the description of PE03.	Pr	00000000h	00000000h~FFFFFFFFh	-
PE60	PDAT29	PATH#29 data Please refer to the description of PE04.	Pr	0	$(-2^{31}+1) \sim (2^{31}-1)$	-
PE61	PDEF30	PATH#30 definition Please refer to the description of PE03.	Pr	00000000h	00000000h~FFFFFFFFh	-
PE62	PDAT30	PATH#30 data Please refer to the description of PE04.	Pr	0	$(-2^{31}+1) \sim (2^{31}-1)$	-
PE64	PDAT31	PATH#31 data Please refer to the description of PE04.	Pr	0	$(-2^{31}+1) \sim (2^{31}-1)$	-
PE65	PDEF32	PATH#32 definition Please refer to the description of PE03.	Pr	00000000h	00000000h~FFFFFFFFh	-
PE66	PDAT32	PATH#32 data Please refer to the description of PE04.	Pr	0	$(-2^{31}+1) \sim (2^{31}-1)$	-
PE63	PDEF31	PATH#31 definition Please refer to the description of PE03.	Pr	00000000h	00000000h~FFFFFFFFh	-
PE67	PDEF33	PATH#33 definition Please refer to the description of PE03.	Pr	00000000h	00000000h~FFFFFFFFh	-
PE68	PDAT33	PATH#33 data Please refer to the description of PE04.	Pr	0	$(-2^{31}+1) \sim (2^{31}-1)$	-
PE69	PDEF34	PATH#34 definition Please refer to the description of PE03.	Pr	00000000h	00000000h~FFFFFFFFh	-
PE70	PDAT34	PATH#34 data Please refer to the description of PE04.	Pr	0	$(-2^{31}+1) \sim (2^{31}-1)$	-

PE71	PDEF35	PATH#35 definition Please refer to the description of PE03.	Pr	00000000h	00000000h~FFFFFFFFh	-
PE72	PDAT35	PATH#35 data Please refer to the description of PE04.	Pr	0	$(-2^{31}+1) \sim (2^{31}-1)$	-
PE73	PDEF36	PATH#36 definition Please refer to the description of PE03.	Pr	00000000h	00000000h~FFFFFFFFh	-
PE74	PDAT36	PATH#36 data Please refer to the description of PE04.	Pr	0	$(-2^{31}+1) \sim (2^{31}-1)$	-
PE75	PDEF37	PATH#37 definition Please refer to the description of PE03.	Pr	00000000h	00000000h~FFFFFFFFh	-
PE76	PDAT37	PATH#37 data Please refer to the description of PE04.	Pr	0	$(-2^{31}+1) \sim (2^{31}-1)$	-
PE77	PDEF38	PATH#38 definition Please refer to the description of PE03.	Pr	00000000h	00000000h~FFFFFFFFh	-
PE78	PDAT38	PATH#38 data Please refer to the description of PE04.	Pr	0	$(-2^{31}+1) \sim (2^{31}-1)$	-
PE79	PDEF39	PATH#39 definition Please refer to the description of PE03.	Pr	00000000h	00000000h~FFFFFFFFh	-
PE80	PDAT39	PATH#39 data Please refer to the description of PE04.	Pr	0	$(-2^{31}+1) \sim (2^{31}-1)$	-
PE81	PDEF40	PATH#40 definition Please refer to the description of PE03.	Pr	00000000h	00000000h~FFFFFFFFh	-
PE82	PDAT40	PATH#40 data Please refer to the description of PE04.	Pr	0	$(-2^{31}+1) \sim (2^{31}-1)$	-
PE83	PDEF41	PATH#41 definition Please refer to the description of PE03.	Pr	00000000h	00000000h~FFFFFFFFh	-
PE84	PDAT41	PATH#41 data Please refer to the description of PE04.	Pr	0	$(-2^{31}+1) \sim (2^{31}-1)$	-
PE85	PDEF42	PATH#42 definition Please refer to the description of PE03.	Pr	00000000h	00000000h~FFFFFFFFh	-
PE86	PDAT42	PATH#42 data Please refer to the description of PE04.	Pr	0	$(-2^{31}+1) \sim (2^{31}-1)$	-
PE87	PDEF43	PATH#43 definition Please refer to the description of PE03.	Pr	00000000h	00000000h~FFFFFFFFh	-
PE88	PDAT43	PATH#43 data Please refer to the description of PE04.	Pr	0	$(-2^{31}+1) \sim (2^{31}-1)$	-
PE89	PDEF44	PATH#44 definition Please refer to the description of PE03.	Pr	00000000h	00000000h~FFFFFFFFh	-
PE90	PDAT44	PATH#44 data Please refer to the description of PE04.	Pr	0	$(-2^{31}+1) \sim (2^{31}-1)$	-
PE91	PDEF45	PATH#45 definition Please refer to the description of PE03.	Pr	00000000h	00000000h~FFFFFFFFh	-
PE92	PDAT45	PATH#45 data Please refer to the description of PE04.	Pr	0	$(-2^{31}+1) \sim (2^{31}-1)$	-
PE93	PDEF46	PATH#46 definition Please refer to the description of PE03.	Pr	00000000h	00000000h~FFFFFFFFh	-
PE94	PDAT46	PATH#46 data Please refer to the description of PE04.	Pr	0	$(-2^{31}+1) \sim (2^{31}-1)$	-
PE95	PDEF47	PATH#47 definition Please refer to the description of PE03.	Pr	00000000h	00000000h~FFFFFFFFh	-
PE96	PDAT47	PATH#47 data Please refer to the description of PE04.	Pr	0	$(-2^{31}+1) \sim (2^{31}-1)$	-
PE97	PDEF48	PATH#48 definition Please refer to the description of PE03.	Pr	00000000h	00000000h~FFFFFFFFh	-
PE98	PDAT48	PATH#48 data Please refer to the description of PE04.	Pr	0	$(-2^{31}+1) \sim (2^{31}-1)$	-
PE99	Reserved.					

No	Abbr.	Function description	Control Mode	Initial Value	Setting range	unit
PF01	PDEF49	PATH#49 definition Please refer to the description of PE03.	Pr	00000000h	00000000h~FFFFFFFFh	-
PF02	PDAT49	PATH#49 data Please refer to the description of PE04.	Pr	0	$(-2^{31}+1) \sim (2^{31}-1)$	-
PF03	PDEF50	PATH#50 definition Please refer to the description of PE03.	Pr	00000000h	00000000h~FFFFFFFFh	-
PF04	PDAT50	PATH#50 data Please refer to the description of PE04.	Pr	0	$(-2^{31}+1) \sim (2^{31}-1)$	-
PF05	PDEF51	PATH#51 definition Please refer to the description of PE03.	Pr	00000000h	00000000h~FFFFFFFFh	-
PF06	PDAT51	PATH#51 data Please refer to the description of PE04.	Pr	0	$(-2^{31}+1) \sim (2^{31}-1)$	-
PF07	PDEF52	PATH#52 definition Please refer to the description of PE03.	Pr	00000000h	00000000h~FFFFFFFFh	-
PF08	PDAT52	PATH#52 data Please refer to the description of PE04.	Pr	0	$(-2^{31}+1) \sim (2^{31}-1)$	-
PF09	PDEF53	PATH#53 definition Please refer to the description of PE03.	Pr	00000000h	00000000h~FFFFFFFFh	-
PF10	PDAT53	PATH#53 data Please refer to the description of PE04.	Pr	0	$(-2^{31}+1) \sim (2^{31}-1)$	-
PF11	PDEF54	PATH#54 definition Please refer to the description of PE03.	Pr	00000000h	00000000h~FFFFFFFFh	-
PF12	PDAT54	PATH#54 data Please refer to the description of PE04.	Pr	0	$(-2^{31}+1) \sim (2^{31}-1)$	-
PF13	PDEF55	PATH#55 definition Please refer to the description of PE03.	Pr	00000000h	00000000h~FFFFFFFFh	-
PF14	PDAT55	PATH#55 data Please refer to the description of PE04.	Pr	0	$(-2^{31}+1) \sim (2^{31}-1)$	-
PF15	PDEF56	PATH#56 definition Please refer to the description of PE03.	Pr	00000000h	00000000h~FFFFFFFFh	-
PF16	PDAT56	PATH#56 data Please refer to the description of PE04.	Pr	0	$(-2^{31}+1) \sim (2^{31}-1)$	-
PF17	PDEF57	PATH#57 definition Please refer to the description of PE03.	Pr	00000000h	00000000h~FFFFFFFFh	-
PF18	PDAT57	PATH#57 data Please refer to the description of PE04.	Pr	0	$(-2^{31}+1) \sim (2^{31}-1)$	-
PF19	PDEF58	PATH#58 definition Please refer to the description of PE03.	Pr	00000000h	00000000h~FFFFFFFFh	-
PF20	PDAT58	PATH#58 data Please refer to the description of PE04.	Pr	0	$(-2^{31}+1) \sim (2^{31}-1)$	-
PF21	PDEF59	PATH#59 definition Please refer to the description of PE03.	Pr	00000000h	00000000h~FFFFFFFFh	-
PF22	PDAT59	PATH#59 data Please refer to the description of PE04.	Pr	0	$(-2^{31}+1) \sim (2^{31}-1)$	-
PF23	PDEF60	PATH#60 definition Please refer to the description of PE03.	Pr	00000000h	00000000h~FFFFFFFFh	-
PF24	PDAT60	PATH#60 data Please refer to the description of PE04.	Pr	0	$(-2^{31}+1) \sim (2^{31}-1)$	-
PF25	PDEF61	PATH#61 definition Please refer to the description of PE03.	Pr	00000000h	00000000h~FFFFFFFFh	-
PF26	PDAT61	PATH#61 data Please refer to the description of PE04.	Pr	0	$(-2^{31}+1) \sim (2^{31}-1)$	-
PF27	PDEF62	PATH#62 definition Please refer to the description of PE03.	Pr	00000000h	00000000h~FFFFFFFFh	-
PF28	PDAT62	PATH#62 data Please refer to the description of PE04.	Pr	0	$(-2^{31}+1) \sim (2^{31}-1)$	-
PF29	PDEF63	PATH#63 definition Please refer to the description of PE03.	Pr	00000000h	00000000h~FFFFFFFFh	-
PF30	PDAT63	PATH#63 data Please refer to the description of PE04.	Pr	0	$(-2^{31}+1) \sim (2^{31}-1)$	-
PF31	Reserved.					

PF32	Reserved.					
PF33	POV1	Speed setting of inner position command 1	Pr	50	1~6000	rpm
PF34	POV2	Speed setting of inner position command 2	Pr	10	1~6000	rpm
PF35	POV3	Speed setting of inner position command 3	Pr	200	1~6000	rpm
PF36	POV4	Speed setting of inner position command 4	Pr	300	1~6000	rpm
PF37	POV5	Speed setting of inner position command 5	Pr	500	1~6000	rpm
PF38	POV6	Speed setting of inner position command 6	Pr	800	1~6000	rpm
PF39	POV7	Speed setting of inner position command 7	Pr	1000	1~6000	rpm
PF40	POV8	Speed setting of inner position command 8	Pr	1200	1~6000	rpm
PF41	POV9	Speed setting of inner position command 9	Pr	1500	1~6000	rpm
PF42	POV10	Speed setting of inner position command 10	Pr	1800	1~6000	rpm
PF43	POV11	Speed setting of inner position command 11	Pr	2000	1~6000	rpm
PF44	POV12	Speed setting of inner position command 12	Pr	2200	1~6000	rpm
PF45	POV13	Speed setting of inner position command 13	Pr	2400	1~6000	rpm
PF46	POV14	Speed setting of inner position command 14	Pr	2700	1~6000	rpm
PF47	POV15	Speed setting of inner position command 15	Pr	3000	1~6000	rpm
PF48	POV16	Speed setting of inner position command 16	Pr	3000	1~6000	rpm
PF49	POA1	Acceleration/deceleration time of inner position command 1 Acceleration/deceleration time setting of Pr mode, which means the time spent from speed 0 to rated speed.	Pr	200	1~65550	ms
PF50	POA2	Acceleration/deceleration time of inner position command 2 Please refer to PF49.	Pr	200	1~65550	ms
PF51	POA3	Acceleration/deceleration time of inner position command 3 Please refer to PF49.	Pr	300	1~65550	ms
PF52	POA4	Acceleration/deceleration time of inner position command 4 Please refer to PF49.	Pr	500	1~65550	ms
PF53	POV5	Acceleration/deceleration time of inner position command 5 Please refer to PF49.	Pr	600	1~65550	ms
PF54	POV6	Acceleration/deceleration time of inner position command 6 Please refer to PF49.	Pr	800	1~65550	ms
PF55	POV7	Acceleration/deceleration time of inner position command 7 Please refer to PF49.	Pr	900	1~65550	ms
PF56	POV8	Acceleration/deceleration time of inner position command 8 Please refer to PF49.	Pr	1000	1~65550	ms
PF57	POV9	Acceleration/deceleration time of inner position command 9 Please refer to PF49.	Pr	1200	1~65550	ms
PF58	POV10	Acceleration/deceleration time of inner position command 10 Please refer to PF49.	Pr	1400	1~65550	ms
PF59	POV11	Acceleration/deceleration time of inner position command 11 Please refer to PF49.	Pr	1600	1~65550	ms
PF60	POV12	Acceleration/deceleration time of inner position command 12 Please refer to PF49.	Pr	2000	1~65550	ms
PF61	POV13	Acceleration/deceleration time of inner position command 13 Please refer to PF49.	Pr	2500	1~65550	ms
PF62	POV14	Acceleration/deceleration time of inner position command 14 Please refer to PF49.	Pr	3000	1~65550	ms
PF63	POV15	Acceleration/deceleration time of inner position command 15 Please refer to PF49.	Pr	4000	1~65550	ms

PF64	POV16	Acceleration/deceleration time of inner position command 16 Please refer to PF49.	Pr	5000	1~65550	ms																										
PF65	DLY1	Delay time of reached position 1 Delay time setting of Pr mode	Pr	0	0~32767	ms																										
PF66	DLY2	Delay time of reached position 2 Please refer to PF65.	Pr	100	0~32767	ms																										
PF67	DLY3	Delay time of reached position 3 Please refer to PF65.	Pr	200	0~32767	ms																										
PF68	DLY4	Delay time of reached position 4 Please refer to PF65.	Pr	300	0~32767	ms																										
PF69	DLY5	Delay time of reached position 5 Please refer to PF65.	Pr	500	0~32767	ms																										
PF70	DLY6	Delay time of reached position 6 Please refer to PF65.	Pr	600	0~32767	ms																										
PF71	DLY7	Delay time of reached position 7 Please refer to PF65.	Pr	800	0~32767	ms																										
PF72	DLY8	Delay time of reached position 8 Please refer to PF65.	Pr	1000	0~32767	ms																										
PF73	DLY9	Delay time of reached position 9 Please refer to PF65.	Pr	1200	0~32767	ms																										
PF74	DLY10	Delay time of reached position 10 Please refer to PF65.	Pr	1500	0~32767	ms																										
PF75	DLY11	Delay time of reached position 11 Please refer to PF65.	Pr	2000	0~32767	ms																										
PF76	DLY12	Delay time of reached position 12 Please refer to PF65.	Pr	2300	0~32767	ms																										
PF77	DLY13	Delay time of reached position 13 Please refer to PF65.	Pr	2500	0~32767	ms																										
PF78	DLY14	Delay time of reached position 14 Please refer to PF65.	Pr	3000	0~32767	ms																										
PF79	DLY15	Delay time of reached position 15 Please refer to PF65.	Pr	4000	0~32767	ms																										
PF80	DLY16	Delay time of reached position 16 Please refer to PF65.	Pr	5000	0~32767	ms																										
PF81	PDEC	Deceleration time of auto protection function.	Pr.Pt S.T	00000000h	0~~ F0F0FFFFh	-																										
		<p>Parameters set into eight bit of D、C、B、A、W、Z、Y、X (hexadecimal): Including:</p> <p>1. Deceleration time of auto protection function.OVF, CTO, time-out,SPL, SNL, PL, NL</p> <table border="1"> <thead> <tr> <th>Bit</th> <th>D</th> <th>C</th> <th>B</th> <th>A</th> <th>W</th> <th>Z</th> <th>Y</th> <th>X</th> </tr> </thead> <tbody> <tr> <td>Function</td> <td>STP</td> <td>reserved</td> <td>CTO</td> <td>reserved</td> <td>SNL</td> <td>SPL</td> <td>NL</td> <td>PL</td> </tr> <tr> <td>Range</td> <td>0~F</td> <td>-</td> <td>0~F</td> <td>-</td> <td>0~F</td> <td>0~F</td> <td>0~F</td> <td>0~F</td> </tr> </tbody> </table> <p>0~F is used to index deceleration time of PF49~PF64. For example, X is set to A; the deceleration time of PL is determined by PF58.</p>						Bit	D	C	B	A	W	Z	Y	X	Function	STP	reserved	CTO	reserved	SNL	SPL	NL	PL	Range	0~F	-	0~F	-	0~F	0~F
Bit	D	C	B	A	W	Z	Y	X																								
Function	STP	reserved	CTO	reserved	SNL	SPL	NL	PL																								
Range	0~F	-	0~F	-	0~F	0~F	0~F	0~F																								
PF82 (■)	PRCM	Pr command trigger register	Pr	0	0~~1000	-																										
		<p>Write 0, start to home return. Write 1 ~ 63, start to operate assigned PR program which equal to DI : CTRG+POSn. Write 64 ~ 9999, writing prohibition.(Value out of normal range) Write 1000, operate stop which equal to DI : STOP. While Reading : If the command does not complete, then read the original command. If the command has completed, then read the original command +10000. If the command has been completed and the DO: TPOS ON motor position reached then read the original command +20000. For example : Write positioning command 3, trigger the PR program 3. Read 3, that 3 execution of a program is not completed; If 10003 is read as the program 3 command sent, but unfinished motor positioning; If 20003 is read, as the program 3 command sent, and motor positioning is complete.</p>																														

No	Abbr.	Function description	Control Mode	Initial Value	Setting range	unit
PF83	EVON	Upper edge-triggered PR program number	Pr	0000h	0000h~DDDDh	-
		Parameter function : 4 bit : UZYX Set EVx is ON, operate PR number. X=0 : When EV1 is ON, do nothing. X=1~D : When EV1 is ON, operate PR No.51~63 Y=0 : When EV2 is ON, do nothing. Y=1~D : When EV2 is ON, operate PR No.51~63 Z=0 : When EV3 is ON, do nothing. Z=1~D : When EV3 is ON, operate PR No.51~63 U=0 : When EV4 is ON, do nothing. U=1~D : When EV4 is ON, operate PR No.51~63				
PF84	EVOF	Low edge-triggered PR program number	Pr	0000h	0000h~DDDDh	-
		Parameter function : 4 bit : UZYX Set EVx is ON, operate PR number. X=0 : When EV1 is OFF, do nothing. X=1~D : When EV1 is OFF, operate PR No.51~63 Y=0 : When EV2 is OFF, do nothing. Y=1~D : When EV2 is OFF, operate PR No.51~63 Z=0 : When EV3 is OFF, do nothing. Z=1~D : When EV3 is OFF, operate PR No.51~63 U=0 : When EV4 is OFF, do nothing. U=1~D : When EV4 is OFF, operate PR No.51~63				
No	Abbr.	Function description	Control Mode	Initial Value	Setting range	unit
PF85 (■)	PMEM	PATH#1 ~ PATH#2 data is not memorized settings when power off. Parameter function : 4 bit : 00YX X=0 : PATH#1 data is memorized settings when power off. X=1 : PATH#1 data is not memorized settings when power off. Y=0 : PATH#2 data is memorized settings when power off. Y=1 : PATH#2 data is not memorized settings when power off. Remaining reserves. This parameter provides users to constantly write new goal points through communication.	Pr.Pt S.T	0000h	0000h ~ 0011h	-
PF86	SWLP	Soft limit :forward When Motor moved forward and feedback the position that over the setting value of this parameter would trigger alarm code AL14 in PR mode.	Pr	$2^{31}-1$	$-2^{31}+1$ ~ $2^{31}-1$	pulse
PF87	SWLN	Soft limit :reverse When Motor moved reverse and feedback the position that over the setting value of this parameter would trigger alarm code AL15 in PR mode.	Pr	$2^{31}-1$	$-2^{31}+1$ ~ $2^{31}-1$	pulse
PF88 ~ PF99	Reserved					

Digital input (DI) function definition

Sign	Initial value	Functions/Applications description
SON	0x01	As this signal is on, the servo drive is ready to be operated.
RES	0x02	As particular alarm occurred, this signal recovers from an abnormal status.
PC	0x03	This signal could switch proportion-integral speed control to proportion one.
TL	0x 04	This signal could switch torque limit from inner limit 1 to external analog limit.
TL1	0x 05	Turn TL1-SG on to make inner torque limit 2 valid.
SP1	0x 06	Speed command/limit option 1.
SP2	0x 07	Speed command/limit option 2.
SP3	0x 08	Speed command/limit option 3.
ST1/RS2	0x 09	In speed control mode, drive will rotate "forward" when the signal activated. In torque control mode, drive will rotate "reverse" when the signal activated.
ST2/RS1	0x0A	In speed control mode, drive will rotate "reverse" when the signal activated. In torque control mode, drive will rotate "forward" when the signal activated.
ORGP	0x0B	In position control with inner registers, the arbitrary position could be assigned as the origin when this signal activated.
SHOM	0x0C	As this signal activated, the drive runs motor to return the present origin.
CM1	0x0D	Electronic gear numerator option 1
CM2	0x0E	Electronic gear numerator option 2
CR	0x0F	Used to clear the position command pulse errors on its rising edge. The width of pulse must be 10ms or more than 10ms.
CDP	0x10	Turn CDP on to change the gain into the multiplier of PB14 to PB17.
LOP	0x11	It is used to switch varied mode as hybrid control mode applied.
EMG	0x12	Turn it off to bring to an emergency stop and turn it on to reset that state.
POS1	0x13	Position command option 1
POS2	0x14	Position command option 2
POS3	0x15	Position command option 3
CTRG	0x16	Used to switch the 8 inner register position commands.
HOLD	0x17	As this signal activated, the motor would stop running when the Pr mode is applied.
Sign	Initial value	Functions/Applications description
LSP	0x18	Limit of forward rotation route
LSN	0x19	Limit of reverse rotation route
POS4	0x1A	Position command option 4
POS5	0x1B	Position command option 5
POS6	0x1C	Position command option 6
INHP	0x1D	Pulse inhibit input
EV1	0x1E	Event trigger Pr command 1
EV2	0x1F	Event trigger Pr command 2
EV3	0x20	Event trigger Pr command 3
EV4	0x21	Event trigger Pr command 4
ABSE	0x22	Absolute encoder function 1
ABSC	0x23	Absolute encoder function 2
STOP	0x24	As this signal activated, the motor would stop running when the Pr mode is applied.

Digital output (DO) function definition

Sign	Initial value	Functions/Applications description
RD	0x01	As the drive is ready to be operated, RD-SG would become conductive.
ALM	0x02	ALM-SG is isolated as power off or protection activated to cut off the main circuit. Without alarm occurring, ALM-SG would turn on after power on 1 second latter.
INP/SA	0x 03	In position mode, INP-SG is conductive as position errors is under permissible range. In speed mode, SA-SG is conductive as the motor speed has nearly attained.
HOME	0x 04	HOME-SG is on after the completion of home moving.
TLC/VLC	0x 05	In speed mode, TLC-SG is on as motor generated torque reaches inner torque limit or torque analog limit. TLC-SG is off when SON signal is turned off. In torque mode, VLC-SG is on as motor speed reaches inner speed limit or speed analog limit. VLC-SG is off Servo drive signal is turned off.
MBR	0X06	When using this signal, make it usable by setting parameter PA01 as 0100. MBR is off as the power is turned off or any alarm occurred.
WNG	0x 07	WNG-SG is conductive as any warning occurred. Without warning occurring, WNG-SG is isolated
ZSP	0x 08	When motor speed is under the preset of zero speed, ZSP-SG keeps conductive.
CMDOK	0x 09	CMDOK-SG is conductive as the inner position command is completed or stopped.
OLW	0x0A	When reaching the overload setting(PA17), this DO is ON
MC_OK	0x0B	When CMDOK and INP is both ON, this DO is ON.
OVF	0x0C	When motor position command pulse is more than $2^{31}-1$ or less than -2^{31} , this DO is ON.
SWPL	0x0D	When the motor feedback pulse more than software forward limit (PF86), this DO is ON.
SWNL	0x0E	When the motor feedback pulse less than software reverse limit (PF87), this DO is ON.
ABSW	0x0F	Absolute encoder related alarm is from this DO output.

Note: DO output logic level can be set to determine the output PD27 a normal open or normal close b.

9. Communication functions

9-1. Communication interface and wiring

Shihlin servo drive equips the RS-232C, RS-485 and plug-play USB serial communication functions. These functions could be used to perform servo operation, parameter changing, monitor function, etc. However, the RS-232C and RS-485 communication could not be used simultaneously. Use the parameter PC21 to select between RS-232C and RS-485. The wiring is demonstrated below.

RS-232C

(1)Outline :

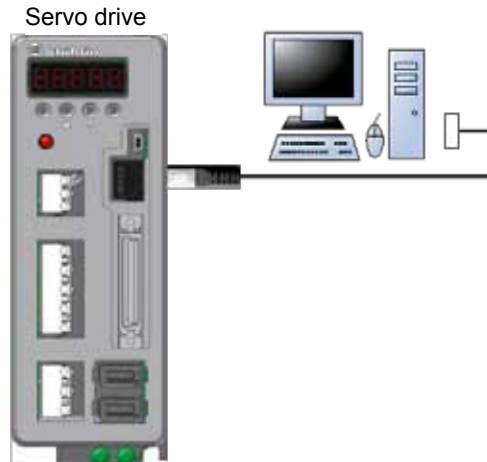

One device applied.

(2)Wiring diagram:

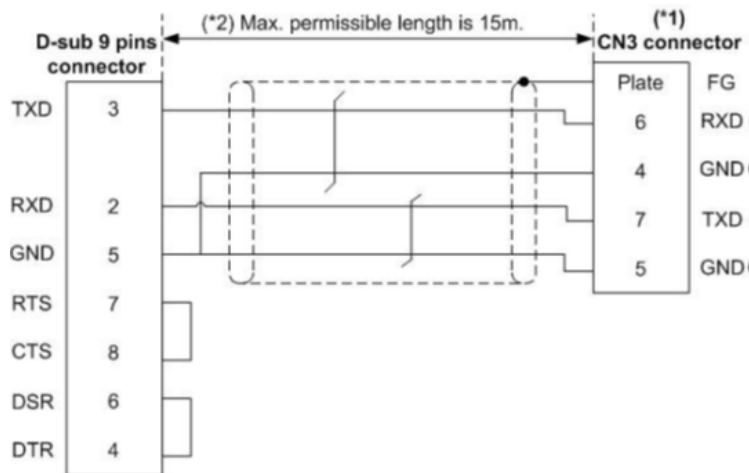

- 1 : CN3 connector is the RJ-45 type.
- 2 : Suitable for the environment with less noise interference. If communication transmission speed is higher than 38400bps, use the wires shorter than 3m.

RS-485

(1)Outline :

Up to 32 devices of driveServo Drives from stations 1 to 32 could be operated on the same bus.

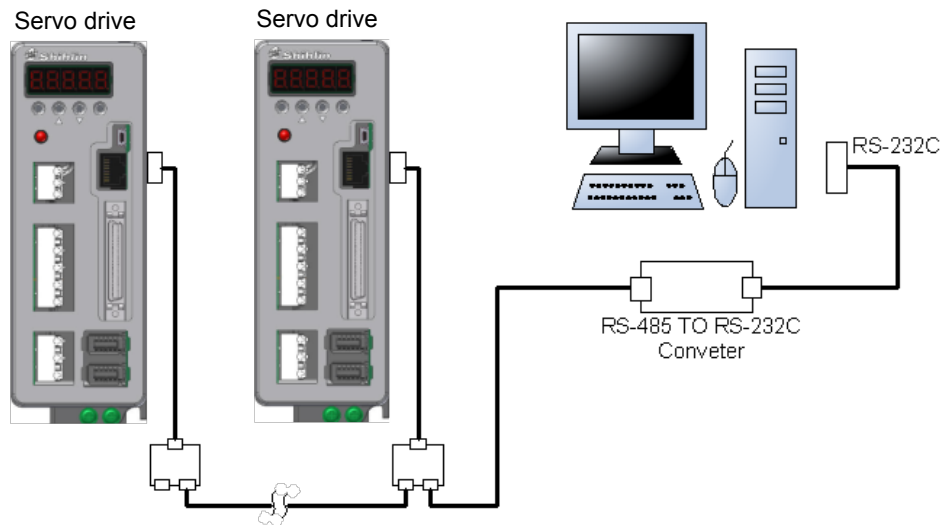

(2)Wiring diagram :

Recommendation: To connect ground terminal of RS-485/RS-232 converter and GND (pin4, pin5) of CN3 could reduce communication failure if necessary.

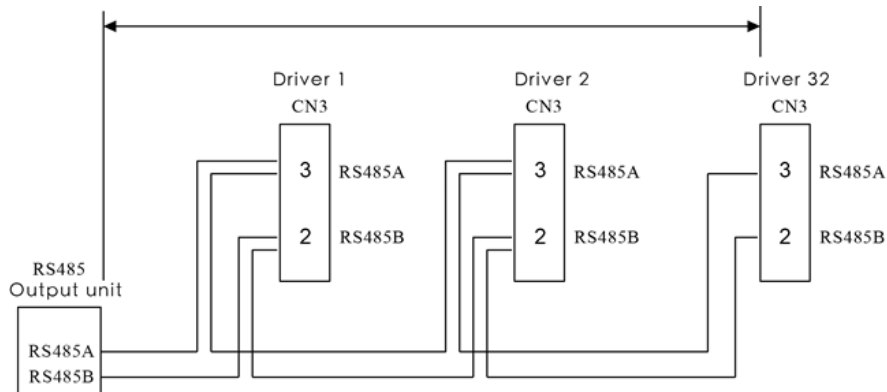

Note: Suitable for the environment with less noise interface.
If communication transmission speed is higher than 38400bps,
use the wires shorter than 15m.

USB

(1)Outline :

Use the standard Mini-USB cable to perform.

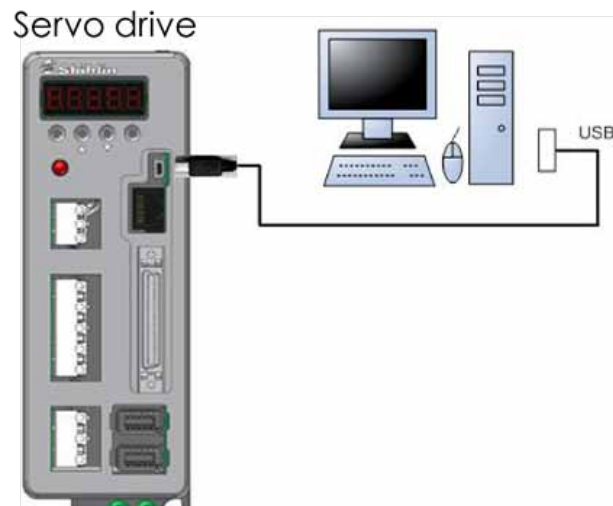

9.2 Relevant parameters of communication

As RS-232C/RS-485 communication is performed, the related settings are described below.

(1) Communication device number (PC20)

Please refer to Parameter PC-20 and setting range is form 1 to 32.

(2) RS-232C/485 communication interface selection and reply delay time setting (PC21)

0	0	y	x
---	---	---	---

x=0 : RS-232C x=1 : RS-485

(3) Communication reply time delay (PC21)

0	0	y	x
---	---	---	---

y=0 : reply within1ms y=1 : reply after 1ms

(4) Communication protocol option (PC22)

0	0	y	x
---	---	---	---

x=0 : 7 data bit · No parity · 2 Stop bit	(Modbus : ASCII Mode)
x=1 : 7 data bit · Even parity · 1 Stop bit	(Modbus : ASCII Mode)
x=2 : 7 data bit · Odd parity · 1 Stop bit	(Modbus : ASCII Mode)
x=3 : 8 data bit · No parity · 2 Stop bit	(Modbus : ASCII Mode)
x=4 : 8 data bit · Even parity · 1 Stop bit	(Modbus : ASCII Mode)
x=5 : 8 data bit · Odd parity · 1 Stop bit	(Modbus : ASCII Mode)
x=6 : 8 data bit · No parity · 2 Stop bit	(Modbus : RTU Mode)
x=7 : 8 data bit · Even parity · 1 Stop bit	(Modbus : RTU Mode)
x=8 : 8 data bit · Odd parity · 1 Stop bit	(Modbus : RTU Mode)

(5) Baud rate (PC22)

0	0	y	x
---	---	---	---

y=0 : 4800bps ; y=1 : 9600bps ; y=2 : 19200bps
y=3 : 38400bps ; y=4 : 57600bps ; y=5 : 115200bps

9.3 Modbus protocol

When communication between a computer and several drives is going to be performed, every drive should have its device number of PC20 setting. Then the computer could control individual drive according to its device number. The protocol of Shihlin drive is Modbus protocol. There are two modes : ASCII(American Standard Code for information interchange) mode and RTU (Remote Terminal Unit) mode · users could change the mode by setting the PC21 value.

Shihlin drives support Modbus Function Codes there is 0x03, 0x04, 0x06, and 0x10, can be related to host communication control.

ASCII mode

(a) Coding signification

An 8-bit data (a byte) is expressed with 2 ASCII character. For example, 75h is expressed with ASCII code "37h"of '7' and ASCII code "35h"of '5'.

(b) frame signification

11 bit frame (suitable for 8-bit data length)

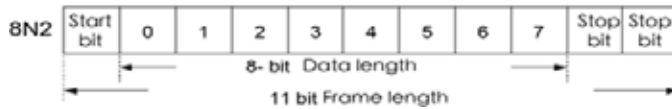
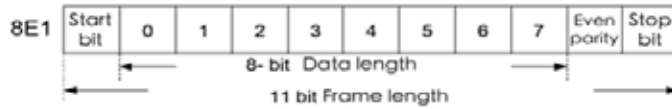
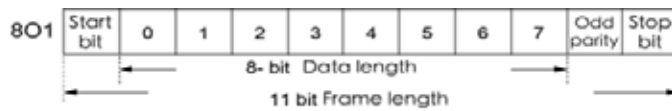

10-bit frame (suitable for 7-bit data length)

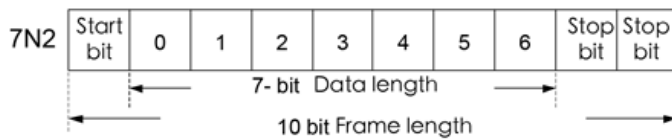
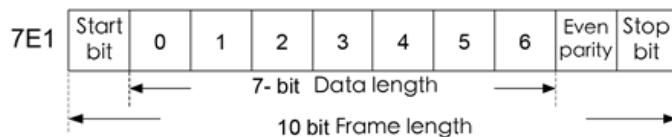
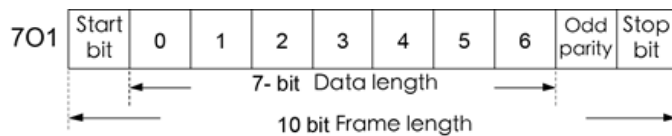
**(3) Data packet structure**

Bit Sign	Name	Description
STX	Start code	“ : ”(3AH of ASCII)
ADR	Device number	1 byte is composed of 2 ASCII code bytes.
CMD	Command code	1 byte is composed of 2 ASCII code bytes.
DATA(n-1)	Data code	The length of n words is equal to the one of 2n bytes.(n<=29) So, there are 4n ASCII code bytes.
.....		
DATA(0)		
LRC	LRC check value	1 byte is composed of 2 ASCII code bytes.
End1	End code 1	0DH of ASCII (CR)
End0	End code 0	0AH of ASCII (LF)

Communication data formats are described below.

STX (Start code)
':' character

ADR (Device number)

The address code is from 1 to 32. For example, communicate with device number 18(hexadecimal 12h)
ADR='1','2' => '1'=31H · '2'=32H

CMD and DATA

The DATA are varied according to different Command codes. Command codes for common use are described below.

Example 1 · Command code : 03H, read data (N word)

The maximum of N is 29; for example : To read 2 words which start address is 0100h from device number 01H as an example is described below.

Command(host) :

STX	:
ADR	0
	1
CMD	0
	3
start address	0
	1
	0
	0
word length	0
	0
	0
	2
LRC	F
	9
End1	0DH(CR)
End0	0AH(LF)

Response(slave) :

STX	:
ADR	0
	1
CMD	0
	3
byte length (byte)	0
	4
content of address 0100h	0
	1
	0
content of address 0101h	2
	1
	2
LRC	D
	2
End1	0DH(CR)
End0	0AH(LF)

Example 2 · Command code : 06H · write data (1 word)

For example : To write "100" (0064h) into the drive which device number is 01H and start address is 0100H.

Command(host) :

STX	:
ADR	0
	1
CMD	0
	6
start address	0
	1
	0
	0
written data	0
	1
	4
	5
LRC	B
	2
End1	0DH(CR)
End0	0AH(LF)

Response(slave) :

STX	:
ADR	0
	1
CMD	0
	6
start address	0
	1
	0
	1
written data	0
	2
	1
	2
LRC	B
	2
End1	0DH(CR)
End0	0AH(LF)

Example 3 · Command code : 10H · write data (multiple words)

For example : To write 2 words "0BB8H and 0000H" into the drive which device number is 01H and start address is 0112H which means that 0112H is written into 0BB8H, 0113H is written into 0000H. The maximum allowable written data are 10 at one time.

Command(host) :

STX	:
ADR	0
	1
CMD	1
	0
start address	0
	1
	1
	2
written data (word)	0
	0
	0
	2
written data (byte)	0
	4
First data content	0
	B
	B
Second data content	8
	0
	0
	0
LRC	1
	3
End1	0DH(CR)
End0	0AH(LF)

Response(slave) :

STX	:
ADR	0
	1
CMD	0
	6
start address	0
	1
	0
	0
written data	0
	1
	4
	5
LRC	B
	2
End1	0DH(CR)
End0	0AH(LF)

LRC calculation (ASCII mode) :

ASCII mode uses LRC (Longitudinal Redundancy Check) to detect errors. LRC method computes the 2's complement of the sum from ADR code to the last data code. The 2's complement is a byte value which the overflow part neglected. Here is a case to describe the rule.

For example : To read 2 words which start address is 0104h from device number 01H as an example is described below.

$$01H+03H+01H+04H+00H+02H = 0BH$$

The 2's complement of 0BH is F5H, so LRC is 'F', '5'.

STX	:
ADR	0
	1
CMD	0
	6
start address	0
	1
	0
	4
data written	0
	0
	0
	2
LRC debug	F
	5
End1	0DH(CR)
End0	0AH(LF)

End1、End0 (data packet ended)

Use '\r' 『 carriage return 』 of "0Dh" and '\n' 『 new line 』 of "0Ah" to denote the end of communication data packet.

RTU mode

Coding signification

Data are expressed in hexadecimal characters. For example, 1-byte is expressed as data 62H. Data packet structure

Bit sign	Name	Description
STX	Start	To keep an idle more than 6mS
ADR	Device number	1 byte
CMD	Command code	1 byte
DATA(n-1)	Data code	n-word = 2n-byte · n<=29
.....		
DATA(0)		
CRC	Command code	1 byte
End	End code	To keep an idle more than 6mS

STX (Communication start)

To keep an idle more than 6mS.

ADR (Communication address)

The address code is from 1 to 32. For example · number "18" is expressed as ADR=12H.

CMD and DATA

The DATA are varied according to different Command codes.

Command code used as commonly follows:

Example 1: Command code: 03h, read data

The biggest N id29. Example : to read 2 words which start address is 0200h from device number 01H is described below.

Command(host) :

ADR	01H
CMD	03H
start address	02H(high byte)
	00H(low byte)
word length	00H
	02H
CRC debug low byte	C5H(low byte)
CRC debug high byte	B3H(high byte)

Response(slave) :

ADR	01H
CMD	03H
byte length	04H
content of address 0100H	00H(high byte)
	B1H(low byte)
content of address 0101H	1FH(high byte)
	40H(low byte)
CRC debug low byte	A3H(low byte)
CRC debug high byte	D4H(high byte)

Example 2 · Command code:06H · write data (1 word)

Example : to write "100" (0064H) into the drive which device number 01H and start address 0200h.

Command(host) :

ADR	01H
CMD	06H
start address	02H(high byte)
	00H(low byte)
word length	00H(high byte)
	64H(low byte)
CRC debug low byte	89H(low byte)
CRC debug high byte	99H(high byte)

Response(slave) :

ADR	01H
CMD	06H
start address	02H(high byte)
	00H(low byte)
word length	00H(high byte)
	64H(low byte)
CRC debug low byte	89H(low byte)
CRC debug high byte	99H(high byte)

Example 3 · Command code:10H · write data (multiple words)

For example : To write 2 words“0BB8H and 0000H” into the drive which device number is 01H and start address is 0112H which means that 0112H is written into 0BB8H, 0113H is written into 0000H. The maximum allowable written data are 10 at one time.

Command(host) :

ADR	01H
CMD	10H
start address	01H(high byte)
	12H(low byte)
word length (word)	00H(high byte)
	02H(low byte)
byte length	0BH(high byte)
content of first address	B8H(low byte)
content of second address	00H(high byte)
	00H(low byte)
CRC debug low byte	FCH(low byte)
CRC debug high byte	EBH(high byte)

Response(slave) :

ADR	01H
CMD	10H
start address	01H(high byte)
	12H(low byte)
word length	00H(high byte)
	02H(low byte)
CRC debug low byte	E0H(low byte)
CRC debug high byte	31H(high byte)

CRC (RTU mode) calculation :

RTU mode uses CRC (Cyclical Redundancy Check) to detect errors.
CRC method to decide the check value is described below.

Step 1: Load a 16-bit register (called CRC register) with FFFFh.

Step 2: Exclusive OR the first 8-bit byte of the command message with the lower byte of CRC register, putting the result in the CRC register.

Step 3: Check the LSB of CRC register. If it is 0, shift the CRC register one bit to the right. If it is 1, shift the CRC register one bit to the right then Exclusive OR the CRC register with A001h.

Step 4: Repeat step 3 until eight shifts have been performed. When this is done, a complete 8-bit byte will have been processed, then perform step 5.

Step 5: Repeat step 2 to step 4 for the next 8-bit byte of the command message. Continue doing this until all bytes have been processed. The final contents of the CRC register are the CRC value. It should be noticed that the low-byte should be transmitted before high-byte.

For example, reading 2 words from address 0101h of the drive with address 01H. The final content of the CRC register from ADR to last data character is 3794H and then the command message is shown as follows. What should be noticed is that 94H have to be transmitted before 37H.

ADR	01H
CMD	03H
start address	01H(high byte)
	01H(low byte)
written data	00H(high byte)
	02H(low byte)
CRC debug low byte	94H(low byte)
CRC debug high byte	37H(high byte)

End1 · End0 (Communication finish)

To keep an idle more than 6mS.

CRC calculation example :

The following is an example of CRC generation using C language. The function takes two variables.

unsigned char* data;

unsigned char length

This function returns the CRC value as unsigned integer type.

```
unsigned int crc_chk(unsigned char* data, unsigned char length)
```

```
{
```

```

int j;
unsigned int reg_crc=0xFFFF;
while( length-- )
{
    reg_crc^= *data++;
    for (j=0; j<8; j++ )
    {
        if( reg_crc & 0x01 ) /*LSB(bit 0 ) = 1 */
            reg_crc = (reg_crc >> 1)^0xA001;
        else
            reg_crc = (reg_crc>>1);
    }
}
return reg_crc;
}

```

(b)Command code and exception code

The Command code and exception code of Shihlin servo drive are described below.

Command code	Description
03H	Read data
04H	Only read data (Only read)
06H	Write data(one word)
10H	Write data(Maximum 10 words)

Command code 03h denotes data reading, the maximum permissible length is 29 words.

Command code 04h denotes data only reading, the maximum permissible length is 29 words.

Command code 06h denotes data writing, a word length writing.

Command code 10h denotes data writing, the maximum permissible length is 10 words.

exception code	Description
01	Command code error
02	Parameter address error
03	Parameter range error

Exception code 01h denotes wrong command code transmitted from the host computer.

Exception code 02h denotes wrong parameter address transmitted from the host computer. The parameter address range is from 0x0000 to 0x20FF.

Exception code 03h denotes the over-range parameter setting request. The range judgment of parameter value is as follows:

1. Check if reading data is out of range. The data (word) range is form 1 to 29 words.
2. Check if writing data exceeds the range of data that has be defined. When current communication addresses is from 0x0000 to 0x20FF, almost address has been defined its range, if some addresses are not in use, the range is form -32,728 to 32767.

If the received data are wrong, the drive would send back the command code which is the original one added to 0x80.

(a)ASCII mode

STX	:
Slave Address	'0'
	'1'
Function	'6'
	'3'
Exception code	'0'
	'2'
LRC CHK	'7'
	'7'
END1	CR
END0	LF

(b)RTU mode

Slave Address	01H
Function	86H
Exception code	02H
CRC CHK Low	C3H
CRC CHK High	A1H

9.4 Communication parameter write-in and read-out

(1)Status monitor_(read only)

Address	Content	Data length
0x0000	Motor feedback pulse [pulse]	2word
0x0002	Cumulative pulses of command[pulse]	2word
0x0004	Accumulative pulses error [pulse]	2word
0x0006	Command pulse frequency [kHz]	2word
0x0008	Motor speed [rpm]	2word
0x000A	Speed analog command/limit voltage [V] (the second digit after the decimal point)	2word
0x000C	Speed command / limit [rpm]	2word
0x001E	Torque analog command/limit voltage [V] (the sencond digit after the decimal point)	2word
0x0010	Torque command/limit [%]	2word
0x0012	Effective load ratio [%]	2word
0x0014	Peak load ratio [%]	2word
0x0016	DC Bus voltage [V]	2word
0x0018	The ratio of load inertia to motor shaft [times] (the first digit after the decimal point)	2word
0x001A	Instantaneous torque [%]	2word
0x001C	Regenerative load ratio [%]	2word
0x001E	Fully closed encoder feedback pluses [pulse]	2word
0x0020	Absolute pulse relative to encoder z-phase [pulse] (<u>Note1</u>)	2word
0x0022	Command pulse number (after electric gear ratio) [pulse]	2word
0x0024	Feedback pulse number (before electric gear ratio) [pulse]	2word
0x0026	Accumulative pulses error (before electric gear ratio) [pulse]	2word

Note1: Absolute pulse relative to z-phase of encoder means that the origin value of Z phase is 0 and could be form positive 5000 to negative 5000 pulse, The drawing shown below.

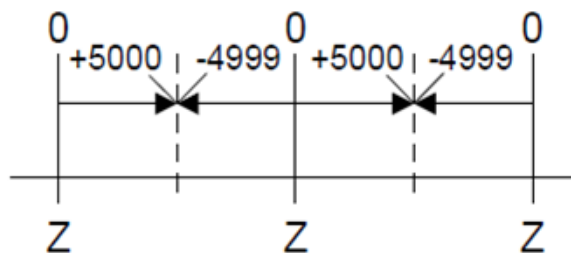

Every 10000 pulse per pitch between two Z.

(2) Digital IO monitor (read only)

(a) IO pin status

Address	Content	Data length
0x0204	The ON/OFF status of DI and DO. The pin location is as follows.	1word

Bit7	Bit6	Bit5	Bit4	Bit3	Bit2	Bit1	Bit0	Bit No.
DI8	DI7	DI6	DI5	DI4	DI3	DI2	DI1	Signal name
Bit15	Bit14	Bit13	Bit12	Bit11	Bit10	Bit9	Bit8	Bit No.
			DI12	DI11	DI10	DI9	DI8	Signal name

Note: The status of digital IO is integrated status of DI source, control switch (PD16) and communications source (PD25), please see the following samples.

External hardware terminal DI12~DI1 represented by bit11~bit0.

Bit binary for description :bit11~bit0 represent DI12~DI1 (left to right)

Digital input contact source switch (PD16): 111111000000

External hardware terminal status: 111100001111 (1 represent ON · 0 represent OFF)

Communication control digital input contact status (PD25) : 111000111000

Based on the above, The status of digital IO (address 0x0204), and the pin DI12~DI7 are determined by communications source (PD25) status and the pin DI6~DI1 are determined by External hardware terminal status.

So the final digital IO status (address 0x0204) is 111000 001111.

Address	Content	Data length
0x0205	The ON/OFF status of DI and DO. The pin location is as follows.	1word

Bit7	Bit6	Bit5	Bit4	Bit3	Bit2	Bit1	Bit0	Bit No.
		DO6	DO5	DO4	DO3	DO2	DO1	Signal name

(b) IO pin function

Address	Content	Data length
0x0206~0x020D	To display the pin function programmed of DI and DO	1word

Attention: If the input/output signal function is not suitable for current control mode, then send back 0.

Ex: If it is in speed control mode, PD07=0x000B, then bit0~bit7 of Address 0x0208 must send back 0.

Address : 0x0206

Bit8~Bit15	Bit0~bit7	Bit No.
DI1	DI2	Signal name
0x00~0x2F	0x00~0x2F	Function

Address : 0x0207

Bit8~Bit15	Bit0~bit7	Bit No.
DI3	DI4	Signal name
0x00~0x2F	0x00~0x2F	Function

Address : 0x0208

Bit8~Bit15	Bit0~bit7	Bit No.
DI5	DI6	Signal name
0x00~0x2F	0x00~0x2F	Function

Address : 0x0209

Bit8~Bit15	Bit0~bit7	Bit No.
DI7	D8	Signal name
0x00~0x2F	0x00~0x2F	Function

Address : 0x020A

Bit8~Bit15	Bit0~bit7	Bit No.
DI9	D10	Signal name
0x00~0x2F	0x00~0x2F	Function

Address : 0x020B

Bit8~Bit15	Bit0~bit7	Bit No.
DI11	DI12	Signal name
0x00~0x2F	0x00~0x2F	Function

Address : 0x020C

Bit10~Bit14	Bit5~bit9	Bit0~bit4	Bit No.
DO3	DO2	DO1	Signal name
0x00~0x1F	0x00~0x1F	0x00~0x1F	Function

Address : 0x020D

Bit10~Bit14	Bit5~bit9	Bit0~bit4	Bit No.
DO6	DO5	DO4	Signal name
0x00~0x1F	0x00~0x1F	0x00~0x1F	Function

(c) Current control mode

Address	Content	Data length
0x0200	Bit0 : servo drive is ready (0:Servo OFF, 1:Servo ON)	1word
0x0201	Bit0~Bit3 : To display current control mode of servo drive. 0 : Pt mode 1 : Pr mode (inner register command in absolute type) 2 : Pr mode (inner register command in incremental type) 3 : S mode 4 : T mode 5Fully closed loop control mode	1word

Note 1 : DI function definition

0x07	0x06	0x05	0x04	0x03	0x02	0x01	0x00	Function code
SP2	SP1	TL1	TL	PC	RES	SON	-	Sign
0x0F	0x0E	0x0D	0x0C	0x0B	0x0A	0x09	0x08	Function code
CR	CM2	CM1	SHOM	ORGP	ST2/RS1	ST1/RS2	SP3	Sign
0x17	0x16	0x15	0x14	0x13	0x12	0x11	0x10	Function code
	CTRG	POS3	POS2	POS1	EMG	LOP	CDP	Sign
0x1F	0x1E	0x1D	0x1C	0x1B	0x1A	0x19	0x18	Function code
EV2	EV1	INHP	POS6	POS5	POS4	LSN	LSP	Sign
			0x24	0x23	0x22	0x21	0x20	Function code
			STOP	ABSC	ABSE	EV4	EV3	Sign

Note 2 : DO function definition

0x05	0x04	0x03	0x02	0x01	0x00	Function code
TLC/VLC	HOME	INP/SA	ALM	RD	-	Sign
0x0B	0x0A	0x09	0x08	0x07	0x06	Function code
MC_OK	OLW	CMDOK	ZSP	WNG	MBR	Sign
		0x0F	0x0E	0x0D	0x0C	Function code
		ABSW	SWNL	SWPL	OVF	Sign

(3) Alarm information (read only)

Address	Content	Data length
0x0100	Current alarm.	1word
0x0101	The last alarm.	1word
0x0102	The 2nd alarm in the past.	1word
0x0103	The 3rd alarm in the past.	1word
0x0104	The 4th alarm in the past.	1word
0x0105	The 5th alarm in the past.	1word
0x0106	The 6th alarm in the past.	1word

Note : When 0x00ff was sent back means no alarm, 0x0001 means AL.01, 0x0012 means AL.12 and so on.

(4) Alarm clear (readable and writable)

Address	Content	Data length
0x0130	Clear current alarm if "0x1EA5" is written into this address. Transmit current alarm code back if this address is read. The setting range is 0~0xFFFF.	1word
0x0131	Clear all alarm histories if "0x1EA5" written data is address. Transmit last alarm back if this address is read. The setting range is 0~0xFFFF.	1word

(5) Parameter write-in and read-out (readable and writable)

Address	Content	Data length
0x0300~0x0363	There are 50 parameters in PA group. The data length of every parameter is 32 bit which takes two words. For example, PA01 : 0x0300~0x0301.	2word
0x0400~0x0463	There are 50 parameters in PB group. The data length of every parameter is 32 bit which takes two words. For example, PB01 : 0x0400~0x0401.	2word
0x0500~0x0577	There are 60 parameters in PC group. The data length of every parameter is 32 bit which takes two words. For example, PC01 : 0x0500~0x0501.	2word
0x0600~0x064F	There are 40 parameters in PD group. The data length of every parameter is 32 bit which takes two words. For example, PD01 : 0x0600~0x0601.	2word
0x0700~0x07C5	There are 99 parameters in PE group. The data length of every parameter is 32 bit which takes two words. For example, PE01 : 0x0700~0x0701.	2word
0x0800~0x08C5	There are 99 parameters in PE group. The data length of every parameter is 32 bit.	2word

Note: The maximum read ability is 29 words.

(6) Factory-set recovery (readable and writable)

Address	Content	Data length
0x0140	All parameters would be recover factory-set as3 second latter after "0x1EA5" being written. The setting range is 0~0xFFFF. To read this address, the result of "1" means the recovery is processing. "0" means the completion of recovery.	1word

(7) DI contact control (readable and writable)

Step 1: Select DI contact control option

Address	Content	Data length
0x061E	DI contact source control switch (PD16) The input signal source of DI is determined by every one bit of this parameter: Bit0 ~ Bit11 correspond to DI1 ~ DI12. Bit setting as follows: 0 : according to actual input state. 1 : controlled by communication command (Parameter PD25)	2 word

Step 2: Write-in command to control ON/OFF state of each DI pin

Address	Content	Data length
0x061E	DI contact source control switch (PD16) The input signal source of DI is determined by every one bit of this parameter: Bit0 ~ Bit11 correspond to DI1 ~ DI12. Bit setting as follows: 0 : according to actual input state. 1 : controlled by communication command (Parameter PD25)	2 word

Bit7	Bit6	Bit5	Bit4	Bit3	Bit2	Bit1	Bit0	Bit No.
SDI8	SDI7	SDI6	SDI5	SDI4	SDI3	SDI2	SDI1	Pin name
Bit12~Bit31					Bit11	Bit10	Bit9	Bit8
bit value must be "0"					SDI12	SDI11	SDI10	SDI9

Attention : Consideration of test mode (DO forced output 、 JOG test 、 Positioning test)

As test mode is performed, check the following items or servo drive could not be operated normally.

1. As no alarm occurred nor Servo ON activated, test mode could be performed.
2. If communication is interrupted over 1 second during test mode, drive would quit this test mode. The host could repeatedly read-out at "0x0900" address to keep a continuous communication.

(8) DO forced output (readable and writable)

Step 1: To check if alarm occurred or Servo ON activated by reading at address "0x0900".

Address	Content	Data length
0x0900 (Only read)	0x0UVW, UV=Alarm code; W=1 means SON is ON; W=0 means SON is OFF.	1word

Step 2: Enter in forced DO mode, and write-in 0x0002 at address "0x0901" to perform this test.

Address	Content	Setting range	Data length
0x0901	Mode switch 0000 : To quit the test mode 0001 : Preserved 0002 : DO forced output 0003 : JOG test 0004 : Positioning test	0000~0004	1word

Note: Write 0x0002~0x0004 into 0x090 cannot enter in test mode if it is Servo ON.

Step 3: To write in test data at address "0x0203" to enforce output.

Address	Content	Setting range	Data length				
0x0203	To control DO status by the written data (ON/OFF) which as follows.	0~0x003F	1word				
Bit6~Bit15	Bit5	Bit4	Bit3	Bit2	Bit1	Bit0	Bit No.
	DO6	DO5	DO4	DO3	DO2	DO1	Pin No.

Step 4: To quit this mode by 0x0000 written at "0x0901" address.

(9)JOG test (readable and writable)

Step 1: o check the drive without alarm did not occur nor Servo ON activated.

Address	Content	Data length
0x0900 (Only read)	0x0UVW, UV=Alarm code; W=1 means SON is ON; W=0 means SON is OFF.	1word

Step 2: To write-in 0x0003 at address "0x0901" to perform this mode.

Step 3: To set acceleration/deceleration time constant of JOG test

Address	Content	Data length
0x0902	JOG · Acceleration/deceleration time constant of positioning test (Setting range:0~20000) (Unit:ms)	1word

Step 4: JOG speed command and start

Address	Content	Data length
0x0903	JOG · speed command of positioning test(Setting range:0~6000)(Unit:rpm)	1word

Step 5: JOG Forward/Reverse/Stop command

Address	Content	Data length
0x0904	0: Written 0 to stop motor running. 1: Written 1 to make motor run forward rotation.(CCW) 2: Written 2 to make motor run reverse rotation.(CW) Setting range:0~2	1word

Step 6: To quit this mode by 0x0000 written at address "0x0901".

(10) Positioning test (readable and writable)

Step 1: To check the drive without alarm occurred nor Servo ON activated.

Address	Content	Data length
0x0900 (Only read)	0x0UVW, UV=Alarm code; W=1 means SON is ON; W=0 means SON is OFF.	1word

Step 2: To write-in 0x0004 at address "0x0901" to perform this positioning test.

Step 3: To set the acceleration/deceleration time constant of positioning test.

Address	Content	Data length
0x0902	JOG · the acceleration/deceleration time constant of positioning test. (Setting range:0~20000) (Unit:ms)	1word

Step 4: To set speed command of positioning test.

Address	Content	Data length
0x0903	JOG · speed command of positioning test (Setting range:0~3000)(Unit:rpm) ·	1word

Step 5: To set the pulse of positioning test.

Address	Content	Data length
0x0905~ 0x0906	Pulse of positioning test (0x0905 feedback low 16 bit and 0x0906 feedback high 16 bit)Setting range: 0 ~ (2 ³¹ -1) (Unit: pulse)	1word

Step 6: Positioning test Forward/Reverse/Stop command

Address	Content	Data length
0x0907	0: Written 0 to pause/stop motor running.(twice pause command to stop motor running) 1: Written 1 to make motor run forward rotation.(CCW) 2: Written 2 to make motor run reverse rotation.(CW) (Setting range:0~2)	1word

Step 7: To quit this mode by 0x0000 written at address "0x0901".

10. Inspection and Maintenance

10.1 Basic Inspection

It is recommended for users to inspect the following items periodically. Operate the inspection after the drive is power off and charge light of drive is off.

- Inspect the screws of the drive, terminal block and the connection to mechanical system. Tighten screws as necessary as they may be loosen.
- Avoid to locate drive in place with inflammable gas.
- Avoid to locate conductive objects beside the drive and wirings.
- Avoid any naked wires or damaged, broken wires applied for the servo motor.
- Ensure that all wiring terminals are correctly insulated.
- Ensure that the external applied power voltage is AC 220V.
- Ensure that "START" button is OFF.
- Ensure that all wiring instructions and recommendations are followed, otherwise damage to the drive and or motor may result.

10.2 Maintenance

Users should not disassemble the servo drive or motor as maintenance performing. Please refer to following regular maintenance:

- Periodically clean the surface of servo drive and motor
- Operate the servo drive and motor within the specified environmental condition range.
- Clean off any dust and dirt that accumulated on the ventilation holes of servo drive

10.3 Life of consumable components

Some components inside servo drive are consumable and must be replaced periodically. The life of consumable components are varied, which depend on operating methods and environmental conditions. For parts replacement, please contact your sales agent. The life of particular components are listed below.

Component	Life guideline	Description
Relay	100.000 times	The contact would wear due to switching currents. Relays reach the end of its life at cumulative 100,000 switching times, which depends on the power supply capacity.
Cooling fan	10.000~ 30.000hrs (2~3years)	The cooling fan bearings reach the end of their life in 10,000 to 30,000 hours. It should be replaced if noise is found during inspection.
Aluminum capacitor	10 years	Affected by ripple currents and deteriorates in characteristic. Its life greatly depends on ambient temperature and operating conditions. The capacitor will reach the end of its life in 10 years of continuous operation in normal air-conditioned environment.

11. Troubleshooting

CAUTION An alarm occurs, please make sure that all alarm was cleared to ensure safety then operate. Otherwise it will lead to accidental injury easily.

Caution:

As the following alarms occur, please do not power OFF → ON to clear alarm and start repeatedly, otherwise it will cause damage to the drive or servo motor.

Please place the driver aside and let cool off for more than 15 minutes while to clear the following alarms.

AL.04(Abnormal regeneration)

AL.05(Overload 1)

AL.10(Overload 2)

Please place the driver aside and let cool off for more than 30 seconds while to clear the following alarms.

AL.03(Over current)

11.1 Alarm list

The drive would display alarm or warning if some faults occurred during operation. As an alarm or a warning occurred, please remedy the fault according to the instruction mentioned in section 11.2 When parameter PD19 is set as 1, alarm codes could be output via the ON/OFF states of DO1 (CN1_41), DO2 (CN1_42), DO5 (CN1_45) terminals.

	Sign	Alarm code			Name	Clear		
		CN1 41	CN1 42	CN1 45		Power OFF→ON	Press "SET" on alarm screen.	RES signal
Alarm	AL.01	0	1	0	Over voltage	○		
	AL.02	0	0	1	Low voltage	○	○	○
	AL.03	0	1	1	Over current	○		
	AL.04	0	1	0	Abnormal regeneration	○	○	○
	AL.05	1	0	0	Overload1	○	○	○
	AL.06	1	0	1	Over speed	○	○	○
	AL.07	1	0	1	Pulse command abnormal	○	○	○
	AL.08	1	0	1	Position error excess	○	○	○
	AL.09	0	0	0	Communication abnormal	○	○	○
	AL.0A	0	0	0	Communication time-out	○	○	○
	AL.0B	1	1	0	Encoder error 1	○		
	AL.0C	1	1	0	Encoder error 2	○		
	AL.0D	1	1	0	Fan error	○		
	AL.0E	0	0	0	IGBT overheat	○		
	AL.0F	0	0	0	Memory error	○		
	AL.10	0	0	0	Overload 2	○		
	AL.11	1	1	1	Motor mismatched	○		
	AL.20	1	1	1	Motor crash error	○		
	AL.21	1	1	1	Motor U/V/W disconnect	○		
	AL.22	1	1	0	Encoder communication error	○		
	AL.23	0	1	0	Full-close position error excess	○	○	○
	AL.24	0	0	0	Encoder mismatched	○		
	AL.25	1	1	0	Linear scale disconnect	○		

	AL.26	1	1	0	Encoder error 3	○		
	AL.27	1	1	0	Encoder error 4	○		
	AL.28	1	1	0	Encoder overheat	○		
	AL.29	1	1	0	Encoder error 5(overflow)	○		
	AL.2A	1	1	0	Absolute encoder error 1	○		
	AL.2B	1	1	0	Absolute encoder error 2	○		
	AL.2E	0	1	1	Control loop error	○		
	AL.2F	0	1	1	Regenerative energy error	○		
	AL.30	0	1	1	Pulse output frequency excess	○	○	○
	AL.31	0	1	1	Over current 2	○		
	AL.32	0	1	1	Control loop error 2	○		
	AL.33	0	1	1	Memory access error	○		
	Warn	AL.12				Emergency stop	Removing the cause would clear the warning automatically.	
AL.13					LSP/LSN abnormal			
AL.14					Software LSP trigger			
AL.15					Software LSN trigger			
AL.16					Overload pre-warning			
AL.17					ABS time-out warning			
AL.18					Over regeneration warn	Home returning		
AL.1A					Index coordinate undefined	Removing the cause would clear the warning automatically.		
AL.1B					Position offset warn	Removing the cause would clear the warning automatically.		
AL.61					Parameter group excess	○	○(Note 1)	○
AL.2C					Absolute encoder error 3	Removing the cause would clear the warning automatically.		
AL.2D					Encoder battery low voltage	Removing the cause and re-power on		
AL.62					Parameter number excess○	○	○	○
AL.63				Pr relevant parameter overflow	○	○	○	
AL.64				Pr relevant parameter error	○	○	○	

Note1: Turn drive to “Servo OFF” than “Servo ON” to remove this alarm.

11.2 Alarm cause and remedy

AL.01 Over voltage

Definition : Main circuit bus voltage has exceeded its maximum allowable value.

Cause	Inspection	Remedy
Power supply voltage high	Review the power supply.	Use proper power source.
Input power error(incorrect power)	Review the power supply.	Use proper power source.
Drive hardware damaged.	Use voltmeter to check if the power voltage is within rated voltage while error still occurred.	Contact agent for proper service.
Lead of built-in regenerative brake resistor or regenerative brake option is disconnected.	Check the P,D terminals connected well or not. Check built-in regenerative brake resistor or regenerative brake option is disconnected well.	Connect correctly.
Built-in regenerative brake resistor or regenerative brake option is damaged.	Check if it is burn out or damaged.	Change the built-in resistor or option.
Capacity of built-in regenerative brake resistor or regenerative brake option is insufficient.	Refer to section 6.6.1 to check if the capacity insufficient.	Add regenerative brake option or increase capacity.

AL.02 Low Voltage

Definition : Main circuit bus voltage is lower than its allowable value.

Cause	Inspection	Remedy
Input voltage of main circuit is lower than permissible value.	Review the power supply.	Use proper power source.
Capacity of power supply is insufficient.	Check if it occurred as motor torque regenerated huge.	Increase power supply capacity.
Input power error (incorrect power).	Review the power supply.	Use proper power source.

AL.03 Over current

Definition : The motor output current has exceeded the allowance range of servo drive.

Cause	Inspection	Remedy
Improper motor wirings.	Check the wirings.	Correct the wirings.
Short occurred in drive output phases U, V and W.	Check if the connection between drive and motor is short.	Correct the wirings to prevent from short-circuit or cable naked.
IGBT of servo drive faulty.	AL03 occurs if power is switched on after U,V and W are disconnected	Contact agent for proper service.
Improper parameters setting.	Check relevant parameters which have modified.	Recover factory-set then re-define user's demand.

AL.04 Regenerative alarm

Definition : Regenerative energy suppression circuit faults

Cause	Inspection	Remedy
Brake transistor fault.	Set PC36 to be 0 and re-power on, if AL04 is occurred soon, it means the brake transistor broken.	Contact agent for proper service.
Built-in brake resistor or brake option is disconnected.	Check the wirings.	Correct the wirings.
The active time of brake resistor is over the PC36 value.	when AL04 occurred, reset PC36 to be zero and re-power on; if motor runs a while then AL04 occurred again, it means capacity of built-in brake resistor is insufficient.	Use the external brake resistor and refer to section 14.2 to set a proper PC36 value.

AL.05 Overload1

Definition : Load exceeded overload protection characteristic of servo drive.

Cause	Inspection	Remedy
Operate the servo drive in heavy duty continually.	Check if mechanism load is huge.	Upgrade the capability of servo or reduce the duty.
Improper gain values setting.	Check if vibration of mechanism is occurred.	Re-operate the auto-gain tuning job to obtain the proper gain value.
Servo system is instable.	Check if acceleration/deceleration time constant is proper.	Extend these setting values.
Position encoder \ motor wiring error	As motor shaft is rotated slowly with Servo OFF, the pulses feedback should vary in proportion to rotary angle. If the indication skips or returns midway, it is faulty.	Contact agent for proper service.

AL.06 Over speed

Definition : Speed has exceeded the instantaneous permissible speed.

Cause	Inspection	Remedy
Input command pulse frequency exceeded the permissible instantaneous speed frequency.	Check if frequency of input pulse is over the permissible speed range.	Set pulses frequency correctly.
Improper acceleration/ deceleration time constant settings.	Check if these values are too small.	Increase acceleration/deceleration time constant.
Servo system is instable to cause overshoot.	Observe if the mechanism is with vibration.	1. Re-set proper servo gain value. 2. If gain could not be set to proper: 1) Reduce load inertia ratio; or 2) Set acceleration/deceleration time constant to proper value.
Electronic gear ratio is large	Check if the settings are proper.	Set correctly.

AL.07 Pulse command abnormal

Definition : Input pulse frequency of the command pulse is too high.

Cause	Inspection	Remedy
Pulse frequency of the command pulse is too high.	Check if input pulse frequency is over range with frequency detector.	1. Set the command pulse frequency to a proper value. 2. After RD output signal activated, the host starts to send command.
Command device failure.	Check if the command device is normal or not.	Change the command device.

AL.08 Position error excessive

Definition : Position error has exceeded the permissible error range.

Cause	Inspection	Remedy
Improper acceleration/ deceleration time constant settings.	Check if these values are too small	Increase acceleration/deceleration time constant.
Improper torque limit setting	Check if PA05 setting is too small.	Increase the torque limit value.
Position loop gain value is small	Check if PB07 setting is too small.	Increase the gain value and adjust to ensure proper operation.
Mechanism load is huge.	Check if mechanism load is huge.	Reduce load, or to use servo drive and motor provide larger output.

AL.09 Communication abnormal

Error content : RS-232/485 communication error occurred between host device and servo drive.

Cause	Inspection	Remedy
Improper protocol setting.	Check if the protocol is matched	Set the protocol correctly.
Improper address setting.	Check the communication address.	Set the address correctly.
Improper data content transmitted.	Check the value accessed.	Correct the data content accessed

AL.0A Communication time-out

Definition : RS-232/485 communication stopped for longer time exceeded the permissible range.

Cause	Inspection	Remedy
Cable broken or loosen.	Check if cable broken or loosen.	Replace or re-connect the cable.
Communication cycle is longer than parameter PC23 setting.	Check if PC23 setting is proper.	Set the PC23 correctly.

AL.0B Encoder error 1

Definition : Pulse signals abnormal between servo motor and servo drive.

Cause	Inspection	Remedy
Wirings are in wrong sequence	Check if wirings sequence is correct or not.	Correct the wirings.
CN2 connector is loosen or disconnected.	Check if CN2 connector is loosen or disconnected.	Re-connect CN2 connector.
Encoder wirings faulty	Check the encoder feedback pulses continuity of motor while Servo OFF	Contact agent for proper service.

AL.0C Encoder error 2

Definition : Pulse signals abnormal between servo motor and servo drive.

Cause	Inspection	Remedy
Initial magnetic polarity of encoder is in wrong position	Rotate the motor shaft forward and backward then re-power on the drive. If there is still no improvement, contact agent for proper service.	
CN2 connector is loosen or disconnected.	Check if CN2 connector is loosened or disconnected.	Re-connect CN2 connector.

AL.0D Fan error

Definition : Abnormal operation of cooling fan.

Cause	Inspection	Remedy
Cooling fan stops working.	Change the fan by user or contact agent for proper service.	

AL.0E IGBT overheat

Definition : Main circuit device overheat or fault.

Cause	Inspection	Remedy
Operate the drive in over-rate duty continuously.	Operate the drive in over-rate duty continuously.	Operate the drive in over-rate duty continuously.

AL.0F Memory error

Definition : EEPROM fault.

Cause	Inspection	Remedy
Data read-out/write-in abnormally.	To execute the parameter recovery or power on reset and check if it still null.	Contact agent for proper service.

AL.10 Overload 2

Definition : The output duration of maximum current is over 1 second while mechanical impact.

Cause	Inspection	Remedy
Mechanical impact	Check if the moving route is proper.	1. Correct the moving route. 2. Install limit switches.
Wrong connection of servomotor.	Check the wirings.	Correct the wirings.
Mechanism vibration.	Check if mechanism is instable and humming.	1. Change response level setting. 2. Make gain adjustment manually.
Encoder faulty.	To rotate motor shaft and check the continuity of encoder feedback pulses while Servo OFF.	Contact agent for proper service.

AL.11 Motor dispatch

Definition : The servo drive and servo motor match improperly.

Cause	Inspection	Remedy
The capacity of drive and motor are not compatible.	Check if they match for each other in capacity.	Use the proper combination.

AL.12 Emergency stop warning

Error content : The EMG signal of DI is activated.

Cause	Inspection	Remedy
EMG signal is activated.	Check if EMG signal is applied and triggered.	Release the trigger after removal of some emergency conditions.

AL.13 LSP/LSN abnormal

Definition : The LSP or LSN signal of DI is activated.

Cause	Inspection	Remedy
LSP activated.	Check if the limit switch is activated.	Release the activated cause of limit switch.
LSN activated.	Check if the limit switch is activated.	Release the activated cause of limit switch.

AL.14 Software LSP trigger

Definition : The software LSP is activated.

Cause	Inspection	Remedy
The motor feedback pulses are over the software LSP PF86.	Check if the software limit switch is activated. Refer to the PF86 usage.	Recover the motor feedback pulses to be less than the software LSP.

AL.15 Software LSN trigger

Definition : The software LSN is activated.

Cause	Inspection	Remedy
The motor feedback pulses are less than the software LSN PF87.	Check if the deceleration time is proper or not. Check if the motor shaft is locked or not.	Recover the motor feedback pulses to be large than the software LSP.

AL.16 Overload pre-warning

Definition : The overload level set is activated.

Cause	Inspection	Remedy
The motor load exceeds the permissible operation time	Check if the motor is overload or not. Check if the setting of PA17 is too less or not.	1. Refer to the remedy of AL05. 2. Disable this pre-protection or to set a higher PA17 value.

AL.17 ABS time-out warning

Cause	Inspection	Remedy
The absolute position signal exceeds the time limit.	Delta DIO Communication : Check if when the drive data is ready (ABSR), the upper PC is no signal required more than five seconds (ABSQ) in absolute position communication situation. Mitsubishi DIO Communication : please refer to section 14.1.5 (Output error) .	Turn ABSE or ABSM signal terminal OFF and check if the upper PC communication format is correct or not.

AL.18 Excessive regeneration warning

Cause	Inspection	Remedy
When regeneration load rate reach 100%.	Check if there are forward/reversal rotations continuously in a short duration, which would lead to large power poured into regenerative resistor.	This problem will be solved automatically when regeneration load rate < 85%. (Note 1)

Note 1 : If this warning occurs frequently within a short time, do not re-power on, otherwise it will cause regenerative resistor overload .

AL.19 PR command error

Cause	Inspection	Remedy
Positioning command register overflows.	Incremental system : PR mode continuously operates in one direction and causes feedback register overflows. And the coordinate system cannot reflect the correct position. If issuing the absolute positioning command (except incremental) at this time, the error will occur. Absolute system : This error will occur in following situations : 1. The position feedback register is overflow 2.Change the electronic gear ratio (PA06 ` PA07) and homing procedure has not been executed. 3.Operate Absolute Positioning Command when DO HOME is OFF.	Conduct homing procedure.

AL.20 Motor Crash Error

Cause	Inspection	Remedy
When motor current reaches setting value of PA15 and exceeds the time set by PA16.	1. Check if PA15 is enabled. 2. Check if PA15 is set too small and the time of PA16 is set too short.	1. If it is enabled by mistake, please set PA15 to zero. 2. According to the actual torque setting, if the value is set too small, it will lose the function of protection.

AL.21 Incorrect wiring of the motor power line U, V, W

Cause	Inspection	Remedy
Short occurred in servo motor power (U, V, W)	Check if U, V, W of the motor is incorrect connected.	Follow the user manual to correct the wiring.

AL.22 encoder communication error

Cause	Inspection	Remedy
CRC error occurs three times continuously, or internal memory is error.	<ol style="list-style-type: none"> 1. Check if the servo is properly grounded. 2. Check if the encoder cable separates from the power supply or the high-current circuit to avoid the interference. 3. Check if the shielding cables are used in the wiring of the encoder. 	<ol style="list-style-type: none"> 1. Please connect the UVW connector (color green) to the heat sink of the servo drive. 2. Please check if the encoder cable separates from the power supply or the high-current circuit. 3. Please use shielding mesh. 4. If the situation is not improving, please contact agent for proper service.

AL.23 Excessive deviation of full closed-loop position control

Cause	Inspection	Remedy
Excessive deviation pulse of position control exceeds PA25 setting value.	<ol style="list-style-type: none"> 1. Check if PA25 is set too small. 2. Check if the connector is loose or there is any connection problem of other mechanism. 	<ol style="list-style-type: none"> 1. Increase the value of PA25. 2. Check if the connection is well connected.

AL.24 Wrong motor type

Cause	Inspection	Remedy
Incremental motor is not allowed to activate the absolute function.	<ol style="list-style-type: none"> 1. Check if the motor is incremental or absolute encoder. 2. Check the setting of PA28. 	If users desire to use absolute function, please choose absolute motor. If not, please set parameter PA28 to 0.

AL.25 The communication of linear scale is breakdown

Cause	Inspection	Remedy
When PA26 = 0001 or 0002 and motor is on Servo ON situation as the linear scale feedback pulse >500 pulse, but actual linear scale feedback pulse <3 pulse, AL.25 occurs.	Check the communication of linear scale.	Check the communication of linear scale again.

AL.26 Encoder error 3

Cause	Inspection	Remedy
Encoder LED lumens depreciation or encoder internal counter are in error.	Re-power on the servomotor and check if this error occurs again.	If the situation is not improving, please contact agent for proper service.

AL.27 Encoder error 4

Cause	Inspection	Remedy
The internal memory of the encoder is in error.	<ol style="list-style-type: none"> 1. Check if the servo is properly grounded. 2. Check if the encoder cable separates from the power supply or the high-current circuit to avoid the interference. 3. Check if the shielding cables are used in the wiring of the encoder. 	<ol style="list-style-type: none"> 1. Please connect the UVW connector (color green) to the heat sink of the servo drive. 2. Please check if the encoder cable separates from the power supply or the high-current circuit. 3. Please use shielding mesh. 4. If the situation is not improving, please contact agent for proper service.

AL.28 Encoder overheat

Cause	Inspection	Remedy
Encoder operating temperature is over 95 °C .	Check the encoder is not in high temperature environment or close to the heat.	1.To avoid high temperature environment and lower the temperature of the encoder. 2. If the situation is not improving, please contact agent for proper service.

AL.29 Encoder error 5

Cause	Inspection	Remedy
The multi-turn of absolute encoder exceeds the range.	Check if the multi-turn of absolute encoder exceeds the maximum range: -32768 ~ +32767	Conduct homing procedure. Please refer to the description of absolute coordinate initialization in Chapter 14.

AL.2A Absolute encoder error 1

Cause	Inspection	Remedy
The voltage of the absolute encoder battery is lower than the specification.	Check if the voltage of the battery is lower than 2.45V (TYP).	After changing the battery, please conduct homing procedure. Please refer to the description of absolute coordinate initialization in Chapter 14 or parameter PA29.
Battery circuit disconnects or wire broken.	1. Check the wiring of the encoder. 2. Check the wiring between the battery pack and power cable of the servo drive.	After connecting battery to encoder correctly or repairing wiring, conduct homing procedure. Please refer to the description of absolute coordinate initialization in Chapter 14.

AL.2B absolute encoder error 2

Cause	Inspection	Remedy
The value of absolute encoder multi-revolution counter is abnormal.	Re-power on the servomotor and check if this error occurs again.	If the situation is not improving, please contact agent for proper service.

AL.2C absolute encoder error 3b

Cause	Inspection	Remedy
Change the battery when the power is OFF which is controlled by the servo drive.	Do not change or remove the battery power when the power is OFF which is controlled by the servo drive.	Conduct homing procedure. Please refer to the description of absolute coordinate initialization in Chapter 14 or parameter PA29.
Start up with absolute function and not have finished absolute coordinate initialization.	1. Install the battery. 2. Check the wiring between the battery pack and power cable of the servo drive. 3. Check the wiring of the encoder.	Conduct homing procedure. Please refer to the description of absolute coordinate initialization in Chapter 14 or parameter PA29.

AL.2D encoder battery under voltage

Cause	Inspection	Remedy
The voltage of the encoder is lower than the specification.	1. Check if the voltage of the battery on the panel is lower than 3.0V (TPY). 2. Check if the voltage of the battery is lower than 3.0V (TPY).	Change the battery when power is ON which is controlled by the servo drive. After changing the battery, AL. 2D will be cleared automatically.

AL.2E Control circuit error

Cause	Inspection	Remedy
When motor is running and external loading is bigger, the situation of servo ON (SON) OFF becomes ON instantly.	Check if servo ON (SON) turns on.	Turn on servo ON (SON) correctly.
Drive current feedback abnormal.	Re-power on the drive. If the situation is not improving, please contact agent for proper service.	

AL.2F Regeneration Error

Cause	Inspection	Remedy
When the regenerative load rate over 100%.	1. Check if the deceleration time is too short 2. Check if the frequency of reversing is too quick	1. Adjust the acceleration and deceleration time, or reduce the frequency of reversing. 2. Power off and re-power on.

AL.30 Encoder pulse output frequency is over

Cause	Inspection	Remedy
Encoder output abnormal because encoder error	Check alarm list record if there are also encoder error (AL0B、AL0C、AL22、AL26、AL27).	Conduct procedure of AL0B、AL0C、AL22、AL26、AL27
The input frequency of the pulse command is over the allowable value of the hardware interface.	Check if there are following situations: (a) Motor speed feedback > PA41 (b) (Motor speed / 60) x encoder output pulse every revolution > 20x10 ⁶	Set parameter PA41 correctly and PA14: PA41 > (motor speed / 60) x encoder output pulse every revolution < 20x10 ⁶

AL.31 Over current 2

Cause	Inspection	Remedy
Drive current feedback error	Re-power on the drive. If the situation is not improving, please contact agent for proper service.	

AL.32 Control circuit error 2

Cause	Inspection	Remedy
Programmable port array error	Re-power on the drive. If the situation is not improving, please contact agent for proper service.	

AL.33 Memory error 2

Cause	Inspection	Remedy
Cache memory is in error.	Re-power on the drive. If the situation is not improving, please contact agent for proper service.	

AL.1A Undefined of index coordinates

Cause	Inspection	Remedy
Conduct homing procedure to define index coordinates origin or the error will occurs.	Check if homing procedure conducted.	1. Before index function, please conduct homing procedure to prevent this error. 2. When the error occurs, conduct DI:Alm Reset to clear. 3. It's also useful on Servo ON.

AL.1B Offset

Cause	Inspection	Remedy
MC_Ok is ON and then becomes OFF. Please refer to the description of parameter PD28.	When DO : MC_OK was ON, and then DO : MC_OK become OFF because DO : INP becomes OFF. After finishing motor positioning may be subjected to an external force to push the position offset.	The alarm can be cleared with following methods: 1.Power OFF→ON 2.Press "SET "on current alarm screen 3.RES signal ON 4. SON signal OFF → ON

AL.61 Source parameter group is out of range

Cause	Inspection	Remedy
The group of PR command setting source exceeds the range.	Write parameters via PR procedure: group setting is over the range.	The alarm can be cleared with following methods: Power OFF→ON Press "SET "on current alarm screen RES signal ON

AL.62 Source parameter number is out of range

Cause	Inspection	Remedy
The numbers of PR command setting source exceeds the range.	Write parameters via PR procedure: group setting is over the range.	The alarm can be cleared with following methods: Power OFF→ON Press "SET "on current alarm screen RES signal ON

AL.63 PR program writing parameter exceeds the range

Cause	Inspection	Remedy
Write parameter with PR command TYPE 8 exceeds the range.	Write parameters via PR procedure: group setting is over the range.	The alarm can be cleared with following methods: 1.Power OFF→ON 2.Press "SET "on current alarm screen 3.RES signal ON

AL.64 PR program writing parameter error

Cause	Inspection	Remedy
Write parameter with PR command TYPE 8 as Servo ON.	Write parameters via PR procedure: when the servo is ON or the input data is unreasonable.	Correct the PR command and parameter

12. Specifications

12.1 Specifications of driveServo Drives

Type SDH-□□□A2	010	020	040	050	075	100	150	200	350
matched motor type SMH-□□□□	L010	L020	L040	M050	L075	M100	M150	M200	M350
Motor power	100W	200W	400W	500W	750W	1KW	1.5KW	2KW	3.5KW
Main circuit power	Voltage/Frequency	3φ 200 ~ 230VAC 50/60Hz or 1φ 230VAC 50/60Hz			3φ 200 ~ 230VAC 50/60Hz				
	Allowable voltage Range	3φ 170 ~ 253VAC 50/60Hz or 1φ 207 ~ 253VAC 50/60Hz			3φ 170 ~ 253VAC 50/60Hz				
	Allowable frequency Range	Maximum ±5%							
Control circuit power	Voltage/Frequency	1φ200 ~ 230VAC 50/60Hz							
	Allowable voltage Range	1φ170 ~ 253VAC 50/60Hz							
	Allowable frequency Range	Maximum ±5%							
	Power consumption(W)	30							
Control mode	3φ full-wave rectification, IGBT-PWM control (SVPWM)								
Dynamic brake	Built-in								
Protection Function	Over current, under voltage, over voltage, overheat, overload, fan failure protection, output short-circuit protection, abnormal encoder protection, abnormal regeneration protection, low voltage/power interruption protection, over speed protection, error excessive, short-circuit protection of terminal U, V, W and CN1, CN2, CN3								
Encoder type	incremental type: 22bit (4194304 p/rev) · absolute type:16bit (4194304 p/rev)								
Communication interface	RS232/RS485(MODBUS) · USB								
Position control mode	Input pulse frequency	Line drive : 500Kpps(Low speed)/4Mpps(high speed) Open collector:200kpps							
	Command pulse type	CCW pulse + CW pulse ; Pulse + Direction ; A phase + B phase,							
	Command source	External pulse train input/Inner register							
	Command smoothing	Low-pass filter/Linear acceleration and deceleration pattern/S-pattern smoothing							
	Electronic gear ratio	Electronic gear ratio A/B-time A/B time A : 1 ~ 2 ²⁶ 、B : 1 ~ 2 ²⁶ (condition:1/50 < A/B < 64000)							
	Position error excessive	±3 revolutions							
	Torque limit	Inner limit or torque analog limit (0~+10Vdc/Maximum torque)							
	Feed-forward function	Internal parameter setting: 0 ~ 200%							

Type SDH-□□□A2		010	020	040	050	075	100	150	200	350	
matched motor type SMH-□□□□		L010	L020	L040	M050	L075	M100	M150	M200	M350	
Motor power		100W	200W	400W	500W	750W	1KW	1.5KW	2KW	3.5KW	
Speed control mode	Speed control range	Speed analog command 1:2000 · Inner speed command 1:5000									
	Command source	Speed analog voltage input/ Inner register command									
	Command smoothing	Low-pass filter/Linear acceleration and deceleration pattern/S-pattern smoothing									
	Speed analog input	0 ~ ±10VDC/ Rated speed ((Input impedance 10 ~ 12kΩ)									
	Speed change rate	Load change 0 ~ 100% maximum ±0.01% Power source change ±10% maximum 0.01% · Ambient temperature 0°C ~55°C : Maximum ±0.5% (Speed analog command)									
	Torque limit	Inner limit or torque analog limit (0 ~ +10VDC/ Maximum torque)									
	Bandwidth	Maximum 1.6KHz									
Torque mode	Command source	Torque analog voltage input									
	Command smoothing	Low-pass filter									
	Torque analog input	0 ~ ±10VDC/ Max torque generated (Input impedance 10 ~ 12kΩ)									
	Speed limit	Inner limit or speed analog limit (0 ~ ±10VDC/ Maximum speed)									
Digital input/output signal	Digital input(DI)	Servo ON, forward and reverse rotation limit switch, pulse error clearing, torque direction option, speed command option, position command option, forward and reverse rotation command, proportional control switched, torque limit switched, abnormal alarm reset, emergency stop, control mode switching, electric gear ratio options, gain switching Servo on, Fault reset, Gain switch, Pulse clear, Zero clamp, Command input reverse control, Torque limit, Speed limit, Speed command selection, Speed / position mode switching, Speed / torque mode switching, Torque / position mode switching, Emergency stop, Positive/negative limit, Forward/reverse operation torque limit, Forward / reverse JOG input, E-gear N selection, Pulse input prohibition									
	Digital output(DO)	Torque limit attain, speed limit attain, ready signal, zero speed attained, position attained, speed attained, alarm signal, home moving completed Servo on, Servo ready, Zero speed, Target speed reached, Target position reached, Torque limiting, Servo alarm, Brake control, Early warning for overload, Servo warning									
	Analog input	Analog speed command / limit, analog torque command / limit									
	Analog output	Command pulse frequency, pulse error, current command, DC bus voltage, serve motor speed, torque value									
Cooling method(structure)		Nature air convention(IP20)					Fan force-cooling(IP20)				
Environment	Temperature	operating : 0°C ~ 55°C (If it is above 45°C forced cooling would be required) · storage : -20 ~ 65°C (non-freezing)									
	Humidity	operating 90% RH (non-condensing) · storage : below 90RH ((non-condensing)									
	Installation site	Indoor(no direct sunlight), no corrosive gas, no oil mist or dust, no flammable gas									
	Altitude	Max.1000m (3280ft) or lower above sea level									
	Vibration	Maximum 5.9m/s ²									
Weight (kg)		1.4	1.4	1.4	1.4	1.7	1.7	2.6	2.6	2.6	

2.2. Dimensions of driveServo Drives

Dimensions of driveServo Drives

SDH-010A2、SDH-020A2、SDH-040A2、SDH-050A2 (100W~500W)

unit [mm]

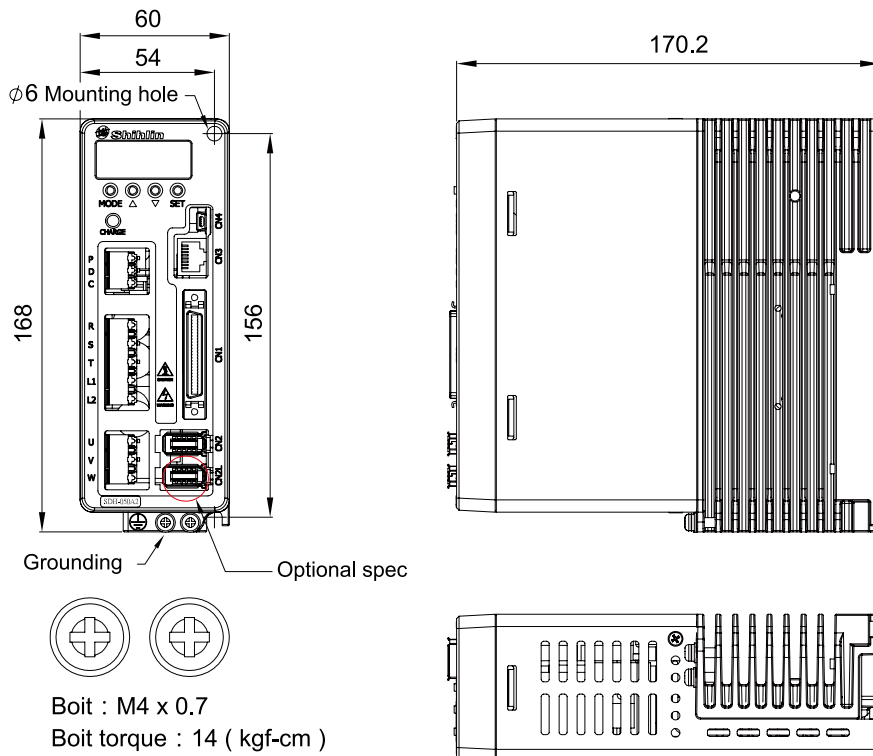

*Dimensions of the servo drive may be revised without prior notice

SDH-075A2、SDH-100A2 (750W、1KW)

unit[mm]

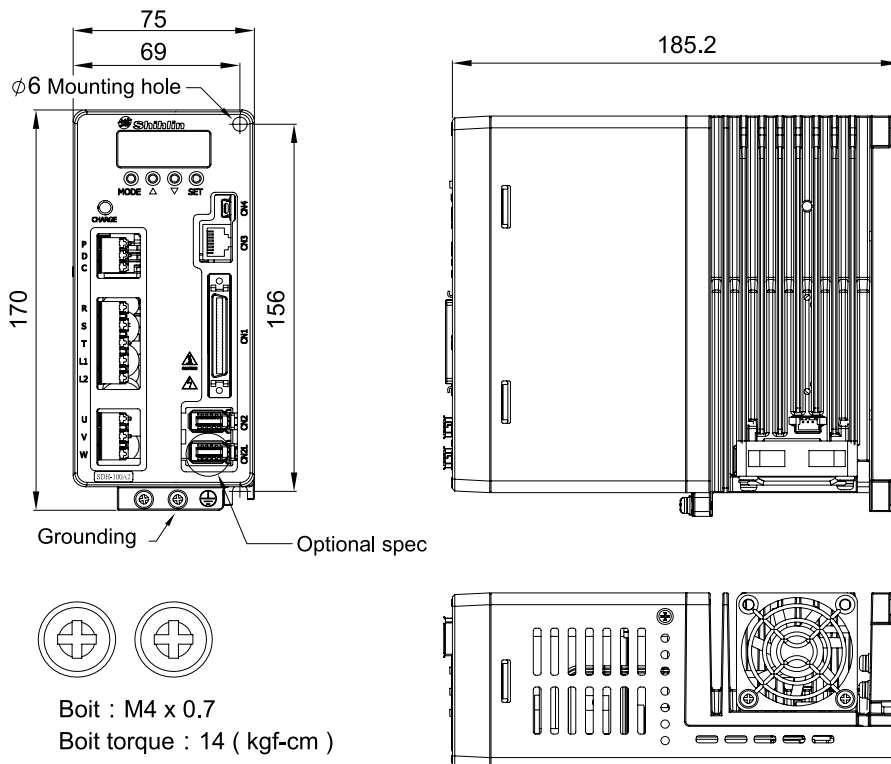

*Dimensions of the servo drive may be revised without prior notice

SDH-150A2、SDH-200A2、SDH-350A2 (1.5KW~3KW)

unit[mm]

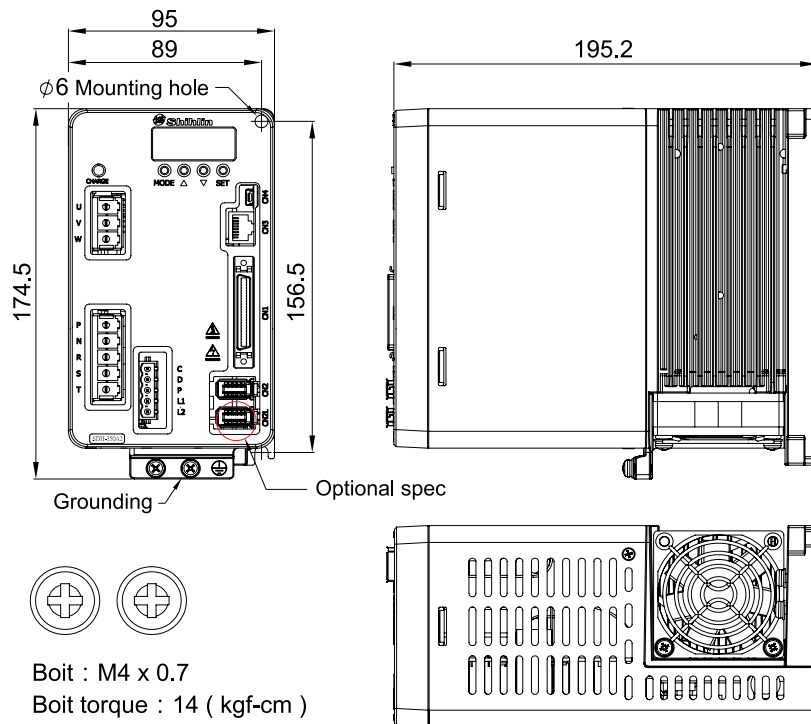

Dimensions of the servo drive may be revised without prior notice

SDH-500A2、SDH-700A2 (5KW~7KW)

unit[mm]

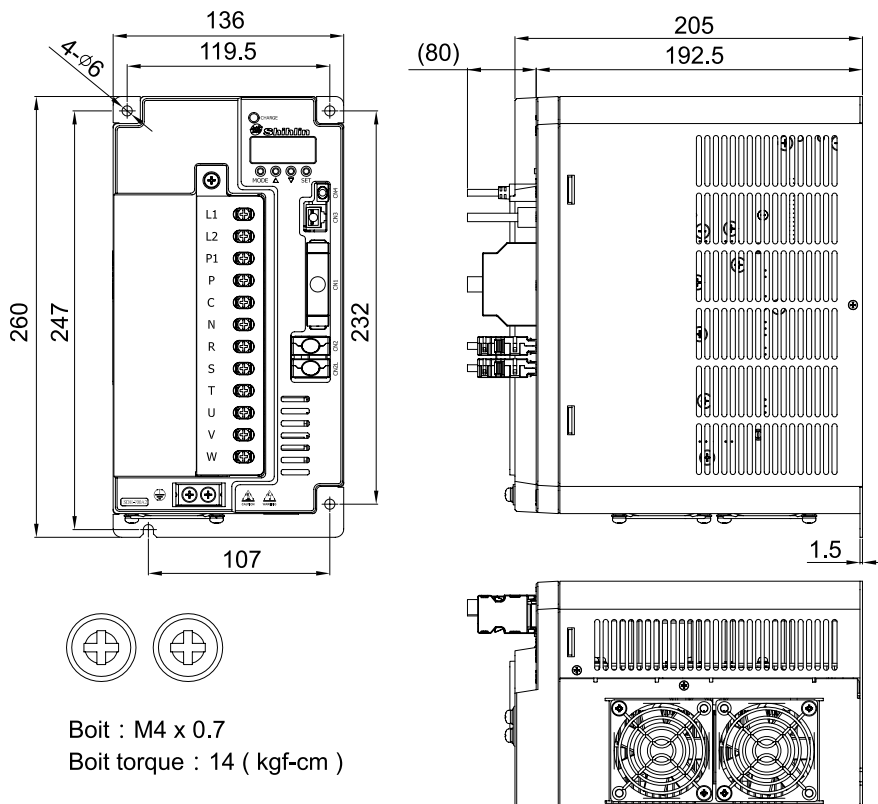

Dimensions of the servo drive may be revised without prior notice

12.3 Specifications of low inertia motors SMH-L□□□R30□□□ series

Type SMH-L□□□	010	020	040	075
Capacity of power supply (kVA)	0.3	0.5	0.9	1.3
Rated output power (W)	100	200	400	750
Rated torque (N·m)	0.32	0.64	1.27	2.4
Maximum torque (N·m)	0.96	1.92	3.81	7.2
Rated speed (r/min)	3000			
Maximum speed (r/min)	4500			
Instantaneous allowable speed (r/min)	5175			
Power rating (kW/s)	18.62	19.98	48.29	51.47
Rated current (A)	1.0	1.4	2.45	5.0
Max. instantaneous current (A)	3.0	4.2	7.35	15.0
Rotor inertia J (x10 ⁻⁴ kg·m ²)	0.055(0.058)	0.205(0.224)	0.334(0.354)	1.199(1.244)
Torque constantK _T (N·m/A)	0.32	0.46	0.52	0.48
Voltage constantK _E (V/Kmin ⁻¹)	41.0	54.5	59.8	56.0
Armature resistanceR _a (Ohm)	42.00	11.70	5.63	1.35
Armature inductanceL _a (mH)	44.25	42.10	22.95	9.83
Mechanical constant (ms)	1.84	1.01	0.64	0.59
Electric constant (ms)	1.05	3.51	4.08	7.28
Insulation class	F			
Insulation resistance	100MΩ,DC500V			
Insulation strength	AC1500V,60Hz,60sec			
Encoder	22bit (Absolute position is optional)			
Environment	Protection structure (IP)*	65		
	Temperature	0 ~ 40°C		
	Operating Humidity	80%RH or less(non-condensing)		
	Storage Temperature	-15 ~ 70°C		
	Storage Humidity	90%RH or less (non-condensing)		
	Vibration grade (μm)	V-15		
	Vibration capacity	x, y : 49 m/s ²		
Weight (kg)	0.36	0.83	1.28	2.70
() with electromagnetic brake	(0.56)	(1.26)	(1.71)	(3.44)
Approval				

Note: 1. The shaft-through portion is excluded.
 2. () Moment of Inertia with brake

12.4 Specifications of medium inertia motors SMH-M□□□R20□□□series

TYPE SMH-M□□□		050	100	150	200	350	500	700
Capacity of power supply (kVA)		1.0	1.7	2.5	3.5	5.5	7.5	10
Rated output power (kW)		0.5	1.0	1.5	2.0	3.5	5	7
Rated torque (N·m)		2.39	4.78	7.16	9.55	16.7	23.9	33.4
Maximum torque (N·m)		7.16	14.4	21.6	28.5	50.1	71.7	100.2
Rated speed (r/min)		2000						
Maximum speed (r/min)		3000			2500		2000	
Instantaneous allowable speed (r/min)		3450			2850		2300	
Power rating (kW/s) *		8.6	18.2	27.7	23.5	37.3	68	92
Rated current (A)		3.1	5.8	8.5	10	16	22	30
Max. instantaneous current (A)		9.3	16.8	25.5	30	48	66	90
Rotor inertia J (x10 ⁻⁴ kg·m ²)		6.59(8.55)	12.56(14.54)	18.52(20.61)	38.8(49.2)	74.8(85.2)	84.6(95)	121.6(132)
Torque constant K _T (N·m/A)		0.91	0.94	0.95	1.14	1.18	1.13	1.22
Voltage constant K _E (V/Kmin ⁻¹)		95.3	98.5	99.3	119.5	123.2	135.9	133.3
Armature resistance R _a (Ohm)		3.77	1.48	0.89	0.76	0.31	0.25	0.16
Armature inductance L _a (mH)		19.2	9.12	5.79	8.17	3.99	2.96	2.90
Mechanical constant (ms)		2.99	2.09	1.82	2.26	1.69	1.46	1.25
Electric constant (ms)		5.09	6.18	6.54	10.75	12.79	11.72	18.26
Insulation class		F						
Insulation resistance		100MΩ,DC500V						
Insulation strength		AC1500V,60Hz,60sec						
Encoder		22bit (Absolute position is optional)						
Environment	Protection structure (IP)*	65						
	Temperature	0 ~ 40°C						
	Operating Humidity	Below 80%RH (non condensing)						
	Storage Temperature	-15 ~ 70°C						
	Storage Humidity	Below 90%RH (non condensing)						
	Vibration grade (μm)	V-15						
Vibration capacity		x, y : 24.5 m/s ²						
Weight (kg)		4.6	6.7	8.8	11.4	17.5	19.1	24.5
() with electromagnetic brake		(6.4)	(8.5)	(10.6)	(16.7)	(22.8)	(24.4)	(29.8)
Approval								

Note: 1. The shaft-through portion is excluded.

2. () Moment of Inertia with brake

12.5 Dimensions of low inertia motor

【SMH-L010】

Model	L
SMH-L010(B)	88(122.3)

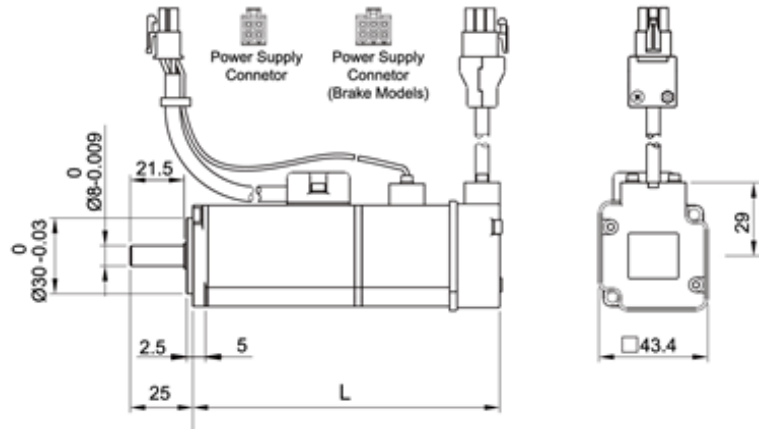
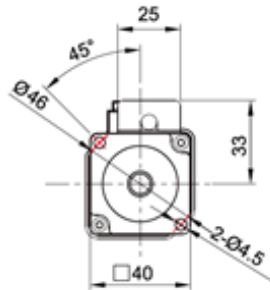

【SMH-L020 · L040】

Model	L
SMH-L020(B)	84.1(118.1)
SMH-L040(B)	109.6(143.6)

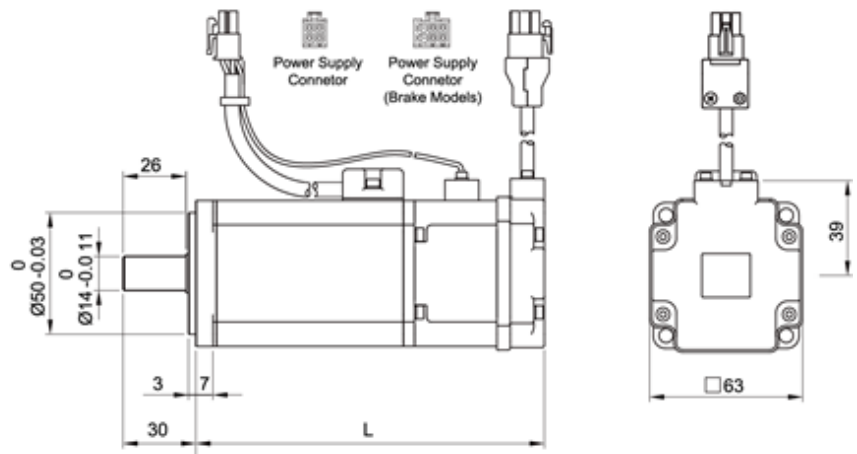
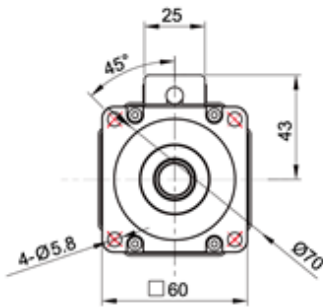

【SMH-L075】

Model	L
SMH-L075(B)	127.5(163.5)

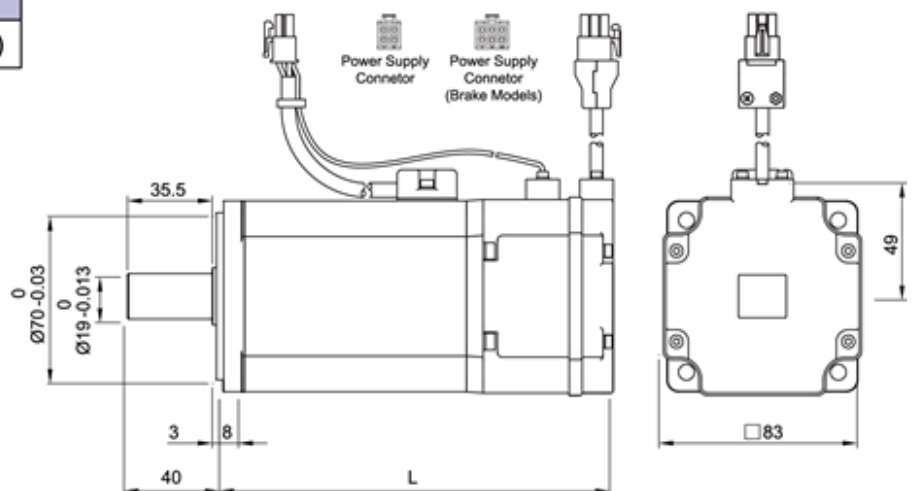
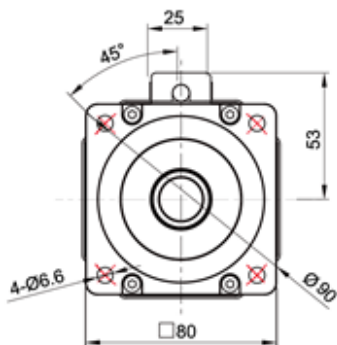

12.6 Permissible shaft load of low inertia motor

Motor type	SMH-L0100(B)	SMH-L0200(B)	SMH-L0400(B)	SMH-L0750(B)
L (mm)	25	30	30	40
Permissible load in radial direction N(kgf)	68.6(7)	245(25)	245(25)	392(40)
Permissible load in axial direction N(kgf)	39.2(4)	98(10)	98(10)	147(15)

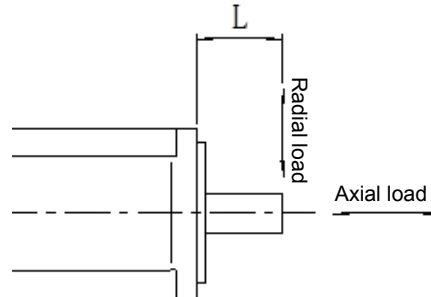

12.7 Dimensions of medium inertia motors

【SMH-M050】

Model	L
SMH-M050(B)	124(158)

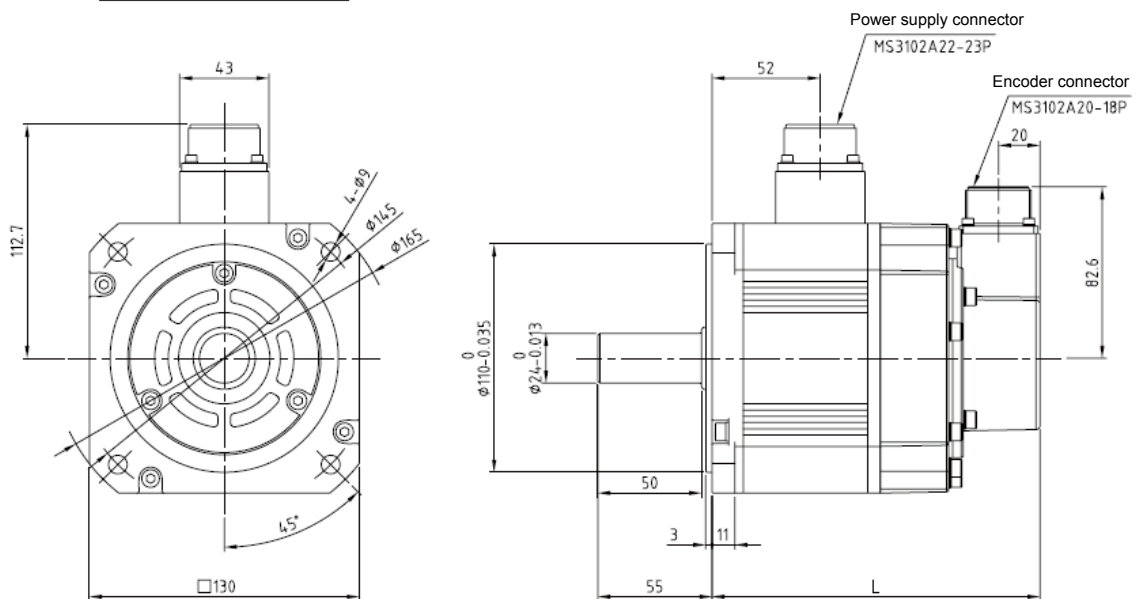

【SMH-M100】

Model	L
SMH-M100(B)	150(184)

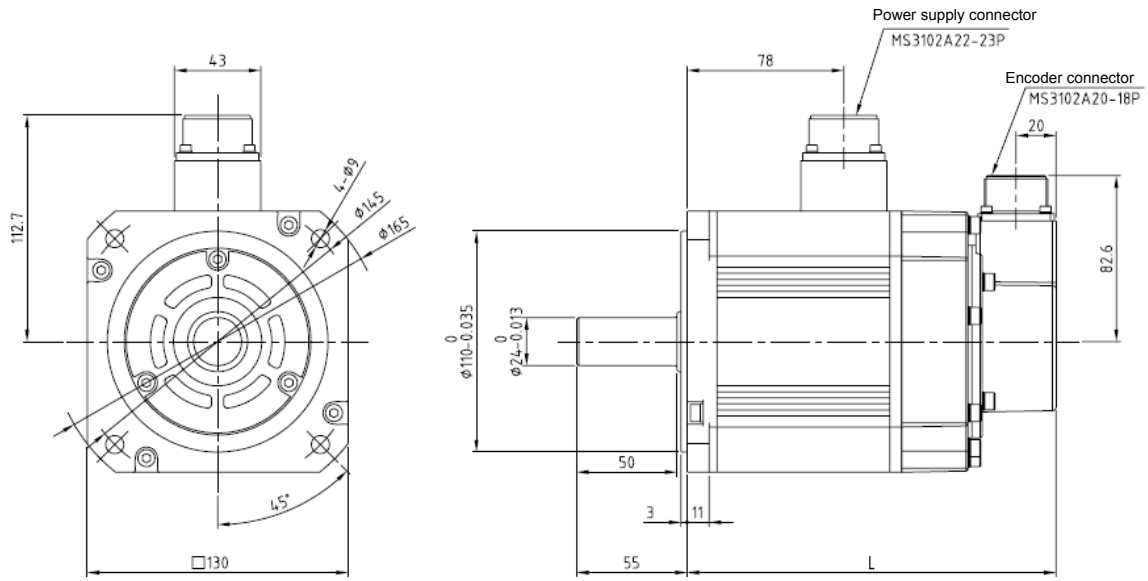

【SMH-M150】

Model	L
SMH-M150(B)	176(210)

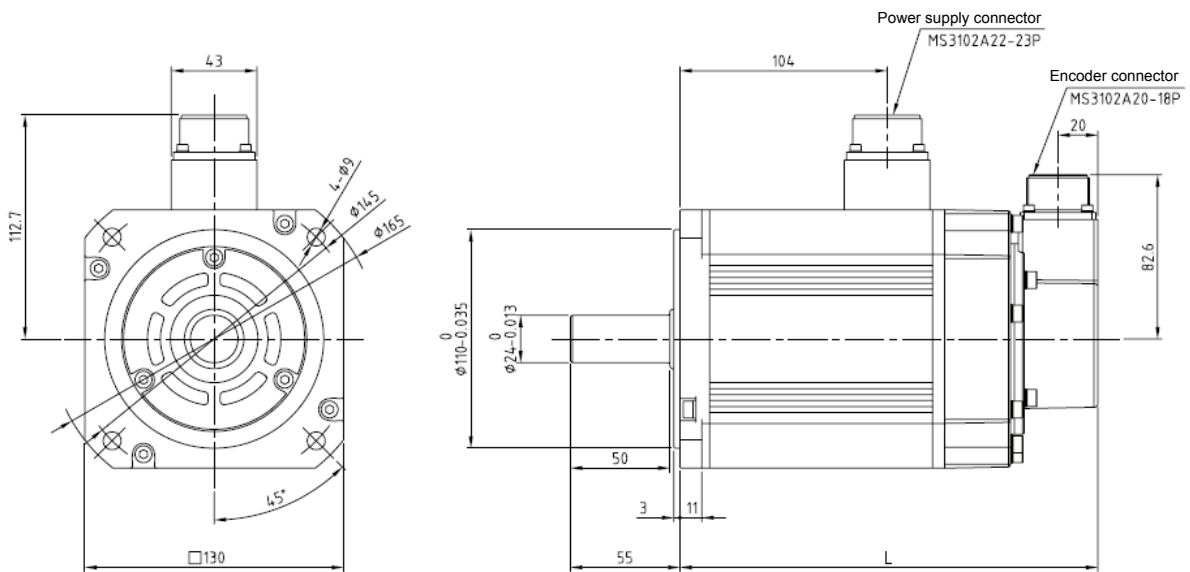

【SMH-M200】

Model	L
SMH-M200(B)	149(199)

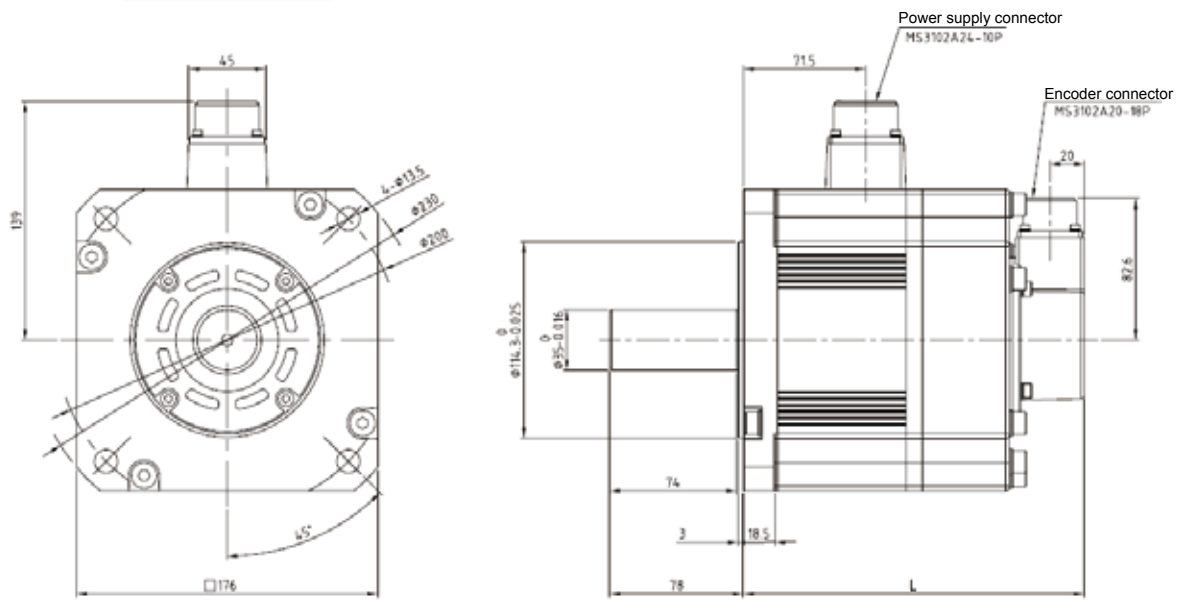

【SMH-M350】

Model	L
SMH-M350(B)	180(230)

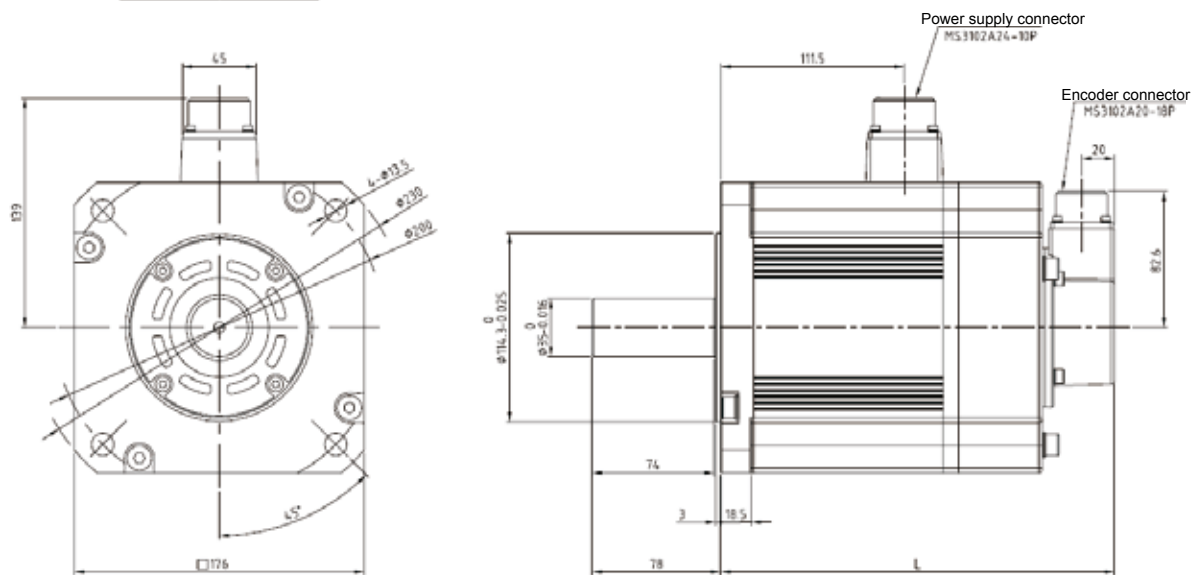

【SMH-M500】

Model	L
SMH-M500(B)	189(239)

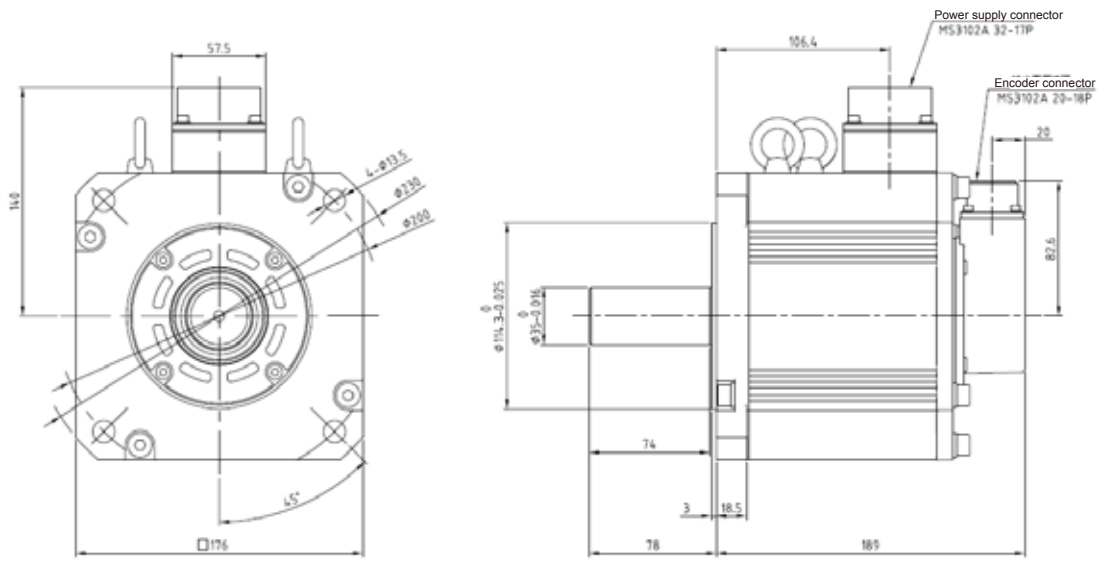

*The following is the drawing with brake

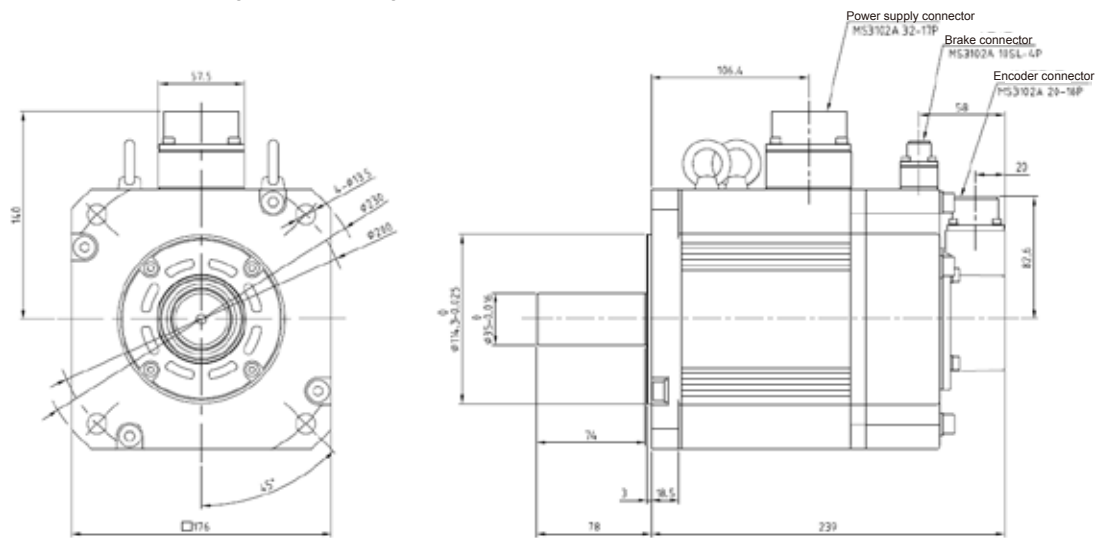

【SMH-M700】

Model	L
SMH-M700(B)	229(279)

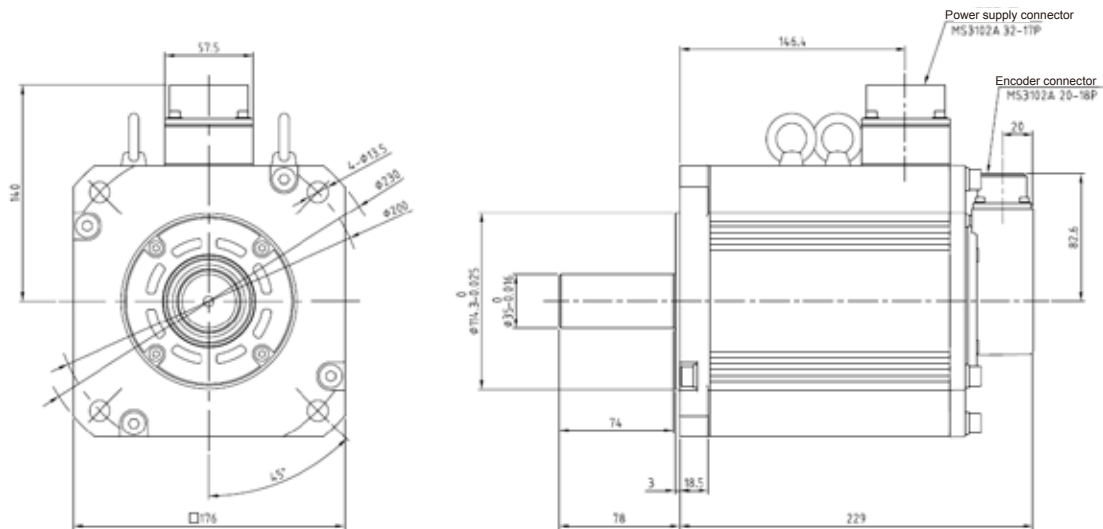

*The following is the drawing with brake

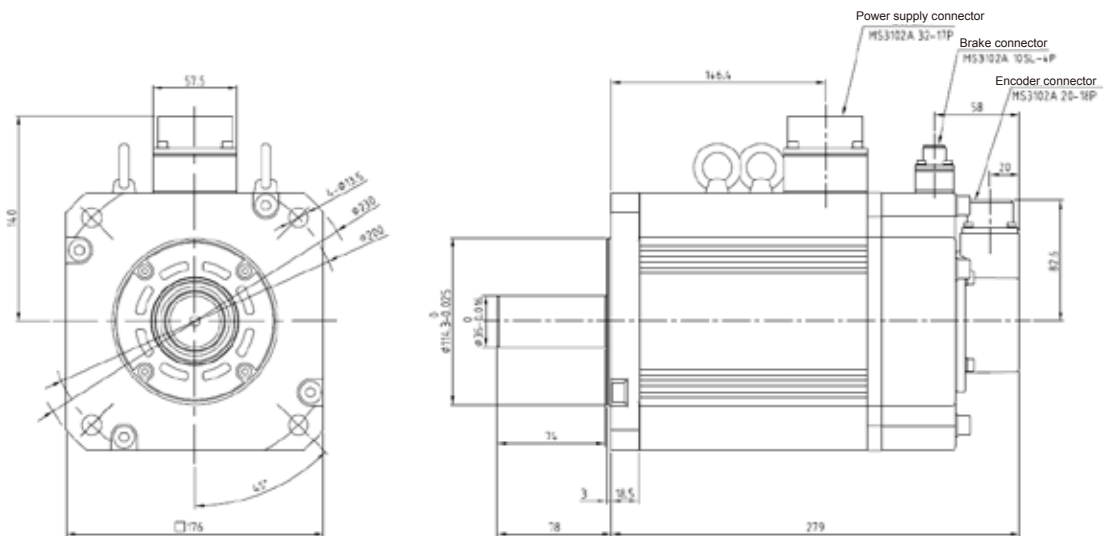

- The size varies according to the finished motor design, including with electromagnetic brake size too.
- unit [mm]
- Dimensions of servo motors may be revised without prior notice.

12.8 Permissible shaft load of medium inertia motor

Motor type	SMH-M050(B)	SMH-M100(B)	SMH-M150(B)	SMH-M200(B)	SMH-M350(B)	SMH-M500(B)	SMH-M700(B)
L (mm)	55	55	55	78	78	78	78
Permissible load in radial direction N(kgf)	490(50)	490(50)	490(50)	980(100)	980(100)	980(100)	980(100)
Permissible load in axial direction N(kgf)	196(20)	196(20)	196(20)	392(40)	392(40)	392(40)	392(40)

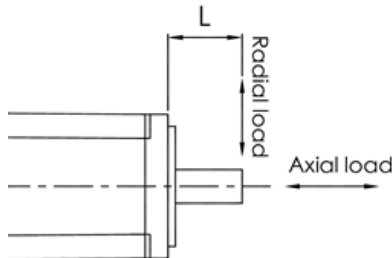

12.9 Precision of motor shaft

Precision of motor shaft varies with the dimensions such as right angle grade, deflection degree, concentric grade, etc. The table below provides more details.

Precision (mm)		Motor frame size		
		□100 or less	□130	□176
Right angle grade of frame to shaft	a	0.05	0.06	0.08
Shaft deflection degree	b	0.02	0.02	0.03
Concentric grade of outer diameter to shaft	c	0.04	0.04	0.06

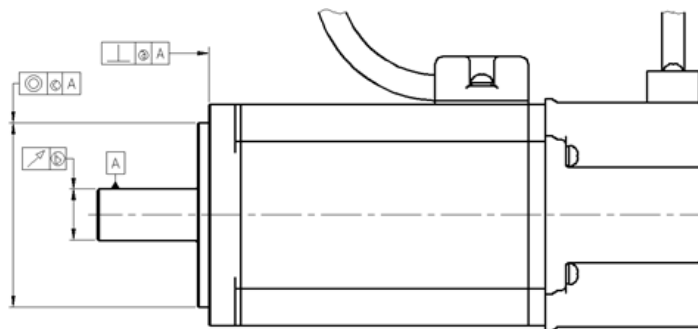

12.10 Electromagnetic compatible filter (EMC Filter)

If the drive and motor need to comply with EMC rules, filters are recommended.

Drive	Power	Recommended filter
SDH-010A2	100W	FN3258-7-45
SDH-020A2	200W	
SDH-040A2	400W	
SDH-050A2	500W	
SDH-075A2	750W	FN3258-16-45
SDH-100A2	1KW	
SDH-150A2	1.5KW	FN3258-30-47
SDH-200A2	2KW	
SDH-350A2	3.5KW	
SDH-500A2	5KW	
SDH-700A2	7KW	

- The filter is option.
- As an operating servo drive or motor interfere with peripheral equipment by radiation or conduction, it is recommended to use the filter. Here is a wiring diagram for the filter application.

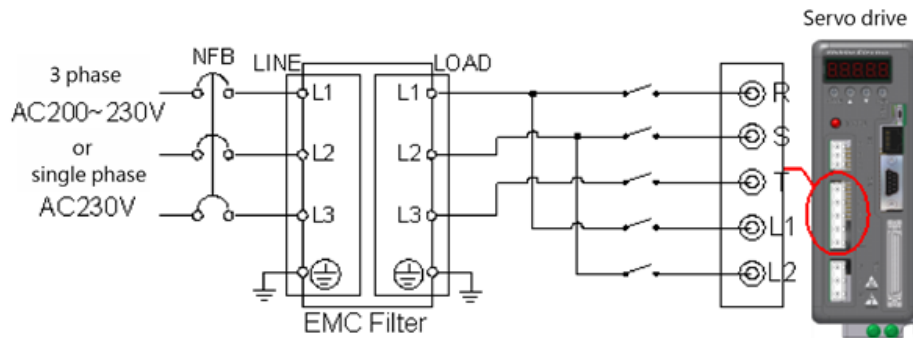

- If the single phase power is applied, T terminal of drive is idle.
- EMC Filter should be well grounded

12.11 Power factor improving DC reactor

Using the power factor improving DC reactor, the following effects can be obtained.

- The power factor improving DC reactor increases the form factor of the servo drive input current to improve the power factor. As compared to the power factor improving AC reactor (FR-BAL), it can decrease the loss.
- It can decrease the power supply capacity.
- It can reduce the input side harmonics.

When connecting the power factor improving DC reactor to the servo drive, always disconnect the wiring across P-P1. If it remains connected, the effect of the power factor improving DC reactor is not produced.

When used, the power factor improving DC reactor generates heat. To release heat, therefore, leave a 10cm or more clearance at each of the top and bottom, and a 5cm or more clearance on each side.

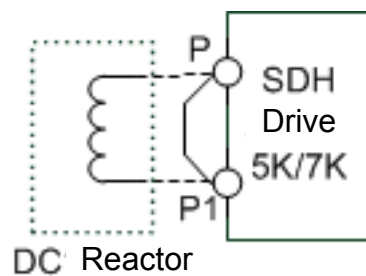

Drive	Power	Recommended filter
SDH-500A2	5KW	LNKBEL5R5K
SDH-700A2	7KW	LNKBEL7R5K

- The Power factor improving DC reactor is option.

13. Motor characteristic

13.1 Speed-torque curves of low inertia motor

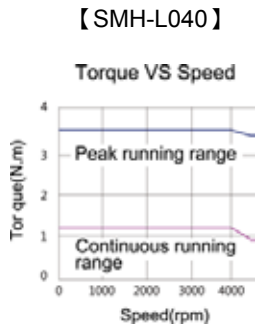
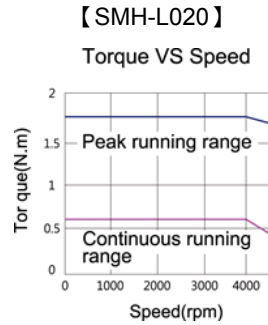
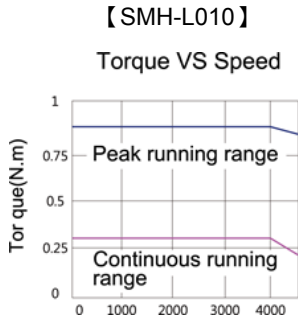

- These characteristic curves are plotted with AC 3 ϕ 200~230V power applied

13.2 Speed-torque curves of medium inertia motor

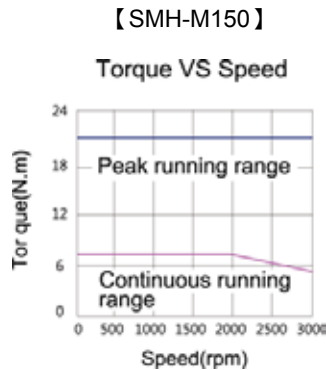
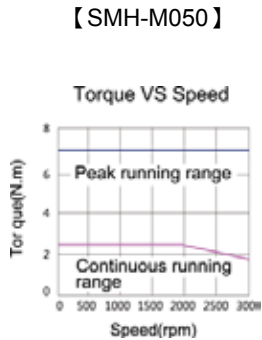

- These characteristic curves are plotted with AC 3 ϕ 200~230V power applied

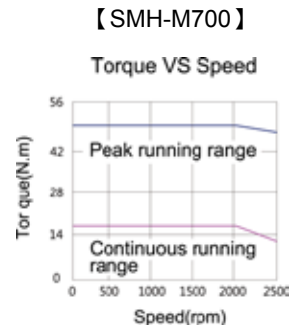
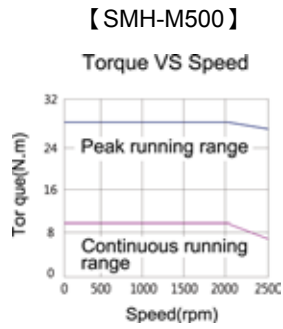
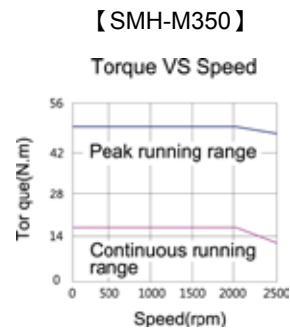
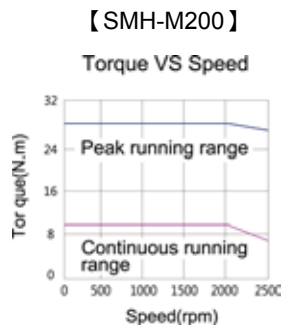

- These characteristic curves are plotted with AC 3φ 200~230V power applied

13.3 Overload protection

Overload protection is to prevent motor from damage during instantaneous over rated operation. Some cases are described as follows.

- (1) The ratio of load inertia to motor shaft is too large.
 - (2) During acceleration or deceleration process, the time constant is set too small.
 - (3) The operating time which torque generated is over rated torque is too long.
 - (4) Mechanism vibration occurred due to improper gain is ignored but the motor is still performed.
 - (5) Wrong connection between drive and motor, or the encoder is faulty.
- If case mentioned above met, the permissible operating time is plotted below.

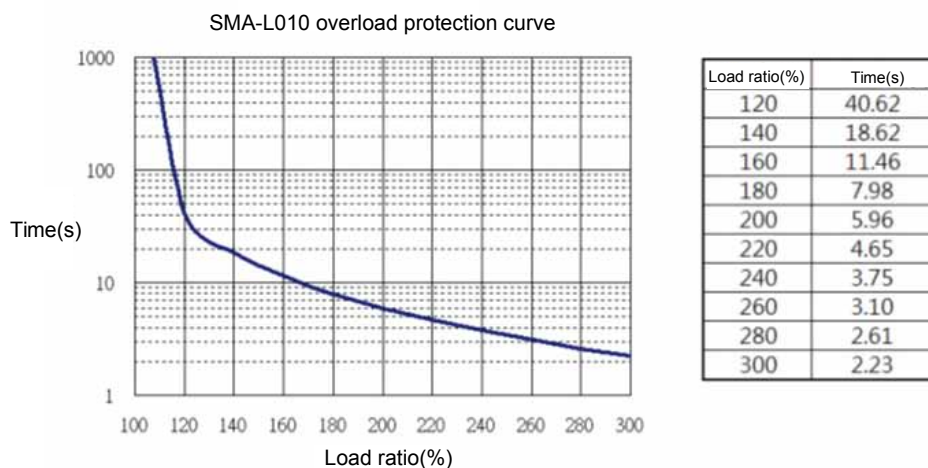

As load torque is 300% · operating time is 2.23S.

SMA-L020-L075 overload protection curve

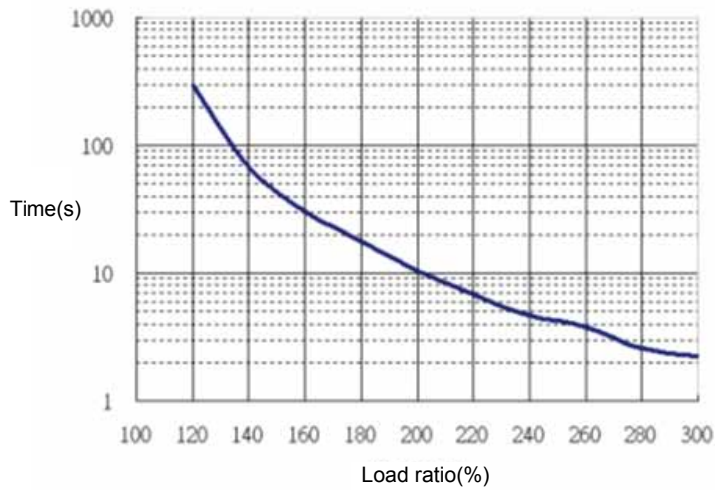

Load ratio(%)	Time(s)
120	298.67
140	67.75
160	30.25
180	17.54
200	10.49
220	6.85
240	4.96
260	3.78
280	2.61
300	2.23

As load torque is 300% · operating time is 2.23S.

SMA-L050/L100 overload protection curve

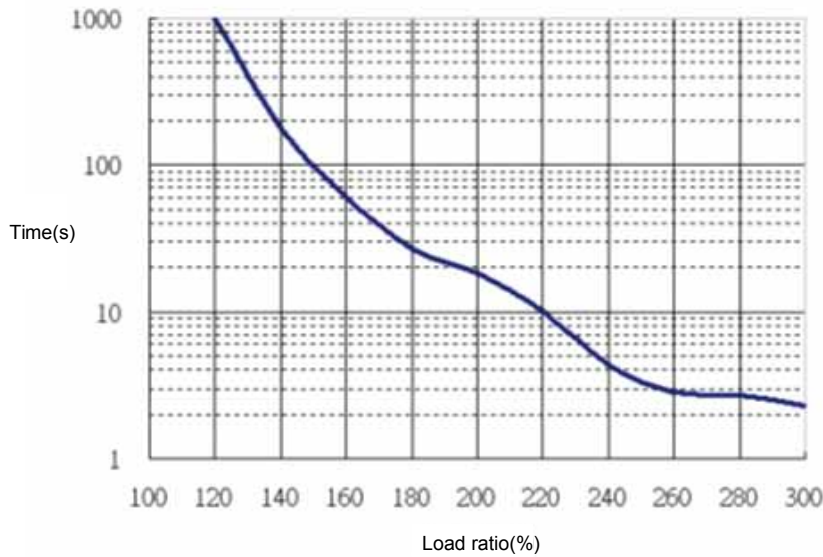

Load ratio(%)	Time(s)
120	1000.00
140	176.33
160	60.67
180	27.00
200	18.20
220	10.24
240	4.34
260	2.80
280	2.67
300	2.28

As load torque is 300% · operating time is 2.28S.

14. Absolute servo system

For configuring the absolute system, there are servo drive, absolute servo motor and absolute encoder cable(including battery case).

The absolute position detection system does not detect and save the position by programming controller. It detects the absolute position of the machine and keeps it battery-backed, independently of whether the power is on or off. Therefore, once home position return is made at the time of machine installation, home position return is not needed when power is switched on thereafter.

Even at a power failure or a malfunction, the system can be easily restored

If the drive is settled absolute system parameter, it's necessary to use absolute motor. When incremental motor is used to activate the absolute function, AL. 24 alarm will occur.

Absolute servo motor model explanation:

SMH-□□□□R□□M□□
 M : Absolute servo motor

CAUTION	If an [absolute position erase alarm] or an [absolute position counter warning] has occurred, always perform home position setting again.
	Keep the battery in the battery case before use to prevent unpredictable factors such as the battery short circuit.
	When using an absolute servo motor, please make sure that the motor speed is below 50rpm when power on.
	When drive is powered off, please keep speed be below 50rpm in battery mode.
POINT	If battery was removed, the absolute position data is erased from the encoder, always execute home position setting before operation.

Restrictions :

The system cannot be configured under the following conditions.

- (1) Speed control mode and torque control mode
- (2) Control switch-over mode (position/speed, speed/torque, and torque/position)
- (3) Stroke-less coordinate system, e.g. rotary shaft, infinitely long positioning
- (4) Changing electronic gear after home position setting.
- (5) Using alarm code output.

Battery change :

- (1) Please change battery to avoid losing data when the drive display alarm AL.2D
- (2) When the voltage of battery is under 2.45V that cause the motor position lost ,please change battery and do homing.

CAUTION	It is recommended to change battery at power on situation of drive , or it will lost absolute position data.
---------	--

Initialization

In the first use of absolute system, due to the absolute coordinate system has not been set, so the drive will occur first alarm AL. 2C, until after the absolute coordinate system is set to disappear. If due to lack of battery power loss caused by the coordinate system, drive different police AL also occur 2C; After replacing the battery first boot, different police AL.2A drive will happen again reboot can be lifted. In the absolute system, there are certain restrictions position when the motor is running laps over the range of -32768 to +32767 circle occurs first alarm AL. 29.

- (1)The fault code, AL.2C can be cleared by resetting the coordinate system If the drive do homing in Pr mode, absolute coordinate system will be cleared after this operation.
- (2)When the servo system is power on again, the host controller can get the motor coordinate position via communication with DI/DO.

Pulse number

The number range for motor turns is from -32768 to 32767. The fault code, AL.29 will appear when exceeding this counting range. In according to the type of motor encoder, motor pulse value of one turn is shown in the following table.

Encoder type (PA43)	pulse value
PA43 = 0	1048576 (20bit)
PA43 = 1	4194304 (22bit)
PA43 = 2	8388608 (23bit)

The turn and pulse of absolute servo system can get the motor coordinate position via communication with DI/DO. Please see the following as example.

Take PA43=1 (22bit encoder) for example.

In addition, there are 1280000 pulses (0~1279999) in one rotation. Please pay attention on its direction. The communication or digital inputs/digital outputs can be used to read it.

$$\text{Pulse number for the distance} = r(\text{turn}) \times 4194304 + \text{pulse number within one turn (0~4194304)}$$

If the motor rotated 10 turns and 50000 pulses, the total pulses will be as following formula.

$$\begin{aligned} \text{Total pulses} &= 10 \times 4194304 + 50000 \\ &= 41993040 \text{ (pulse)} \end{aligned}$$

Reading absolute position

Please refer to status monitoring communication parameter table of section 9.4 about reading data. It is suggested to use " Motor feedback pulse (before electric gear)". Here is the simple table for reference.

Position	Items	Data Length
0x0000	Motor feedback pulse (after electric gear) [pulse]	2word
0x0024	Motor feedback pulse (before electric gear) [pulse]	2word

The drive will update the current encoder status and absolute position of motor by writing PA30. When PA30 = 1, errors will not be cleared when read position data. If PA30 = 2 o'clock, errors will be cleared when read position data.

When the servo motor is motionless, it will do tiny position correction. In order to avoid absolute coordinate values different from the actual position, users can set coordinate and clear position error. After the drive has been updated encoder status and absolute position of motor, the drive will set PA30 back to 0 automatically, that means parameter data can be read by the host controller.

If the encoder status displays " absolute position lost" or "absolute turn overflow", the absolute position is invalid. Please do initialize absolute coordinate system or do home returning again.

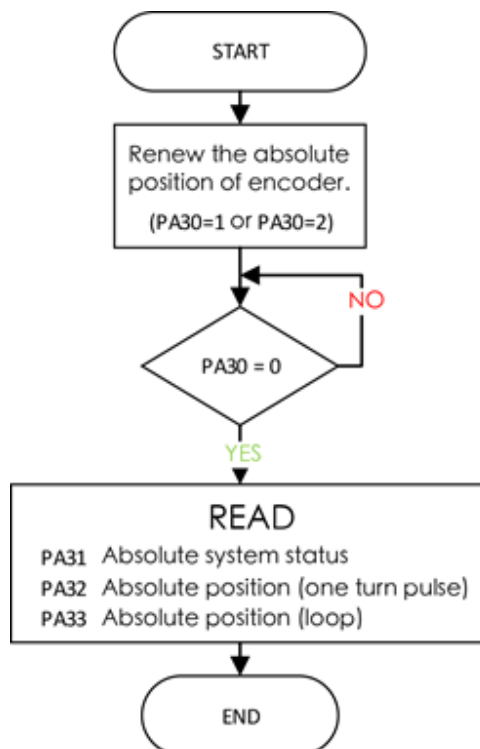

14.1 Mitsubishi Absolute Position Detection System

14.1.1 Signal explanation :

When the absolute position data is transferred, the signals of connector CN1 change as described in this section.

Signal name	Code	CN1 connector pin No.	Function/Application	I/O
ABS transfer mode	ABSM	plan able	While ABSM is on, the servo amplifier is in the ABS transfer mode which has the functions of ABSR、ABST、ABSB0、ABSB1.	DI-x
ABS request	ABSR	17	Turn on ABSR to request the absolute position data in the ABS transfer mode.	DI-4 (regular)
ABS transmission data Bit 0	ABSB0	43	Indicates the lower bit of the absolute position data (2 bits).	DO-3 (regular)
ABS transmission data Bit 1	ABSB1	44	Indicates the upper bit of the absolute position data (2 bits).	DO-4 (regular)
ABS transmission data ready	ABST	42	Indicates that the data to be sent is being prepared in the ABS transfer mode. At the completion of the ready state, ABST turns on.	DO-2 (regular)
ABS Home position setting	ABSC	plan able	When ABSC is turned on, the home position data is cleared.	DI-x
ABS position lost	ABSV	plan able	When absolute position is lost ,ABSV is turned on .	DO-x

Please refer to the following standard connection for example.

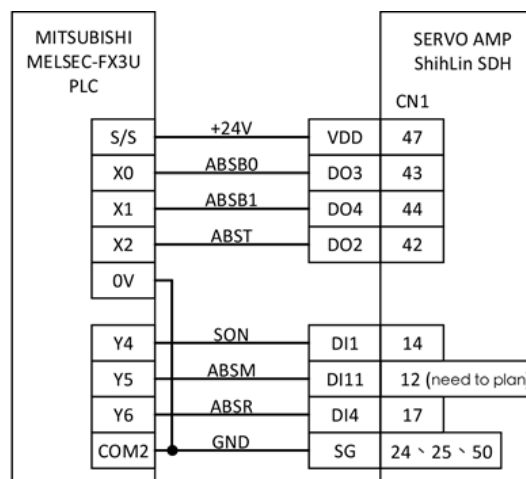

14.1.2 Startup procedure :

(1) Absolute motor and battery installation.

(2) Parameter setting

Set "1" in [Pr. PA28] which is setting absolute system.

Set "1" in [Pr. PA34] and switch power off which is setting Mitsubishi absolute position detection system. Then on and parameter settings become effective.

(3)[AL.2A absolute encoder error 1]Reset alarm

After changing battery, [AL.2A absolute encoder error 1] occurs at first power-on. Turn off the power, then on to reset the alarm.

(4)Absolute position lost[AL.2C absolute encoder error 3] Reset alarm

After connecting the encoder cable, [AL.2C absolute encoder error 3] occurs at first power-on. Please set "1" in [Pr. PA29] or initialize to reset alarm.

(5)Confirmation of absolute position data transfer

When SON is turned on, the absolute position data is transferred to the programmable controller.

Transferring the proper absolute position data will trigger the followings

- (a) RD (Ready) turns on.
- (b) The ABST data ready contact of programmable controller turns on.
- (c) When [AL. E5 ABS time-out warning] error occurs, refer to chapter 11 and take corrective action.

(6)Home position setting

The home position must be set if.

- (a) System set-up is performed;
- (b) The servo amplifier has been changed;
- (c) The servo motor has been changed; or
- (d) Absolute position lost [AL.2C absolute encoder error 3] occurred.

In the absolute position detection system, the absolute position coordinates are made up by making home position setting at the time of system set-up. The motor shaft may operate unexpectedly if positioning operation is performed without home position setting.

14.1.3 Absolute position data transfer protocol :

(1)Data transfer procedure

Each time SON is turned on (when the power is switched on for example), the programmable controller reads the position data (present position) of the servo amplifier.

POINT	After switching on ABSM, turn on SON. When the ABS transfer mode is off, turning on SON does not switch on the base circuit.
-------	--

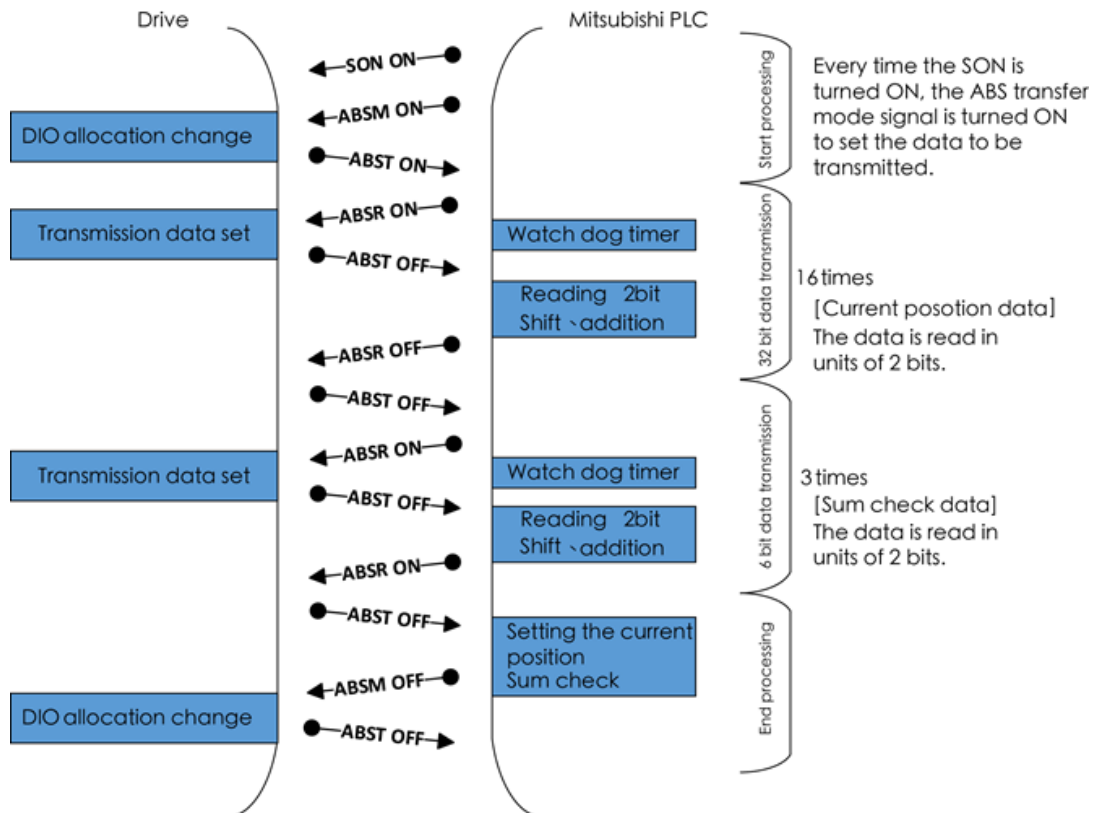

(2)Transfer method

In the absolute position detection system, every time SON is turned on, ABSM should always be turned on to read the current position in the servo drive to the controller. The servo drive transmits to the controller the current position latched when ABSM switches from off to on. At the same time, this data is set as a position command value inside the servo drive. Unless ABSM (ABS transfer mode) is turned on, the base circuit cannot be turned on.

(a) Timing chart

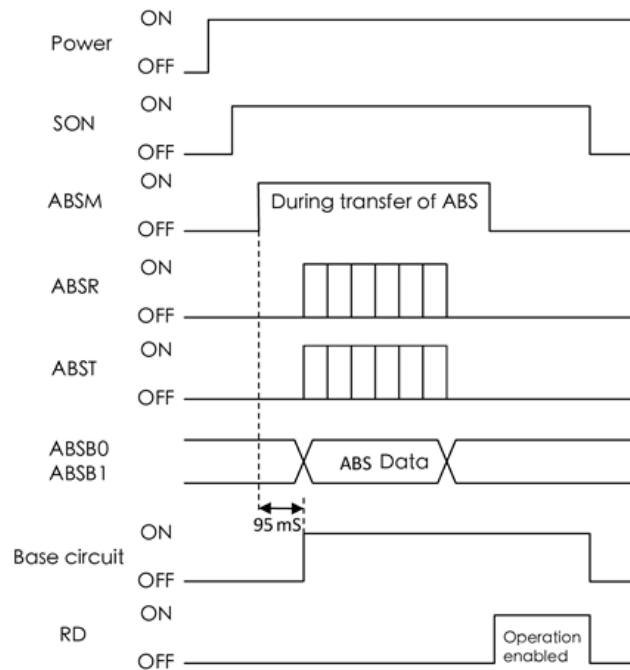

(1)After the absolute position data is transmitted, RD turns on by ABSM-off. When RD is on, ABSM on is not received.

(2)Even if SON is turned on before ABSM is turned on, the base circuit is not turned on until ABSM is turned on.

(3)If a servo alarm has occurred, ABSM is not received. ABSM allows data transmission even while a servo warning is occurring. If ABSM is turned off during the ABS transfer mode, the ABS transfer mode is interrupted and.

[AL. 17 ABS time-out warning] occurs.

If SON is turned off, RES is turned on, and EMG is turned off during the ABS transfer mode, [AL. ABS time-out warning] occurs.

(4)Note that if ABSM is turned on for a purpose other than absolute position data transmission, the output signals will be assigned the functions of absolute position data transmission.

CN1 Pin No.	Output signal	
	ABSM OFF	ABSM ON
43	WNG Warning / CMDOK Positioning completion	ABS transmission data bit0
44	TLC During torque limit control	ABS transmission data bit1
42	ZSP Zero speed detection	ABS transmission data ready

(5)ABSM is not accepted while the base circuit is on. For re-transferring, turn off SON signal and keep the base circuit in the off state for 20 ms or longer.

(b) Detailed description of absolute position data transfer

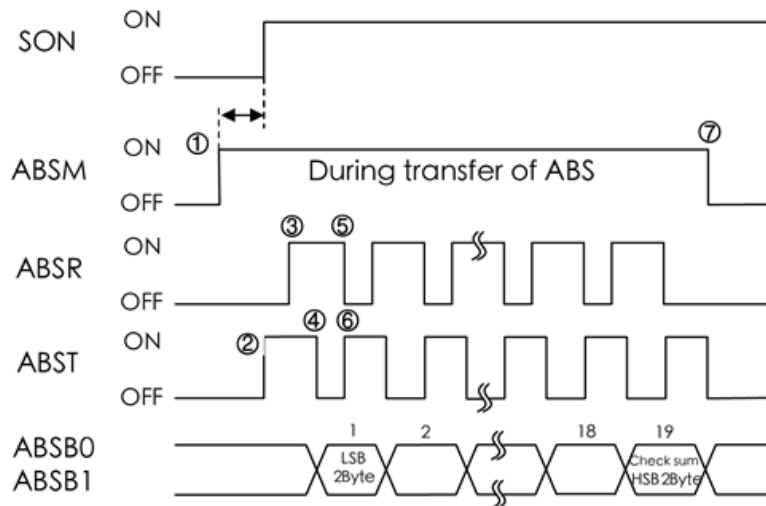

After turn ABSM on, if do not switch SON on within 1 s, will occur but have no influence about transmission. If users want to clear ABS time-out alarm, just switch SON on. See the followings for details.

- (1)The programmable controller turns on ABSM and SON at the leading edge of the internal servo on.
- (2)In response to ABS transfer mode, the servo detects and calculates the absolute position and turns on ABST to notify the programmable controller that the servo is ready for data transmission.
- (3)After acknowledging that ABST is turned on, the programmable controller will turn on ABSR.
- (4)In response to ABSR, the servo outputs the lower 2 bits of the absolute position data and ABST in the off state.
- (5)After acknowledging that ABST has been turned off, which implies that 2 bits of the absolute position data have been transmitted, the programmable controller reads the lower 2 bits of the absolute position data and then turns off ABSR.
- (6)The servo turns on ABST so that it can respond to the next request. Steps 3) to 6) are repeated until 32-bit data and the 6-bit checksum have been transmitted.
- (7)After receiving of the checksum, the programmable controller confirms that the 19th ABST is turned on, and then turns off ABSM. If ABSM is turned off during data transmission, ABSM is interrupted and the [AL. 17 ABS time-out warning] occurs.

(c)Checksum

The checksum is the code which is used by the programmable controller to check for errors in the received absolute position data. The 6-bit checksum is transmitted following the 32-bit absolute position data. Every time the programmable controller receives 2 bits of absolute position data, it adds the data to obtain the sum of the received data. The checksum is 6-bit data.

(Example)ABS data : -30000 (FFFF8AD0) · the checksum of is 22H °

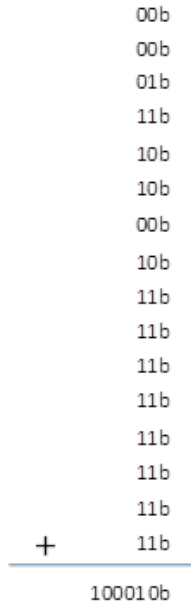

(3) Transmission error :

[AL.17 ABS time-out warning]

In the ABS transfer mode, the servo drive processes time-out below, and displays [AL. 17] when a time-out error occurs.

(1)ABSR request off-time time-out check

If the ABS request signal is not turned on by the programmable controller within 5 s after ABST is turned on, this is regarded as a transmission error and [AL. 17 ABS time-out warning] is output.

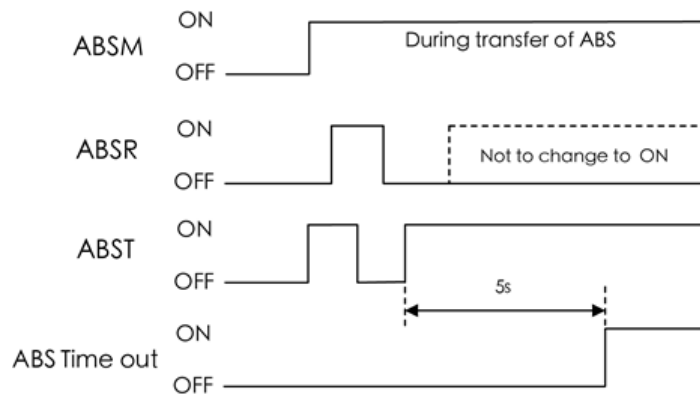

(2) ABSR request on-time time-out check

If the ABSR is not turned off by the programmable controller within 5 s after ABST is turned off, this is regarded as the transmission error and [AL. 17 ABS time-out warning] is output.

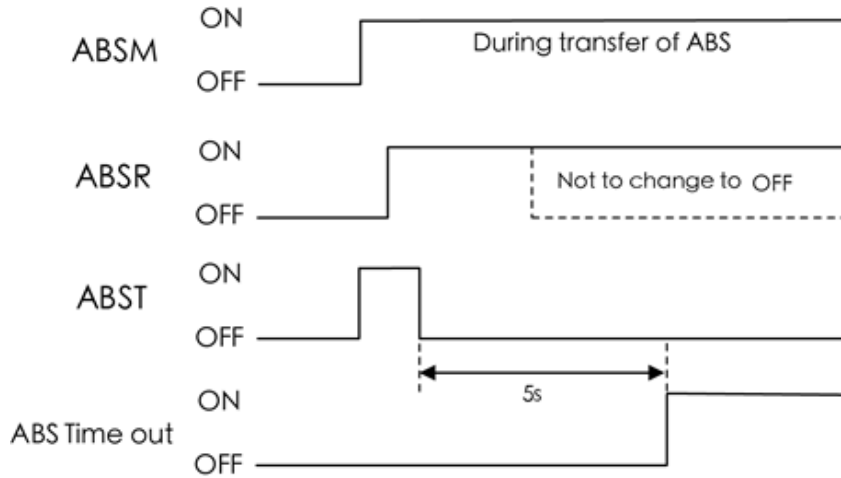

(3) ABSM transfer mode finish-time time-out check

If ABSM is not turned off within 5 s after the last ABS transmission data ready is turned on, it is regarded as the transmission error and the [AL. 17 ABS time-out warning] is output.

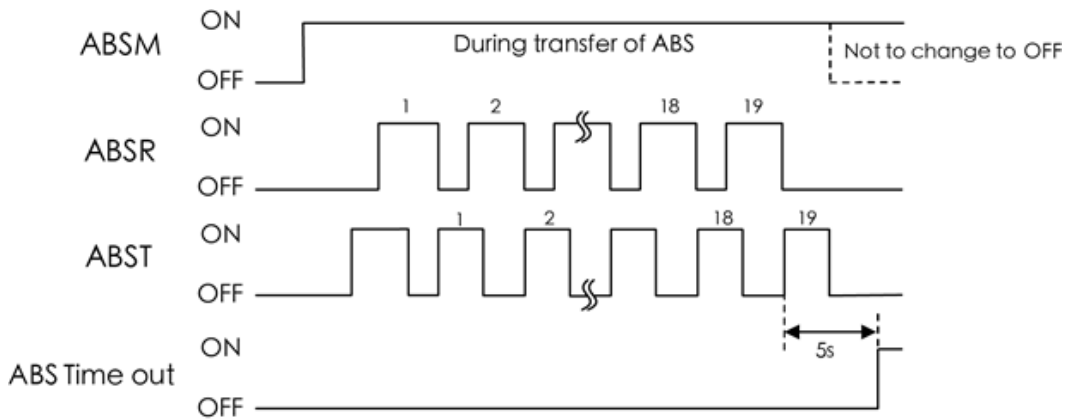

(4) ABSM-off check during the ABS transfer

When the ABSM is turned on to start transferring and then the ABS transfer mode is turned off before the 19th ABS transmission data ready is turned on, [AL. 17 ABS time-out warning] occurs, regarding it as a transfer error.

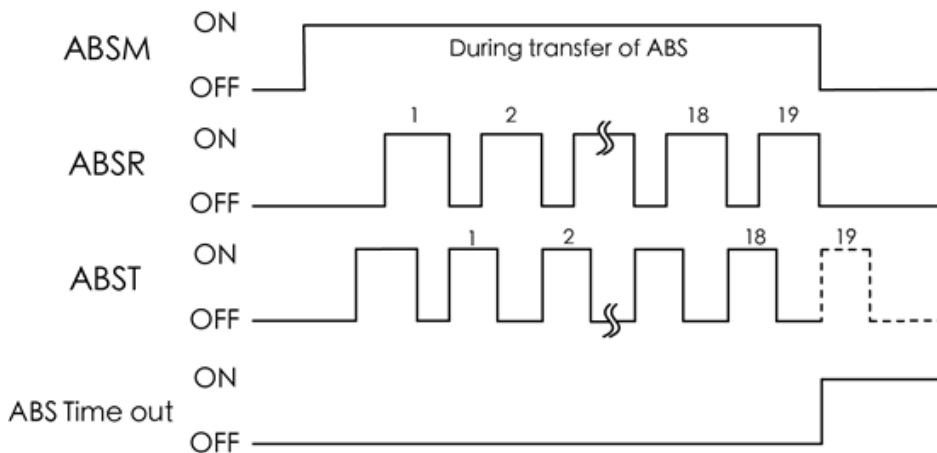

(5) SON off, RES on, and EM2 off check during the ABS transfer

When the ABS transfer mode is turned on to start transferring and then SON is turned off, RES is turned on, or EM2 is turned on before the 19th ABST is turned on, [AL. 17 ABS time-out warning] occurs, regarding it as a transfer error.

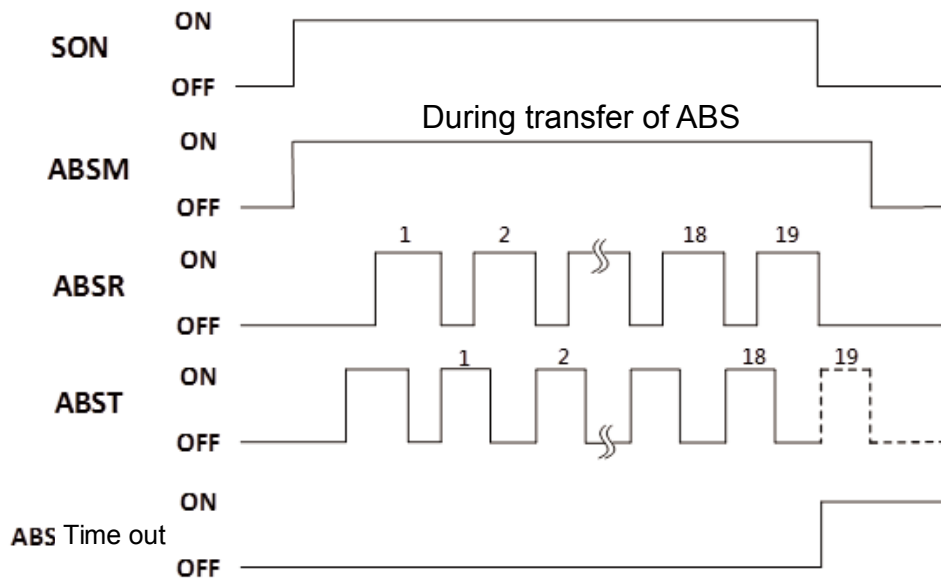

Checksum error

If the checksum error occurs, the programmable controller should retry transmission of the absolute position data.

Using the ladder check program of the programmable controller, turn off ABSM. After a lapse of 10 ms or longer, turn off SON (off time should be longer than 20 ms) and then turn it on again. If the absolute position data transmission fails even after retry, process the ABS checksum error.

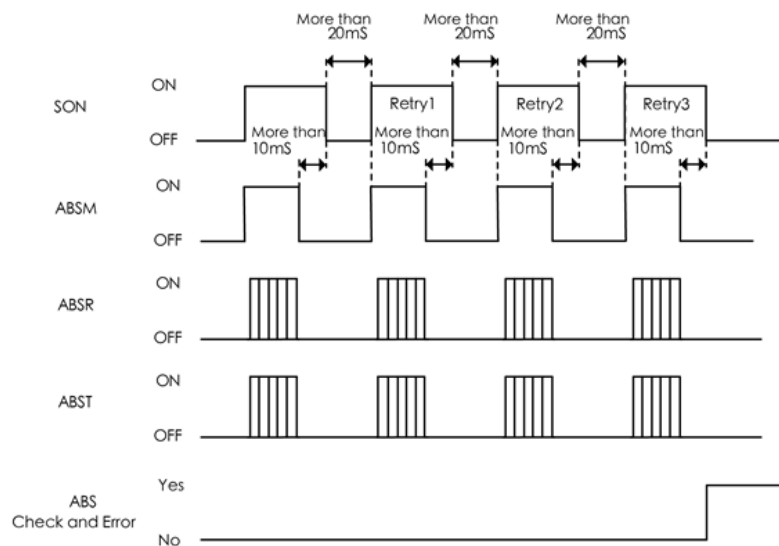

At the time of alarm reset

If an alarm occurs, turn off SON by detecting ALM. If an alarm has occurred, ABSM cannot be accepted. In the reset state, ABSM can be input.

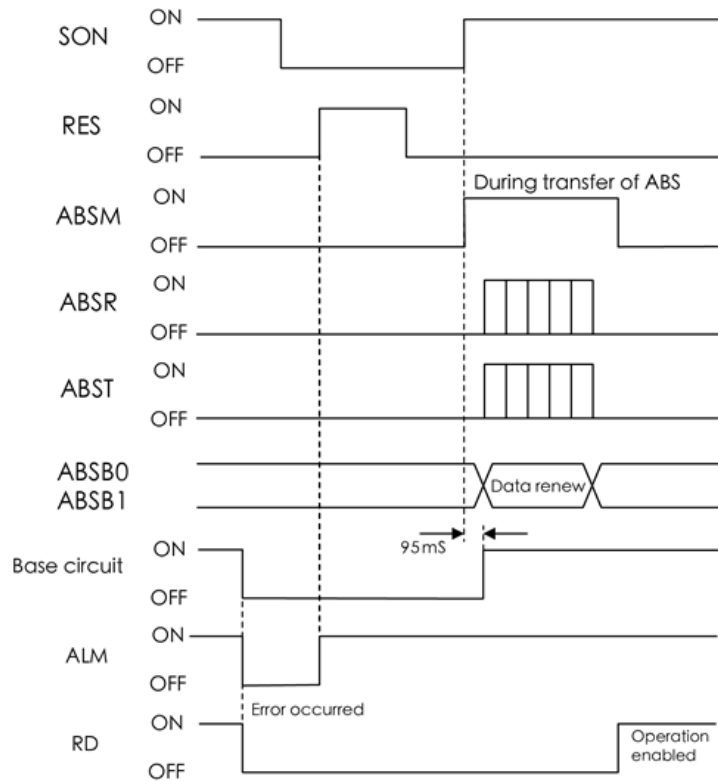

Home position setting

Point	Never make home position setting during command operation or servo motor rotation. It may cause home position shift.
-------	--

Move the machine to the position where the home position is to be set by performing manual operation such as JOG operation. When CR is on for longer than 20 ms, the stop position is stored into the nonvolatile memory as the home position absolute position data. When the servo on, set CR to on after confirming that INP is on. The number of home position setting times is limited to 100,000 times.

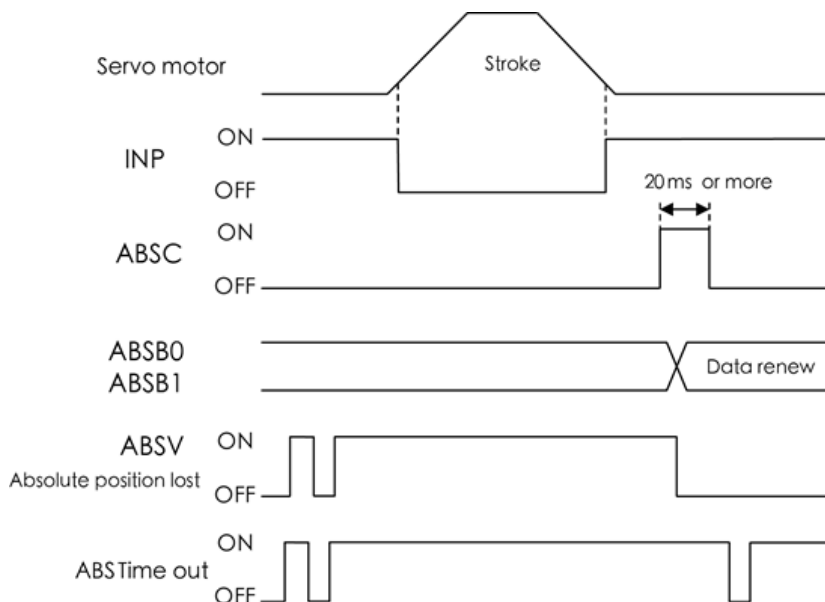

14.2 Delta Absolute Position Detection System

14.2.1 Signal explanation :

When absolute position data transfers, the signal of terminal CN1 will be changed.

Signal name	Code	CN1 pin No.	Function/Application	I/O
ABS transfer mode enable	ABSE	Plan able	When DI.ABSE is ON, it is in ABS mode. DI.ABSQ, DI.ABSC, DI.ABSR, DI.ABSD and DI.ABSC are enabled.	DI-x
ABS Signal request	ABSQ	17	During I/O transmission, Handshaking signal will be sent to the servo drive by the controller. When DI.ABSQ is OFF, it means the controller issues Request ; DI.ABSQ is ON means the controller has already received ABSD signal. When DI.ABSE is ON, this DI is enabled.	DI-4 (Fix)
ABS Signal ready	ABSR	43	DO.ABSR is OFF means the Request sent by ABSQ has been received. DO.ABSR is ON means the data that is outputted by ABSD is valid. When DI.ABSE is ON, this DO is enabled.	DO-3 (Fix)
ABS Data content	ABSD	44	Position data of ABS is outputted. The data is valid when ABSR is ON. When DI.ABSE is ON, this DO is enabled.	DO-4 (Fix)
ABS transmission error	ABSW	Plan able	Warning of absolute encoder.	DO-x
Home position setting	ABSC	Plan able	When DI.ABSC is ON, multi-turn data stored in absolute encoder will be cleared. When DI.ABSE is ON, this function is enabled.	DI-x

Please refer to example below for wiring.

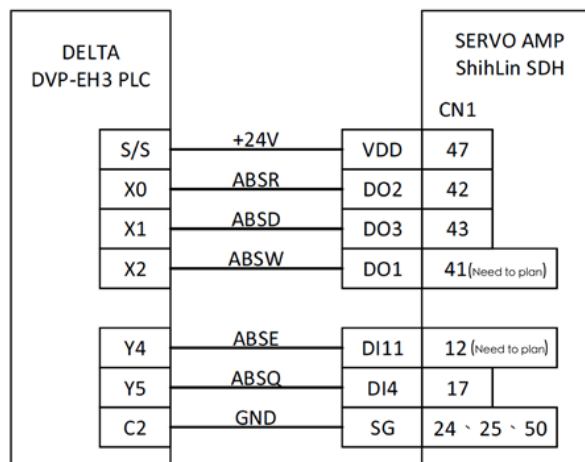

14.2.2 Start procedure :

- (1) Install absolute motor and battery.
- (2) Parameter setting
Set PA28 to "1" and becomes to absolute system.
Set PA34 to "□□0" and restart to set delta absolute position detection system.
- (3) [AL.2A absolute encoder error1] alarm clear
When replacing the battery and power on for the first time, there will be "AL.2A absolute encoder error 1" alarm, please turn the power OFF to On to clear alarm.
- (4) Absolute position lost [AL.2C absolute encoder error 3] alarm clear
The first power on in the absolute system, there will be "AL.2C absolute encoder error 3" alarm, please set PA29 to "1" or perform initialization coordinates to clear alarm.

(5)Home returning

Please perform home setting as following conditions.

- (a) set up absolute system.
- (b) Replace the servo drive.
- (c) Replace the servo motor.
- (d) When absolute position lost occurs [AL.2C absolute encoder error 3]alarm

When setting the absolute position system, users can establish absolute coordinate position by home setting. With no home setting and operate the motor, an unexpected action will occur.

14.2.3 Use Digital Inputs/Outputs to Initialize an Absolute System :

Initialize an absolute system by DI/DO method or writing PA29 parameter. Please do homing to initialize absolute coordinates in Pr mode.

Move the motor to home place, enable digital input, ABSE, then enable digital input, ABSC from OFF to ON, and the system will start to initialization. The pulse number will be set to zero. Please refer to Figure below for the signal controlling chart.

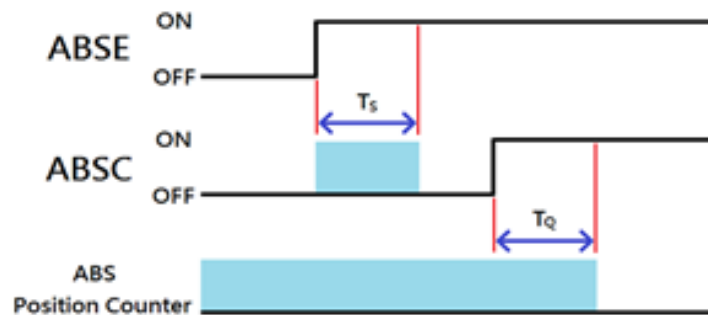

	Ts(ms)	Tq(ms)
Min	PD15 + 2	
Max	PD15 + 10	

The descriptions for the timing :

1.When the host controller switches ABSE from OFF to ON, a period of time Ts have to be waited for the next step to process.

2.After waiting time Ts, the host controller now can enable the ABSC from OFF to ON and hold the signal for TQ to reset the coordinate system where pulse number will be zero.

14.2.4 Use Parameters to Initialize an Absolute System

Initialize an absolute system by panel operation or writing PA29 parameter. When 1 was written into PA29, absolute coordinates will initialize immediately. Please do homing to initialize absolute coordinates in Pr mode.

Bit79 ~ Bit64	Bit63 ~ Bit32	Bit31 ~ Bit16	Bit15 ~ Bit0
Check Sum	Encoder pulse within one turn 0 ~ 4194304 (22bit Encoder)	Encoder turn -32768 ~ +32767	PA30 Encoder status

Explanation :

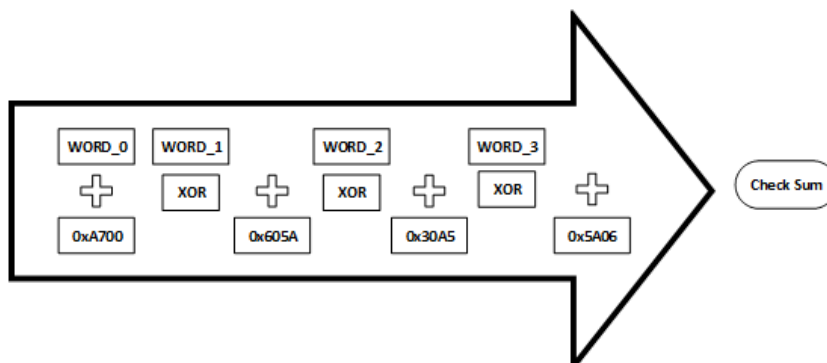

Check Sum = ((((((WORD_0+0xA700) xor WORD_1)+0x605A) xor WORD_2)+0x30A5) xor WORD_3)+0x5A06

Note :

- (1) This algorithm has no plus or minus sign.
- (2) 0xA700, 0x605A, 0x30A5, 0x5A06 are the constants of hexadecimal.
- (3) WORD_0 : encoder status (Bit15 ~ Bit0)
WORD_1 : encoder turn (Bit31 ~ Bit16)
WORD_2 : encoder pulse (Bit47 ~ Bit32)
WORD_3 : encoder pulse (Bit63 ~ Bit48)

12.2.5 Absolute position data communication protocol

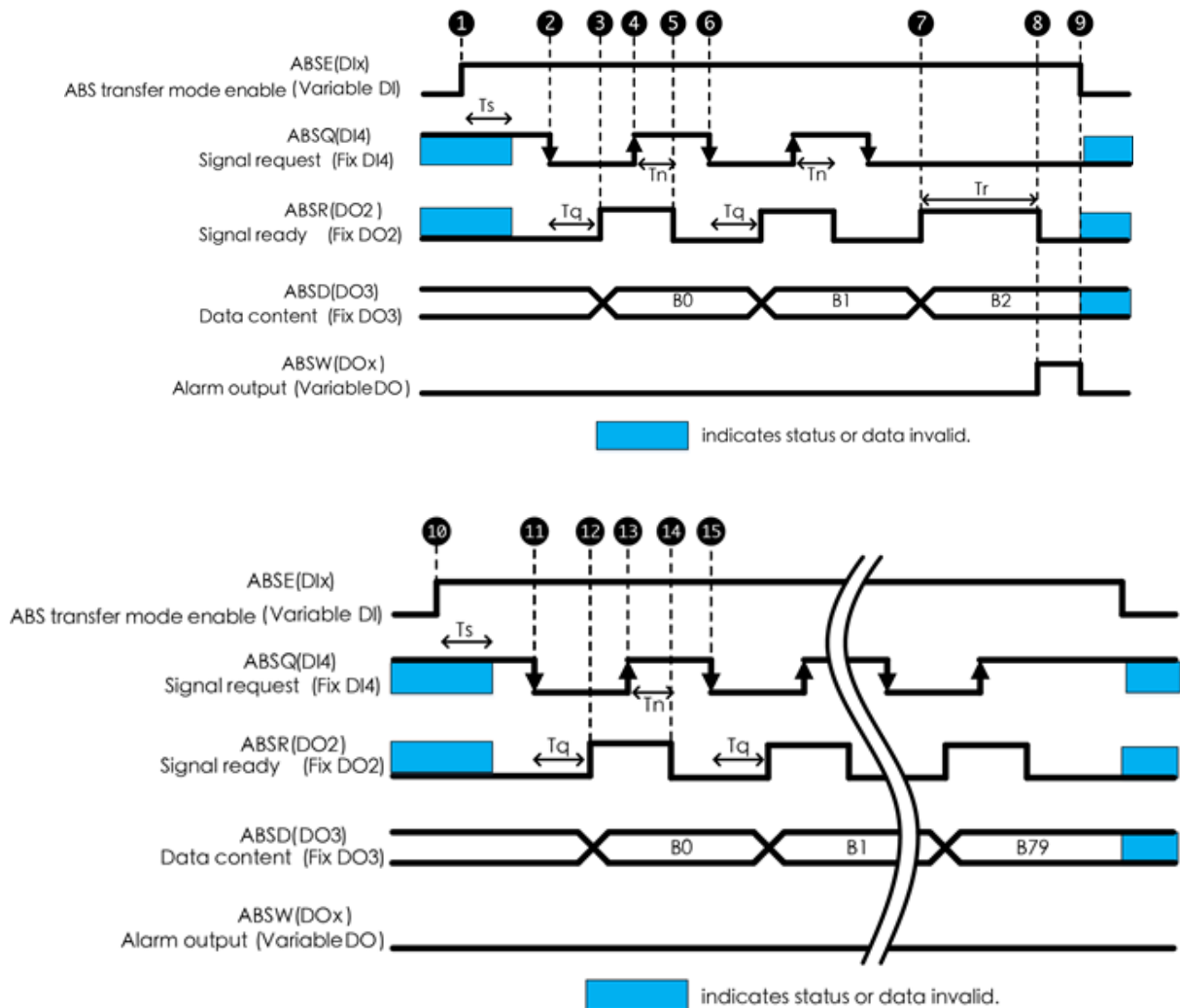

The step explanation for the communication :

1. At the very beginning of communication, the host controller must enable ABSE and all the absolute system DI/DO communication starts. A threshold time T_s for confirming the signal ABSE is necessary. After the signal has been recognized, the DI4, DO2, and DO3 (no matter what their functions are), will be switched to the function of ABSQ, ABSR, and ABSD respectively.
2. Switch ABSQ to low after it is defined, the servo drive will recognize that host controller wants to read data from drive.
3. After confirming time T_q , the data for communication is already well prepared and the signal ABSR is enabled for signaling the host controller to get data from the servo drive side.
4. When ABSR is at high level, it will read ABSQ signal. After finish reading, ABSQ will be set at high level to recognize the servo drive that the dates have been read..

5. After confirming time T_N , the servo drive will maintain ABSR to low for signaling the host controller to be ready for accessing next bit.
6. The host controller detects that ABSR is in low level will request the drive for accessing next bit.
7. The drive finished preparing data then enable ABSR.
8. After the data is ready and has been held for time T_{ry} , the servo drive still does not see the signal ABSQ controlled by the host controller, and then the servo drive will have a communication error flag ABSW raise to terminate the communication procedure.
9. The host controller detects that ABSR communication is wrong will set ABSE in low level and restart to communicate.
10. Enable ABSE again and restart communication.
11. The host controller set ABSQ in low level and request to read.
12. After confirming time T_q , the drive will inform the host controller that data could be read.
13. After the host controller detects that ABSR is high, the data is fetched. The ABSQ will be set to signal high to inform the drive after data read.
14. After confirming time T_n for ABSQ kept high, the servo drive will maintain ABSR to low for signaling the host controller to be ready for accessing next bit.
15. By repeating steps 11 to 14, to finish bit 0 to bit 79 (80 bits data) communication.

Appendix A: Accessories

Encoder connectors

Shihlin part number: SDA-ENCNL (for low inertia motor)



Shihlin part number: SDA-ENCNM (for medium inertia motor below 7kw)



Encoder cable

Shihlin part number:SDH-ENLCBL2M-L、SDH-ENLCBL5M-L、SDH-ENLCBL10M-L

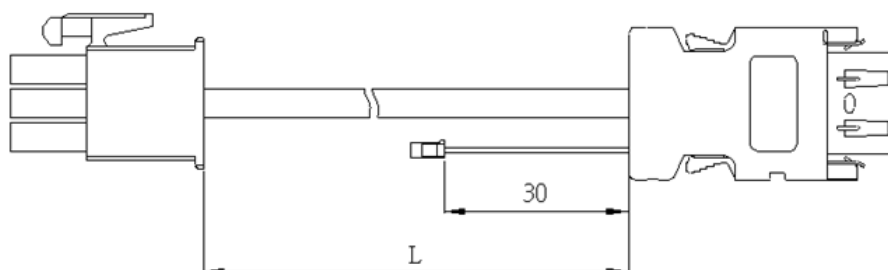

Type	Part number	Length L(mm)
low inertia encoder cable 2M	SDH-ENL-2M-L/H	2000±100
low inertia encoder cable 5M	SDH-ENL-5M-L/H	5000±100
low inertia encoder cable 10M	SDH-ENL-10M-L/H	10000±100
low inertia encoder cable 2M (Absolute type)	SDH-ENL-2M-L/H-B	2000±100
low inertia encoder cable 5M (Absolute type)	SDH-ENL-5M-L/H-B	5000±100
low inertia encoder cable 10M (Absolute type)	SDH-ENL-10M-L/H-B	10000±100

Shihlin part number: SDH-ENM-2M-L/H-B 、SDH-ENM-5M-L/H-B 、SDH-ENM-10M-L/H-B

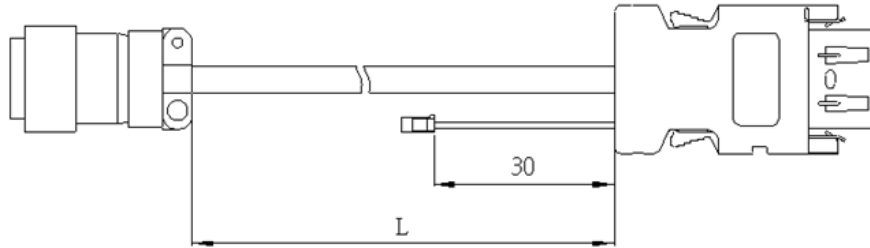

Type	Part number	Length L(mm)
medium inertia encoder cable 2M	SDH-ENM-2M-L/H	2000±100
medium inertia encoder cable 5M	SDH-ENM-5M-L/H	5000±100
medium inertia encoder cable 10M	SDH-ENM-10M-L/H	10000±100
medium inertia encoder cable 2M (Absolute type)	SDH-ENM-2M-L/H-B	2000±100
medium inertia encoder cable 5M (Absolute type)	SDH-ENM-5M-L/H-B	5000±100
medium inertia encoder cable 10M (Absolute type)	SDH-ENM-10M-L/H-B	10000±100

Power connectors

Shihlin part number:SDA-PWCNL1 (100W 、200W 、400W 、750W without electromagnetic brake)
 SDA-PWCNL2 (100W 、200W 、400W 、750W with electromagnetic brake)

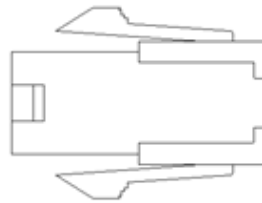

Shihlin part number:SDA-PWCNM1 (for 500W 、1KW 、1.5KW)



Shihlin part number:SDA-PWCNM2 (for 2KW 、3.5KW)

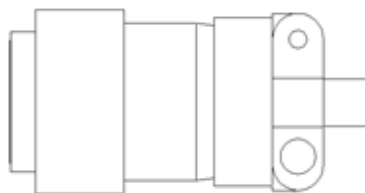

Shihlin part number:SDH-PWCNM4 (for 5KW 、7KW)

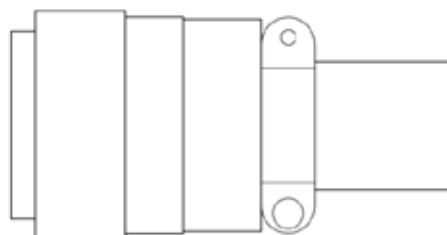

Power connectors with brake

Shihlin part number:SDH-BKCNS1 (for 5KW、7KW)

**Power line for Low inertia power line**

SDA-PWCNL □ -2M-L、SDA-PWCNL □ -5M-L、SDA-PWCNL □ -10M-L

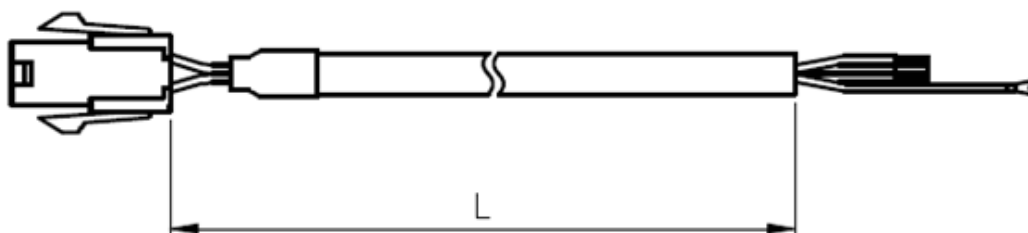

Type	Part number	Length L(mm)
Low inertia power line1 (without electromagnetic brake)	SDA-PWCNL1-2M-L	2000±100
Low inertia power line2 (without electromagnetic brake)	SDA-PWCNL1-5M-L	5000±100
Low inertia power line3 (without electromagnetic brake)	SDA-PWCNL1-10M-L	10000±100
Low inertia power line1 (with electromagnetic brake)	SDA-PWCNL2-2M-L	2000±100
Low inertia power line2 (with electromagnetic brake)	SDA-PWCNL2-5M-L	5000±100
Low inertia power line3 (with electromagnetic brake)	SDA-PWCNL2-10M-L	10000±100

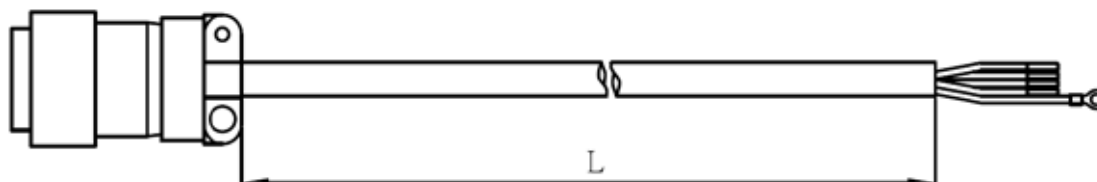
Power line for Middle inertia power line(for 500W、1KW、1.5KW)

Type	Part number	Length L(mm)
Middle inertia power line1 (without electromagnetic brake)	SDA-PWCNM1-2M-L	2000±100
Middle inertia power line2 (without electromagnetic brake)	SDA-PWCNM1-5M-L	5000±100
Middle inertia power line3 (without electromagnetic brake)	SDA-PWCNM1-10M-L	10000±100
Middle inertia power line1 (with electromagnetic brake)	SDA-PWCNM1B-2M-L	2000±100
Middle inertia power line2 (with electromagnetic brake)	SDA-PWCNM1B-5M-L	5000±100
Middle inertia power line3 (with electromagnetic brake)	SDA-PWCNM1B-10M-L	10000±100

Power line for Middle inertia power line(for 2KW ~ 3.5KW)

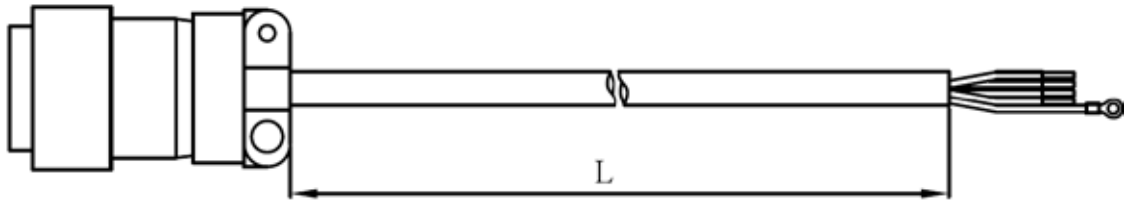

Type	Part number	Length L(mm)
Middle inertia power line1 (without electromagnetic brake)	SDA-PWCNM2-2M-L	2000±100
Middle inertia power line2 (without electromagnetic brake)	SDA-PWCNM2-5M-L	5000±100
Middle inertia power line3 (without electromagnetic brake)	SDA-PWCNM2-10M-L	10000±100
Middle inertia power line1 (with electromagnetic brake)	SDA-PWCNM2B-2M-L	2000±100
Middle inertia power line2 (with electromagnetic brake)	SDA-PWCNM2B-5M-L	5000±100
Middle inertia power line3 (with electromagnetic brake)	SDA-PWCNM2B-10M-L	10000±100

Power line for Middle inertia power line(for 5KW)

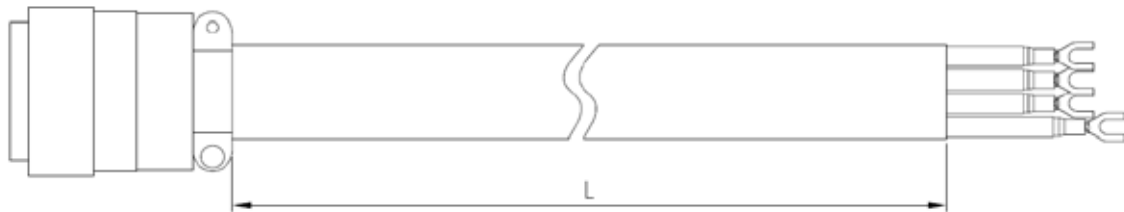

Type	Part number	Length L(mm)
Middle inertia power line1 (without electromagnetic brake)	SDH-PWCNM4-2M-L	2000±100
Middle inertia power line2 (without electromagnetic brake)	SDH-PWCNM4-5M-L	5000±100
Middle inertia power line3 (without electromagnetic brake)	SDH-PWCNM4-10M-L	10000±100

Power line for Middle inertia power line(for 7KW)

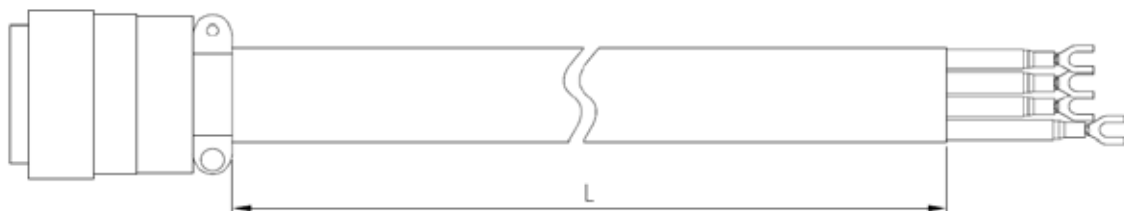

Type	Part number	Length L(mm)
Middle inertia power line1 (without electromagnetic brake)	SDH-PWCNM5-2M-L	2000±100
Middle inertia power line2 (without electromagnetic brake)	SDH-PWCNM5-5M-L	5000±100
Middle inertia power line3 (without electromagnetic brake)	SDH-PWCNM5-10M-L	10000±100

Power line for Middle inertia power line(for 5KW · 7KW without electromagnetic brake)



Type	Part number	Length L(mm)
5K/7K Middle inertia power line1 (without electromagnetic brake)	SDH-BKCNS1-2M-L	2000±100
5K/7K Middle inertia power line2 (without electromagnetic brake)	SDH-BKCNS1-5M-L	5000±100
5K/7K Middle inertia power line3 (without electromagnetic brake)	SDH-BKCNS1-10M-L	10000±100

RS232/RS485 communication cable between drive and computer

Shihlin part number:SDA-RJ45-3M



Type	Part number	Length L(mm)
RS232/RS485 communication cable	SDA-RJ45-3M	3000±10

USB communication cable

Shihlin part number: SDA-USB3M

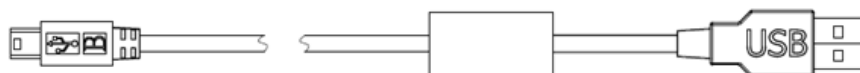

CN1 I/O connector

Shihlin part number: SDA-CN1

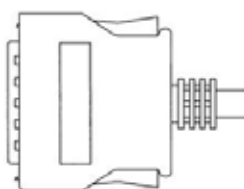

CN1 I/O control cable

Shihlin part number: SDA-TBL05M、SDA-TBL1M、SDA-TBL2M

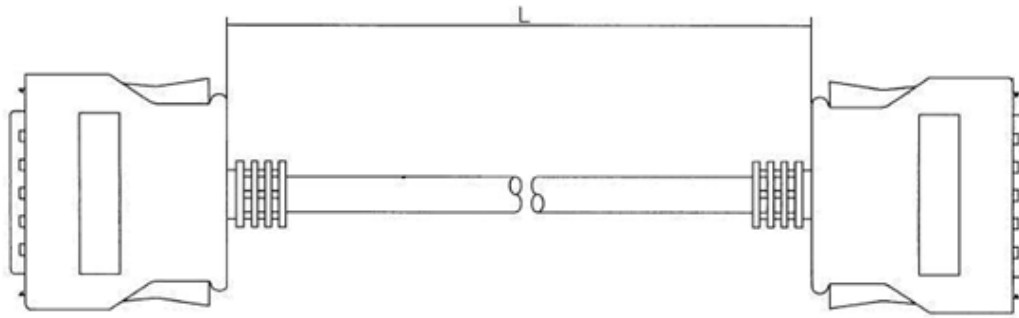



Type	Part number	Length L(mm)
CN1 I/O control cable 1	SDA-TBL05M	500±10
CN1 I/O control cable 2	SDA-TBL1M	1000±10
CN1 I/O control cable 3	SDA-TBL2M	2000±10

CN1 I/O terminal block

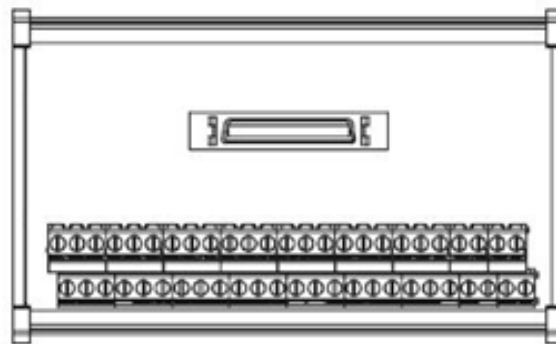
Shihlin part number: SDA-TBL50



Absolute encoder accessories

Absolute encoder battery set	Absolute encoder battery
Shihlin part number : SDH-BAT-SET	Shihlin part number : SDH-BAT
	

Brake resistor:

Drive type	Built-in resistor		External resistor (suggestion)		Brake resistor part No.
	Resistance (Ω)	Capacity (W)	Permissible Min resistance(Ω)	Capacity (W)	
SDH-010A2	100	20	100	500	ABR-500W100
SDH-020A2	100	20	100	500	ABR-500W100
SDH-040A2	100	20	100	500	ABR-500W100
SDH-050A2	100	20	100	500	ABR-500W100
SDH-075A2	40	40	40	1000	ABR-1000W40
SDH-100A2	40	40	40	1000	ABR-1000W40
SDH-150A2	13	100	13	1000	ABR-1000W13
SDH-200A2	13	100	13	1000	ABR-1000W13
SDH-350A2	13	100	13	1000	ABR-1000W13
SDH-500A2	Withour built-in resistor		8	1000	ABR-1000W8
SDH-700A2			8	1000	ABR-1000W8

★ To confirm that P and D terminal are in open-circuit status and that P and C terminal are connected with the external brake resistor.

Appendix B: Parameters communication address

NO	Address	NO	Address	NO	Address
PA01	0x0300	PA18	0x0322	PA35	0x0344
PA02	0x0302	PA19	0x0324	PA36	0x0346
PA03	0x0304	PA20	0x0326	PA37	0x0348
PA04	0x0306	PA21	0x0328	PA38	0x034A
PA05	0x0308	PA22	0x032A	PA39	0x034C
PA06	0x030A	PA23	0x032C	PA40	0x034E
PA07	0x030C	PA24	0x032E	PA41	0x0350
PA08	0x030E	PA25	0x0330	PA42	0x0352
PA09	0x0310	PA26	0x0332	PA43	0x0354
PA10	0x0312	PA27	0x0334	PA44	0x0356
PA11	0x0314	PA28	0x0336	PA45	0x0358
PA12	0x0316	PA29	0x0338	PA46	0x035A
PA13	0x0318	PA30	0x033A	PA47	0x035C
PA14	0x031A	PA31	0x033C	PA48	0x035E
PA15	0x031C	PA32	0x033E	PA49	0x0360
PA16	0x031E	PA33	0x0340	PA50	0x0362
PA17	0x0320	PA34	0x0342		
PB01	0x0400	PB18	0x0422	PB35	0x0444
PB02	0x0402	PB19	0x0424	PB36	0x0446
PB03	0x0404	PB20	0x0426	PB37	0x0448
PB04	0x0406	PB21	0x0428	PB38	0x044A
PB05	0x0408	PB22	0x042A	PB39	0x044C
PB06	0x040A	PB23	0x042C	PB40	0x044E
PB07	0x040C	PB24	0x042E	PB41	0x0450
PB08	0x040E	PB25	0x0430	PB42	0x0452
PB09	0x0410	PB26	0x0432	PB43	0x0454
PB10	0x0412	PB27	0x0434	PB44	0x0456
PB11	0x0414	PB28	0x0436	PB45	0x0458
PB12	0x0416	PB29	0x0438	PB46	0x045A
PB13	0x0418	PB30	0x043A	PB47	0x045C
PB14	0x041A	PB31	0x043C	PB48	0x045E
PB15	0x041C	PB32	0x043E	PB49	0x0460
PB16	0x041E	PB33	0x0440	PB50	0x0462
PB17	0x0420	PB34	0x0442		
NO	Address	NO	Address	NO	Address
PC01	0x0500	PC21	0x0528	PC41	0x0550
PC02	0x0502	PC22	0x052A	PC42	0x0552
PC03	0x0504	PC23	0x052C	PC43	0x0554
PC04	0x0506	PC24	0x052E	PC44	0x0556
PC05	0x0508	PC25	0x0530	PC45	0x0558
PC06	0x050A	PC26	0x0532	PC46	0x055A
PC07	0x050C	PC27	0x0534	PC47	0x055C
PC08	0x050E	PC28	0x0536	PC48	0x055E
PC09	0x0510	PC29	0x0538	PC49	0x0560
PC10	0x0512	PC30	0x053A	PC50	0x0562
PC11	0x0514	PC31	0x053C	PC51	0x0564
PC12	0x0516	PC32	0x053E	PC52	0x0566
PC13	0x0518	PC33	0x0540	PC53	0x0568
PC14	0x051A	PC34	0x0542	PC54	0x056A
PC15	0x051C	PC35	0x0544	PC55	0x056C
PC16	0x051E	PC36	0x0546	PC56	0x056E
PC17	0x0520	PC37	0x0548	PC57	0x0570
PC18	0x0522	PC38	0x054A	PC58	0x0572
PC19	0x0524	PC39	0x054C	PC59	0x0574
PC20	0x0526	PC40	0x054E	PC60	0x0576
PD01	0x0600	PD15	0x061C	PD29	0x0638
PD02	0x0602	PD16	0x061E	PD30	0x063A
PD03	0x0604	PD17	0x0620	PD31	0x063C

PD04	0x0606	PD18	0x0622	PD32	0x063E
PD05	0x0608	PD19	0x0624	PD33	0x0640
PD06	0x060A	PD20	0x0626	PD34	0x0642
PD07	0x060C	PD21	0x0628	PD35	0x0644
PD08	0x060E	PD22	0x062A	PD36	0x0646
PD09	0x0610	PD23	0x062C	PD37	0x0648
PD10	0x0612	PD24	0x062E	PD38	0x064A
PD11	0x0614	PD25	0x0630	PD39	0x064C
PD12	0x0616	PD26	0x0632	PD40	0x064E
PD13	0x0618	PD27	0x0634		
PD14	0x061A	PD28	0x0636		

NO	Address	NO	Address	NO	Address
PE01	0x0700	PE34	0x0742	PE67	0x0784
PE02	0x0702	PE35	0x0744	PE68	0x0786
PE03	0x0704	PE36	0x0746	PE69	0x0788
PE04	0x0706	PE37	0x0748	PE70	0x078A
PE05	0x0708	PE38	0x074A	PE71	0x078C
PE06	0x070A	PE39	0x074C	PE72	0x078E
PE07	0x070C	PE40	0x074E	PE73	0x0790
PE08	0x070E	PE41	0x0750	PE74	0x0792
PE09	0x0710	PE42	0x0752	PE75	0x0794
PE10	0x0712	PE43	0x0754	PE76	0x0796
PE11	0x0714	PE44	0x0756	PE77	0x0798
PE12	0x0716	PE45	0x0758	PE78	0x079A
PE13	0x0718	PE46	0x075A	PE79	0x079C
PE14	0x071A	PE47	0x075C	PE80	0x079E
PE15	0x071C	PE48	0x075E	PE81	0x07A0
PE16	0x071E	PE49	0x0760	PE82	0x07A2
PE17	0x0720	PE50	0x0762	PE83	0x07A4
PE18	0x0722	PE51	0x0764	PE84	0x07A6
PE19	0x0724	PE52	0x0766	PE85	0x07A8
PE20	0x0726	PE53	0x0768	PE86	0x07AA
PE21	0x0728	PE54	0x076A	PE87	0x07AC
PE22	0x072A	PE55	0x076C	PE88	0x07AE
PE23	0x072C	PE56	0x076E	PE89	0x07B0
PE24	0x072E	PE57	0x0770	PE90	0x07B2
PE25	0x0730	PE58	0x0772	PE91	0x07B4
PE26	0x0732	PE59	0x0774	PE92	0x07B6
PE27	0x0734	PE60	0x0776	PE93	0x07B8
PE28	0x0736	PE61	0x0778	PE94	0x07BA
PE29	0x0738	PE62	0x077A	PE95	0x07BC
PE30	0x073A	PE63	0x077C	PE96	0x07BE
PE31	0x073C	PE64	0x077E	PE97	0x07C0
PE32	0x073E	PE65	0x0780	PE98	0x07C2
PE33	0x0740	PE66	0x0782	PE99	0x07C4

NO	Address	NO	Address	NO	Address
PF01	0x0800	PF34	0x0842	PF67	0x0884
PF02	0x0802	PF35	0x0844	PF68	0x0886
PF03	0x0804	PF36	0x0846	PF69	0x0888
PF04	0x0806	PF37	0x0848	PF70	0x088A
PF05	0x0808	PF38	0x084A	PF71	0x088C
PF06	0x080A	PF39	0x084C	PF72	0x088E
PF07	0x080C	PF40	0x084E	PF73	0x0890
PF08	0x080E	PF41	0x0850	PF74	0x0892
PF09	0x0810	PF42	0x0852	PF75	0x0894
PF10	0x0812	PF43	0x0854	PF76	0x0896
PF11	0x0814	PF44	0x0856	PF77	0x0898
PF12	0x0816	PF45	0x0858	PF78	0x089A
PF13	0x0818	PF46	0x085A	PF79	0x089C

PF14	0x081A	PF47	0x085C	PF80	0x089E
PF15	0x081C	PF48	0x085E	PF81	0x08A0
PF16	0x081E	PF49	0x0860	PF82	0x08A2
PF17	0x0820	PF50	0x0862	PF83	0x08A4
PF18	0x0822	PF51	0x0864	PF84	0x08A6
PF19	0x0824	PF52	0x0866	PF85	0x08A8
PF20	0x0826	PF53	0x0868	PF86	0x08AA
PF21	0x0828	PF54	0x086A	PF87	0x08AC
PF22	0x082A	PF55	0x086C	PF88	0x08AE
PF23	0x082C	PF56	0x086E	PF89	0x08B0
PF24	0x082E	PF57	0x0870	PF90	0x08B2
PF25	0x0830	PF58	0x0872	PF91	0x08B4
PF26	0x0832	PF59	0x0874	PF92	0x08B6
PF27	0x0834	PF60	0x0876	PF93	0x08B8
PF28	0x0836	PF61	0x0878	PF94	0x08BA
PF29	0x0838	PF62	0x087A	PF95	0x08BC
PF30	0x083A	PF63	0x087C	PF96	0x08BE
PF31	0x083C	PF64	0x087E	PF97	0x08C0
PF32	0x083E	PF65	0x0880	PF98	0x08C2
PF33	0x0840	PF66	0x0882	PF99	0x08C4

Appendix C: Version information

Version: V1.00

Issue date: Oct. 2015